



IL715
SECTION E
Rev. 17 - 05/2011

Tek-CARE[®] NC300[™] II
Microprocessor
Nurse Call System

UL[®] 1069 Listed

Operation, Installation and Service Manual

Operating Software: TekNIOS[™] II

www.tektone.com

Phone: (828) 524-9967
Toll-Free: (800) 327-8466
Tech Support: Option 2
Sales: Option 3

277 Industrial Park Road
Franklin, NC 28734
tektone@tektone.net
Fax: (828) 524-9968

The Tek-CARE[®] NC300[™] II Series Nurse Call System is designed for hospitals, nursing homes and congregate living centers. It utilizes microprocessor based technology to provide communications between facility staff and patients, as well as an array of information system features and tools. Specific system components are supervised for reliable operation.

Tek-CARE® NC300™ II
Microprocessor Nurse Call System

Operating Software: TekNIOS™ II

The software described in this manual is furnished under a license agreement and may be used only in accordance with the terms of the agreement.

Operation, Installation and Service Manual

Copyright © 2001–2011 TekTone® Sound & Signal Mfg., Inc., All rights reserved.

No part of this publication may be copied without the express written permission of TekTone® Sound & Signal Mfg., Inc. The content of this manual is furnished for informational use only, is subject to change without notice, and should not be construed as a commitment by TekTone® Sound & Signal Mfg., Inc. TekTone® Sound & Signal Mfg., Inc. assumes no responsibility or liability for any errors or inaccuracies that may appear in this documentation.

TekTone, the TekTone logo, Tek-Call, Tek-Care, Tek-Check-In, Tek-Com, Tek-Digicare, Tek-Door, Tek-Entry III, Tek-Guard, Tek-Micro, Tek-Micro II, Tek-MMARS II, TekNIOS, TekNIOS II, Tek-Paging, Tek-Phone, Tek-Safe, Tek-Select II, Tek-Sentry, Tek-Sound, Tek-Status, Tek-Trio and Tek-View are either registered trademarks or trademarks of TekTone® Sound & Signal Mfg., Inc. in the United States and/or other countries. All other trademarks are the property of their respective owners.

TekTone® Sound & Signal Mfg., Inc., 277 Industrial Park Road, Franklin, North Carolina 28734, USA.

Table of Contents

System Introduction x

A Word about ESD (Electrostatic Discharge) xi

Part 1 — System Operation, Configuration and Programming

System Operating Instructions 1

- NC304 Master Station Controls and Indicators 1
- NC304 Master Station Connections 2
- NC306 Master Station Controls and Indicators 3
- NC306 Master Station Connections 5
- NC313 VGA Monitor Controls and Indicators 5
- NC315 LCD VGA Monitor Controls and Indicators 8
- NC304, NC304LCD Master Operation 9
 - Answer a Call Automatically 9
 - Answer a Call Selectively 9
 - Place a Call 9
 - Place a Call to Another Master Station 10
 - Receive a Call from Another Master Station 10
 - Request or Cancel Nurse/Aide Service 10
 - Request or Cancel Stat Service 10
 - Page a Zone 10
 - Page All Assigned Zones 11
 - Page Nurse/Aide by Presence Registration 11
 - Page All Stations on the System 11
 - Use Room Monitoring 11
 - Use Nurse/Aide Follower 12
 - Taking the Master Station Offline 12
 - Bringing the Master Station Online 13
 - Radio Paging Operation 13
 - Event Printing 13
 - View Station Information 13
- NC306 Master Operation 13
 - Answer a Call Automatically 14
 - Answer a Call Selectively 14
 - Place a Call 14
 - Place a Call to Another Master Station 14
 - Receive a Call from Another Master Station 14
 - Request or Cancel Staff Service 15
 - Display Staff Presence and Service Requests 15
 - Request or Cancel Stat Service 15
 - Page a Zone 15
 - Page All Assigned Zones; Page All Zones 15
 - Page Staff by Presence Registration 15
 - Use Staff Follower 15
 - Taking the Master Station Offline 16
 - Bringing the Master Station Online 16
 - Radio Paging Operation 16
 - Event Printing 16
- IR301-series, IR302-series, IR311-series, IR312-series, IR318-series, IR319-series,
IR320-series, SF380-series Patient Station Operation 17
- IR310-series Staff and IR315-series Duty Station Operation 21
- SF337C Water Resistant Pull/Pull Cord Bath Station Operation 22
- SF340B and SF381 Pull/Pull Cord Bath Station Operation 22

Table of Contents

SF341B and SF382 Code Call Station Operation	22
SF350B Nurse/Aide Presence Station Operation	23
SF250 Staff Presence Station Operation	23
LI380, LI384A, LI386-series Dome/Zone Light Operation	24
System Configuration and Programming	25
Configuration and Programming using NC304, NC304LCD Master Stations	25
Main Menu	26
1 View System Settings	26
2 Reconfiguration	26
3 System Functions	26
4 System Diagnostics	26
5 Execute a Custom Page	26
6 Enable PS/2 Keyboard	26
7 Initiate Locator Link	26
8 Master Instant Messaging	26
9 Master Call Transfer	26
0 MSTR/TI Fault Tone Off	26
View Menus	27
1 View Remote Stations	27
2 View Master Station	27
3 View a Zone	27
Reconfiguration	27
1 Program Master	27
2 Program Station	27
3 Transmit Database	27
4 Program Pager/Print	27
5 Set Password Levels	27
6 Set Username/Password	27
7 Enable Bedout Call	27
8 Alternate Dialing	27
9 Program Roving Phone	28
System Functions	28
1 Set Time & Date	28
2 Enter Timeout for Overtimes	28
3 Monitoring	28
4 Toggle 12/24 Hour Time	28
5 Reboot Entire System	28
6 Restore Local Database	28
7 Detect System Stations	28
8 Restore System Defaults	28
Diagnostics Menu	29
1 View System Masters	29
2 View Station Poll Cycle	29
3 About Software Versions	29
5 Check Dialing Method	29
Master Programming	29
1 Set Master ID	29
2 Key Press Tones On/Off	29
3 Toggle Pre-Announce Tones	29
4 Assign Master Zones	29
5 Assign Call Responses	29
6 Offline Data to Central	29

Table of Contents

Station Programming	29
1 Program Room ID	29
2 Station On/Offline	30
3 Station Privacy On/Off	30
4 Station Paging On/Off	30
5 Program Custom Label 1	30
6 Program Custom Label 2	30
7 Program Station Zones	30
8 Station Priority	30
9 Duty Station Call Response	30
Pager Menu	30
1 Pager Zone/Call Settings	30
2 Assign Pagers to Rooms	30
3 Local Printing Only	30
4 Local Paging Only	30
5 Central Paging/Local Prn	30
6 Transmit Resets to Pagers	31
7 Enable Extended Printing	31
Dialing Methods	31
1 Normal Dialing	31
2 3-Digit Dialing	31
3 4-Digit Dialing	31
Keyboard Functions	32
NC304 series & NC351(A) series Software Component Upgrades	33
Station Database Functions	34
1 Global Status Change	37
2 Global Privacy Change	37
3 Global Paging Change	37
4 Global Zoning Change	37
5 Global Response Change	37
6 Global Priority Change	37
7 Global Dome Commands	38
8 Global Call Declaration	38
9 Global Message Assgmnts	39
Configuration and Programming using NC306 Master Stations	40
Station Privacy	40
Show a Remote Station's Privacy	40
Set a Remote Station's Privacy On/Off	40
Show All Remote Stations with Privacy On	40
Station Paging On/Off	40
Station Priority	40
Show a Remote Station's Priority	40
Change a Remote Station's Priority	40
Show All Personal Attention and Priority Remote Stations	40
Program Station Zones	40
Show a Remote Station's Zones	40
Set a Remote Station's Zones	41
Station On/Offline	41
Assign Master Zones	41
Master Station Key-Press Tones On/Off	41
Toggle Pre-Announce Tones	41
Master Station Guidance LEDs On/Off	41

Table of Contents

System Radio Paging Mode	42
Set System Time & Date	42
Reboot Entire System	42
Restore Local Database	42
Detect System Stations	42
Restore System Defaults	42
Programming Pagers and Remote Stations with the NC306 Master Station	43
Radio Pager Programming	43
Station Programming	43
Set Point Limits	45
NC306 series Software Component Upgrades	45

Part 2 – System Installation, Maintenance and Troubleshooting

System Installation	46
Problems to Avoid	47
Equipment Descriptions, Requirements and Locations	47
NC351(A) and NC351(A)/2 Central Equipment	47
PK304 Master Station Power Supply	48
NC304, NC304LCD and NC306 Master Station	48
NC315 LCD/NC313 VGA Monitor	48
IR3xx-series Stations—General Information	48
IR300-series Multipurpose Station	49
IR019C Remote Speaker/Microphone Station	49
IR301-series Single, IR302-series Dual Patient Stations	49
SF380-series Single Patient Station	49
IR311-series Single, IR312-series Dual Patient Stations	49
IR319-series Single, IR320-series Dual Patient Stations	50
PM311C/PM312C Pillow Speaker Intercom Modules	50
PM321B/PM322B Light Control Modules	50
RY350B Multi-Channel Relay	50
RY351B Hill-Rom® SideCom® Adapter	50
IR310-series Staff Station	51
IR315-series Duty Station	51
Call Cords	51
LI380 Dome Light	52
LI384A Supervised Dome Light	52
LI386-series Dome/Zone Light	52
SF Series Peripheral Devices—General Information	52
SF337C Water Resistant Bath Station	52
SF340B Bath Station	53
SF381 Standalone Bath Station	53
SF341B Supervised Code Call Station	53
SF382 Standalone Code Call Station	53
SF350B Nurse/Aide Presence Station	53
SF250 Staff Presence Station	53
Wiring Installation	54
Equipment Configuration and Settings	55
NC304 and NC304LCD Master Station	55
NC306 Master Station	56
NC351(A) or NC351(A)/2 Central Equipment	56
IR3xx-series Stations	57
IR315-series Duty Station	57

Table of Contents

SF380A Single Patient Station	58
SF380C Single Patient Station	58
SF380P Single Patient Station	58
SF381 Standalone Bath Station/SF382 Standalone Code Station	58
PM352 Station Port Card	58
PM353 Processor Card	58
PM354 Master Port Card	58
System Test Instructions	59
System Maintenance Instructions	60
NC304, NC304LCD or NC306 Master Station	60
NC351(A) or NC351(A)/2	60
IR301-series, IR302-series, IR319-series, IR320-series or SF380-series Patient Station	60
IR311-series or IR312-series Patient Station	60
LI380, LI384A and LI386-series Dome/Zone Lights	61
PK305/A Supplemental Power Supply Upgrade	61
PM352 Station Port Card Upgrade	61
PM354 Master Port Card Upgrade	61
Replacement Part Numbers	62
Upgrade Part Numbers	62
System Troubleshooting Guide	63
General Troubleshooting Techniques	63
System Event Logging	63
Voltage Readings	64
Master Station Connections	64
Patient Station Connections	65
Standalone Bath and Code Station Connections	67
Symptoms and Suggestions	67
Code Fault Indication (SF341B)	67
Comm. Fault Indication (patient station fault)	67
Data or Polling Noise	67
IR019C has no audio communications	67
IR3xx-series Patient Station is not placing calls	67
IR3xx-series Patient Station has a constant “Cord Out” message	67
IR3xx-series Patient Station that has been installed is not recognized by the system	68
IR310-series Staff Station is placing “Routine Calls”	68
IR315-series Duty Station or LI386/A/B/C Dome/Zone Lamp is not annunciating calls	68
POLLING PROCESSOR FAIL indication	68
Lamp Fault Indication	68
LI380-series Lamp is not lighting	68
MASTER FAILURE(S) indication	68
NC304, NC304LCD or NC306 Master Station has no audio communications to all patient stations	69
NC304 or NC304 LCD Master Station is making a squealing noise and has erratic LED activity	69
NC304, NC304LCD or NC306 Master Station is not displaying calls or is not handling calls as intended	69
NC304LCD or NC313 Monitor is displaying incorrect call data	69

Table of Contents

NC306 Talk LED continues to flash after CE has booted (CE LED flashing)	69
NC315/NC313 Monitor is not displaying VGA signal	69
NC315/NC313 Monitor power indicator is amber	69
NC351(A) or NC351(A)/2 Central Equipment makes a loud buzzing noise shortly after power up (internal relay is chattering)	69
Pillow Speaker Intercom is not working and audio is coming from the patient station	70
CENTRAL PROCESSOR FAIL indication at a single master location	70
SF337C or SF340B Bath Stations not placing calls	70
SF341B Code Station is not placing calls	70
SF381 Standalone Bath Station or SF382 Standalone Code Station is not placing calls	70
SF350B Nurse/Aide Presence Station is not registering or is not working correctly	71
SF250 Staff Presence Station is not registering or is not working correctly	71
Event Printing (Sample)	72
Menu Map (Figure 17)	73
System Programming Sheets (Port 1 through Port 8)	74

Illustrations & Wiring Diagrams

Figure 1 — NC304LCD Master Station	1
Figure 2 — NC304 Master Station (rear view of cabinet)	2
Figure 2a — NC306 Master Station	3
Figure 2b — NC306 Master Station (rear view of cabinet)	5
Figure 3 — NC313 VGA Monitor	5
Figure 3a — NC315 LCD VGA Monitor	8
Figure 4 — IR301-series Single Patient Station	17
Figure 5 — IR302-series Dual Patient Station	17
Figure 6 — IR311-series Single Patient Station	17
Figure 7 — IR312-series Dual Patient Station	18
Figure 8 — IR318-series Single Patient Station	18
Figure 8a — SF380-series Single Patient Station	18
Figure 8b — IR319-series Single Patient Station	18
Figure 8c — IR320-series Dual Patient Station	19
Figure 9 — SF301 and SF302 Call Cords	20
Figure 10 — SF311 and SF312 Call Cords	20
Figure 10a — SF401 Call Cord	20
Figure 11 — SF301P/SF401P, SF301PI2L/SF401P2L, SF301DIG/SF401DIG, SF41ZDL and SF41ZKAL Pillow Speakers	20
Figure 12 — IR310-series Staff Station	21
Figure 13 — IR315-series Duty Station	22
Figure 14 — SF337C Water Resistant Pull/Pull Cord Bath Station	22
Figure 15 — SF341B and SF382 Code Call Station	23
Figure 16 — SF350B Nurse/Aide Presence Station	23
Figure 16a — SF250 Staff Presence Station	24
Figure 17 — Menu Map	25, 73
Figure 18 — Offline Programming Map Reference	36
Figure 19 — Mounting IR Series Stations	49
Figure 20 — Mounting LI380, LI384A, LI386-series Dome/Zone Lights	51

Table of Contents

Figure 21	— Mounting SF Series Stations	52
Figure 22	— NC304 and NC304LCD Potentiometers Functions	55
Figure 22a	— NC306 Dipswitches and Jumper Settings	56
Figure 22b	— NC306 Potentiometer Functions	56
Figure 23	— IR3xx-series Stations Dipswitch Location and Switch Values	57
Figure 24	— IR315-series Duty Station Layout	57
Figure 25	— Tek-CARE® NC300™II Block Wiring Diagram	90
Figure 26	— Tek-CARE® NC300™II System Connection Diagram	91
Figure 27	— NC304/NC306 Block Wiring Diagram	92
Figure 28	— NC351(A) Wiring Diagram Using Individual Cables	93
Figure 29	— NC304, NC304LCD, NC306 Wiring to Central Equipment	94
Figure 30	— Connector Circuit Interconnections for Addressable Stations	95
Figure 31	— IR3xx-series Connections to Peripheral Devices	96
Figure 32	— IR3xx-series Connections with Supervised Dome Light	97
Figure 33	— LI386-series Dome/Zone Light Wiring Diagram	98
Figure 34	— RY351B Wiring Diagram	99
Figure 35	— RY350B Wiring Diagram	100
Figure 36	— PM321B/PM322B Lamp Module Wiring Diagram	101
Figure 37	— LI384A Multiple Stations	102
Figure 38	— 6 & 7-PIN Connector Outputs for IR3xx-series Stations	103
Figure 39	— NC351(A) Serial Connection Diagram	104
Figure 40	— NC351/2 Internal Hardware Diagram	105
Figure 40a	— NC351(A)/2 Internal Hardware Diagram	106
Figure 41	— NC351(A)/2 Expanded System Exploded Internal Wiring Diagram	107
Figure 42	— PM352 and PM354 Jumper Settings	108
Figure 43	— SF380C Connections to Peripheral Devices	109
Figure 44	— SF380P Connections to Peripheral Devices	110
Figure 45	— SF381/SF382 Wiring Diagram	111
Figure 46	— Keypad for NC306	112
Figure 47	— SF380A Wiring Diagram	113
Figure 48	— LI484LED Wiring Diagram	114
Figure 49	— LI380LED Wiring Diagram	115
Figure 50	— LI386LED Wiring Diagram	116

System Introduction

www.leedan.com info@leedan.com Toll-Free: 1-800-231-1414

The Tek-CARE® NC300™ II Nurse Call System is a supervised microprocessor-based nurse call system that provides a complete range of two-way audio and visual signaling combined with programmable system configuration and information tools. These functions permit easy communication between facility staff and patients, as well as between staff members.

The master station and VGA monitor comprise the nursing control station where the patient calls are registered and displayed in order of priority and time of origin. The control station provides features to monitor staff as well as all patient call activity with an easy to use interface for programming the master, system and remote station configurations. These features will be reviewed in greater detail in the **System Operating Instructions** and **System Configuration and Programming** sections.

The system is completed by a variety of patient stations and peripheral devices to meet all staff and patient needs. The equipment uses a simplified wiring scheme and plug-in modular components, allowing them to be expanded and interchanged as needed in existing and new facilities.

A Word about ESD (Electrostatic Discharge)

What Is It? Static electricity is a result of triboelectric charging of two dissimilar nonconductive materials that are rubbed together, such as rubbing your feet on a carpet on a cold winter day or in a dry climate. The resulting charge is detected when you reach out to touch a doorknob or some other metallic object. The resulting discharge may only be startling or, in severe cases, it may even be painful. The actual electrical charge is dependant on the materials being rubbed together, humidity, the rate of separation, and other factors.

What Can It Do? While this effect may be disturbing to humans, the effect on electronic equipment is often more serious, ranging from operational disruption to actual component damage. These effects result from the high voltages that may be developed. The simple act of walking across a carpet may develop as much as 30,000 volts, and changing a bed sheet may create a charge of 100,000 volts or more. Such voltages readily cause arcing (the spark that can be observed when you grab a doorknob after walking across a carpet, etc.). The arcing is evidence of the discharge path. Due to the high voltage involved, the discharge current can jump to any nearby metallic or non-metallic object. If the discharge is to or through an electronic device, such as the nurse call system, the operation of the device may be affected. If the discharge current passes through internal components, these components may be damaged or their operation degraded.

What Can We Do About It? The manufacturer of the nurse call equipment has already taken steps to protect the equipment from electrostatic discharge (ESD) effects. However, since the cause is not in the equipment, but in the environment, further measures are required of the installer and the user to achieve complete protection.

What The Installer Can Do: In humid climates or in places where the relative humidity is kept at 65% or greater, there will likely be few problems with ESD. Where problems may occur the following measures can be taken.

- Ground all exposed metal surfaces. Grounding should be to a #16 gauge or larger conductor.
- Install nurse call system wiring in metal conduit. This conduit may be used to ground panels.
- Use shielded cable for nurse call system station-to-station wiring. The use of open conductors invites inductive coupling of discharge currents, which can cause the same problems as direct discharge currents.
- Ground your body before handling system components. This can be done by using a wrist strap, or simply by contacting a grounded metal surface. Use caution to avoid hazardous voltages while grounded.

What The User Can Do: The most common generation of ESD in hospitals is due to changing linen on hospital beds while the patient call cord or pillow speaker is still connected to the nurse call system. The following precautions will help.

- Remove the call cord or pillow speaker from the bed before changing the linen. It will be necessary for the nursing staff to discharge themselves by contacting a grounded metal object before placing the call cord or pillow speaker back on the bed; otherwise a spark will jump to the nurse call equipment, causing the very damage they are trying to avoid. To avoid a shock while discharging static electricity on the body, hold a metal object, such as a key, and use that object to contact the grounded surface.
- Ground the bed and use antistatic mattress covers in contact with the bed frame. For safety, it may be desirable to make the ground connection through a 1-megohm resistor. Nursing staff must be trained to disconnect and reconnect the ground whenever beds have to be moved.
- Use grounded appliances and equipment near nurse call systems. The use of approved electrical equipment will usually take care of this.

This information is provided to make you aware of ESD problems so that precautions may be taken to avoid damage and disruption of system operation.

Part 1 – System Operation, Configuration and Programming

System Operating Instructions

NC304 Master Station Controls and Indicators

This section provides complete operating instructions for all Tek-CARE® NC300™II System Equipment, as well as drawing references for use in locating and describing all controls and indicators. System operators must read the following operating instructions concerning system equipment and terms used in conjunction with the equipment.

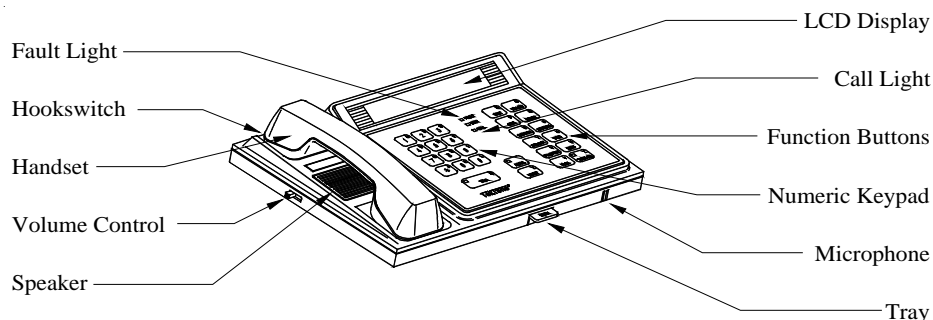

Figure 1 – NC304LCD Master Station
NC304 controls are the same, but device has no LCD display

Function Buttons: These buttons control most system functions and are described below.

TALK	(White)	Controls loudspeaker audio—press to talk and release to listen.
ALPHA	(White)	Switches to alternate key usage for alpha characters.
RESET	(Black)	Terminates most operations, and typically allows the user to exit programming without saving.
STAT	(Red)	Initiates an urgent “STAT” service request.
FOLLOW	(Orange)	Initiates Nurse Follower operations. The button’s LED will light while function is in use.
AIDE	(Yellow)	Initiates Aide service request.
NURSE	(Green)	Initiates Nurse service request.
MONITOR	(Blue)	Displays Monitor function menu for entering room numbers and initiating the Monitor function.
CAPTURE	(Blue)	Displays menu for the master’s Zone assignments (for the master on which the button is pressed).
PRIVACY	(Blue)	Changes the Privacy status of the patient station number entered.
VIEW	(Blue)	Displays the Station Information box. Enter a room number and bed ID to review the specific information about that station.
PRIORITY	(Blue)	Changes the priority status of the patient station number entered.
MENU	(Blue)	Displays system menus and functions.
PAGE	(Med. Gray)	Initiates Paging functions.
TONE ON	(Lt. Gray)	Silences the tone for Routine calls. LED indicates status.

Numeric Keypad: The keypad is used for entry of information, programming and configuration.

Part 1 – System Operation, Configuration and Programming

System Operating Instructions

Handset: The handset is used to provide private conversation when loudspeaker communication is not desired. To use, simply pick up the handset. Users may also return to master station console mode from keyboard mode by simply picking up the handset and placing it back down (actuating the hookswitch). This is particularly useful if the master station has been left in keyboard operation mode and the keyboard has been removed.

Call Light: The call light flashes slowly for low priority calls, at a medium rate for medium priority calls, and at a fast rate for high priority calls.

Fault Light: This indicator light flashes in alternation with the call light when a central equipment fault occurs.

LCD Display (NC304LCD): This display shows up to 4 calls, sorted by priority and time of origin.

Volume Control: This control adjusts the incoming voice communication level.

Speaker/Microphone: These components are used for communicating with the patient and staff stations.

Tone Signals:

Fast repeating tone—High Priority call; Master, Central or Polling Processor Fail fault (cannot be silenced or reset at master)

Slow repeating tone—Medium Priority call

Single tone every 8 seconds—Low Priority call; Lamp, Code or Comm fault (can be silenced, but cannot be reset at master)

Tray: The tray holds a Quick-Reference Card for system operations.

NC304 Master Station Connections

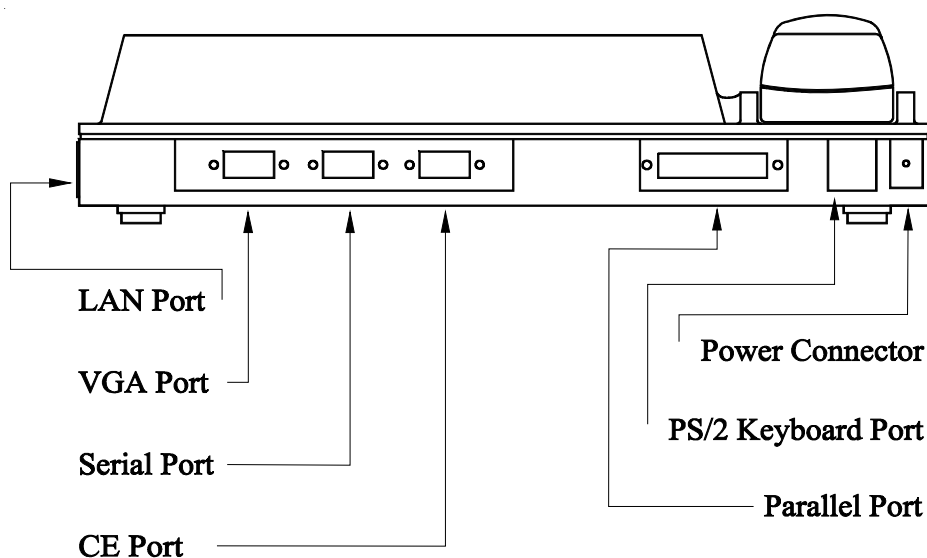

Figure 2 – NC304 Master Station
(rear view of cabinet)

Part 1 – System Operation, Configuration and Programming

System Operating Instructions

NC304 Master Station Connections

continued

LAN Port: Currently unused. Provided for future applications.

VGA Port: The NC315 LCD/NC313 VGA monitor is plugged into this port. Note: If no VGA monitor is connected to the master station, the VGA port will shut down. To reactivate it, connect a VGA monitor to the master station and reset it using the Reset button.

Serial Port: This port provides a connection point for UL® 1069 Listed serial devices, or to connect a laptop computer for software upgrades.

CE Port: This port is the connection point for the provided cable that interconnects the master station to the provided wall plate jack. The wall plate is connected to the central equipment via field wiring, as described later in this manual.

Power Connector: This connector is where the included PK304 Power Supply is connected to the master station.

PS/2 Keyboard Port: This port is used to connect a PC-type keyboard for entering system data and settings as an alternate to using the master station. See **Keyboard Functions** later in Part 1.

Parallel Port: This port provides a connection point for UL® 1069 Listed parallel devices.

Reset Switch (not shown in diagram): On the underside of the master station is an access hole with a visible microswitch inside. Momentarily pressing this microswitch will reset (soft boot) the master station.

NC306 Master Station Controls and Indicators

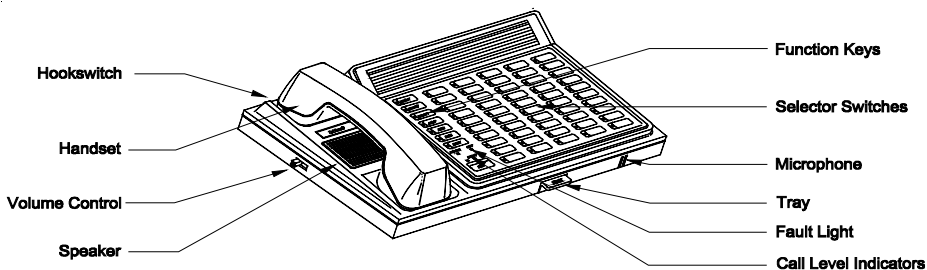

Figure 2a – NC306 Master Station

Function buttons: Most function buttons perform different tasks depending whether a selector button is pushed first. (Refer to **Figure 46, Keypad for NC306.**)

Only the function button is pushed:

TALK	(Gray)	Controls loudspeaker audio—press to talk and release to listen.
PRIVACY	(Red)	Shows which stations have privacy set.
FOLLOW	(Orange)	Initiates Nurse Follower operations.
PRIORITY	(Yellow)	Shows which stations have personal attention or priority set. Stations' selector key LEDs will flash slow or fast.
STAFF	(Green)	Shows locations of registered staff.
ZONE	(Blue)	Shows master settings for zones: Keys in the second row indicate zones A–J. Keys in the third row indicate zones K–P.

Part 1 – System Operation, Configuration and Programming

System Operating Instructions

NC306 Master Station Controls and Indicators *continued*

ZONE, 0		Key-Press Tones on/off: when lit, key-press assurance tones are on—press button to toggle.
ZONE, 1		Preannounce on/off: when lit, a one second preannounce tone is sent to a patient stations when selected—press button to toggle.
ZONE, 2		Guidance LEDs on/off: when lit, Function key LEDs light to show available options—press button to toggle.
ZONE, 3		No central radio paging.
ZONE, 4		Central paging enabled, call resets not sent to pagers.
ZONE, 5		Central paging enabled, call resets sent to pagers.
PAGE	(Violet)	Press to show pageable zones, then select a zone to page it.
RESET	(Black)	Terminates current function.

Selector button is pushed and then the function button is pushed:

TALK	(Gray)	Controls loudspeaker audio—press to talk and release to listen.
PRIVACY	(Red)	First press shows current privacy status of selected station,. Second press toggles on/off.
FOLLOW	(Orange)	Initiates Nurse Follow to the selected room.
PRIORITY	(Yellow)	First press shows current priority. Each additional press toggles through the priorities (routine, personal attention, priority).
STAFF	(Green)	Sets staff request for the selected room.
ZONE	(Blue)	Shows the zones the station is set for. Press the zone switches to change the zones to which the station is assigned. Also shows the station’s privacy, priority and zone paging on/off settings.
PAGE	(Violet)	Has no function.
RESET	(Black)	Terminates current function.

Reset LED: Flashes to indicate that RESET button must be pushed to complete an operation.

Handset: The handset is used to provide private conversation when loudspeaker communication is not desired. To use, simply pick up the handset.

Call Light: The call light flashes slowly for low priority calls, at a medium rate for medium priority calls, and at a fast rate for high priority calls.

Fault Light: This indicator lights when a fault occurs on the system.

Volume Control: This control adjusts the incoming voice communication level.

Speaker/Microphone: These components are used for communicating with the patient and staff stations.

Tone Signals:

Fast repeating tone—High Priority call; Master, Central or Polling Processor Fail fault (cannot be silenced or reset at master)

Slow repeating tone—Medium Priority call

Single tone every 8 seconds—Low Priority call; Lamp, Code or Comm fault (can be silenced, but cannot be reset at master)

Tray: The tray holds a Quick-Reference Card for system operations.

Part 1 – System Operation, Configuration and Programming

System Operating Instructions

NC306 Master Station Connections

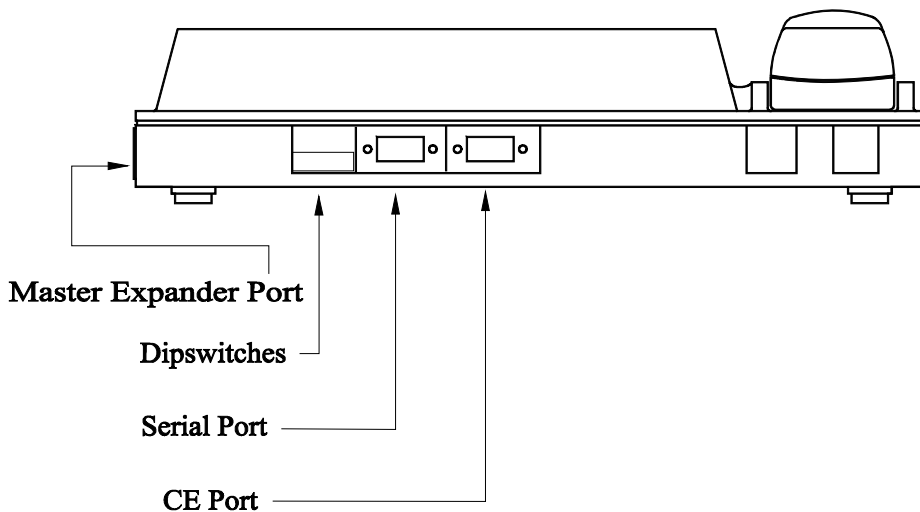

Figure 2b – NC306 Master Station
(rear view of cabinet)

Master Expander Port: This is the connection port for an NC255 Master Station Expander, to increase number of stations from 50 to 100. **A maximum of three NC306 Masters with NC255 Expanders can be connected to the NC351(A) or NC351(A)/2 Central Equipment. (Without NC255 Expanders, the maximum is four NC306 Masters.)**

Dipswitches: Refer to the NC306 Dipswitch Settings figure in the **Equipment Configuration and Settings** section of **System Installation**.

Serial Port: This port provides a connection point for UL® 1069 Listed serial devices, or to connect a laptop computer for software upgrades.

CE Port: This port is the connection point for the provided cable that interconnects the master station to the provided wall plate jack. The wall plate is connected to the central equipment via field wiring, as described later in this manual.

NC313 VGA Monitor Controls and Indicators

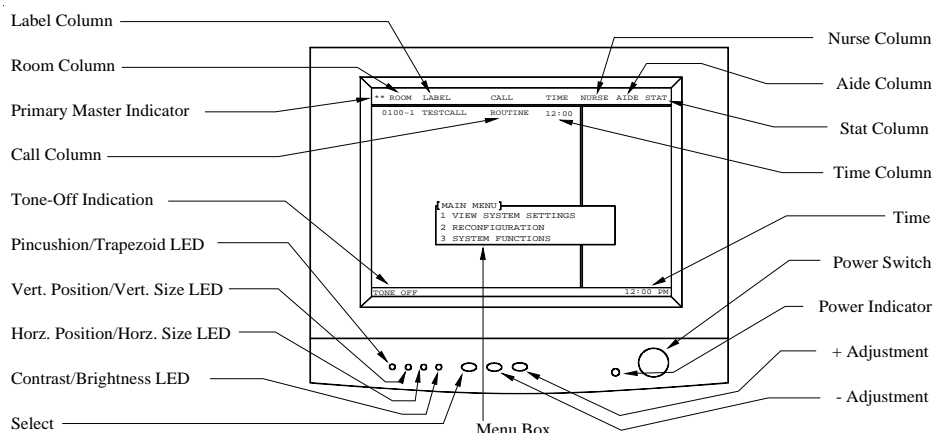

Figure 3 – NC313 VGA Monitor

Part 1 – System Operation, Configuration and Programming

System Operating Instructions

NC313 VGA Monitor Controls and Indicators *continued*

Power Switch: Press this switch to turn the monitor on, press again to turn the monitor off.

Power Indicator: When lit green, the monitor is powered on. See **Troubleshooting Guide** if the indicator is amber.

+ Adjustment: Press to increase the setting for the selected monitor adjustment parameter. This is used in conjunction with the **Select** button. If this is pressed in conjunction with the **- Adjustment** button, the monitor will be returned to default settings.

- Adjustment: Press to decrease the setting for the selected monitor adjustment parameter. This is used in conjunction with the **Select** button. If this is pressed in conjunction with the **+ Adjustment**, the monitor will be returned to default settings.

Select: Press to select the desired monitor adjustment parameter (indicated by the LED and color).

Contrast/Brightness LED: When lit green, the contrast parameter is selected. When lit amber, the brightness parameter is selected.

Horizontal Position/Horizontal Size LED: When lit green, the horizontal-position parameter is selected. When lit amber, the horizontal-size parameter is selected.

Vertical Position/Vertical Size LED: When lit green, the vertical-position parameter is selected. When lit amber, the vertical-size parameter is selected.

Pincushion/Trapezoid LED: When lit green, the pincushion parameter is selected. When lit amber, the trapezoid parameter is selected.

Primary Master Indicator: A double asterisk (**) indicates that the associated master station is the primary master station on the system, also known as master address #1. A single asterisk (*) indicates that the associated master station is not the primary master station.

Room Column: Room numbers for calls are displayed in this column.

Label Column: Labels assigned to rooms are displayed in this column when a call is placed.

Call Column: The type of call placed is displayed here.

Time Column: The time the call was placed is displayed here.

Nurse Column: Nurse presence registry and nurse requests are displayed in this column.

Aide Column: Aide presence registry and aide requests are displayed in this column.

Stat Column: Stat requests are displayed in this column.

Menu Box: These will appear when the menu button is pressed. See the **System Configuration and Programming** section for additional information.

Tone-Off Indication: When “Tone Off” is displayed, routine call tones are silenced. When “Tone On” is displayed, routine call tones will annunciate.

Time: The time the last system activity occurred is displayed here.

Part 1 – System Operation, Configuration and Programming

System Operating Instructions

NC313 VGA Monitor Controls and Indicators *continued*

Call Types and Priority Indications: Incoming calls are displayed in Standard English. They are displayed in order of origination and priority (see *Priority Listing* below). Up to 22 call events may be displayed at the same time. Additional calls are stored in memory and are indicated by a “MORE CALLS WAITING” message. A ROUTINE call will be upgraded to PERSONAL ATTENTION once the overtime limit is exceeded. If a Nurse or Aide request is allowed to exceed the overtime limit, a call will automatically be generated for the associated room.

Priority Listing

High Priority	CODE CALL FIRE * MONITOR
Medium Priority	EMERGENCY BATH PRIORITY BED OUT CORD OUT
Low Priority	PERSONAL ATTENTION DUTY STAFF ROUTINE

*** NOTE: The Tek-CARE® NC300™ II System is not tested as a fire alarm system and is not intended as a primary means of evacuation.**

System Status Indications: These indications occur to let the system users know when the Tek-CARE® NC300™ II System has detected faults. These can only be canceled by correcting the source of the fault. Reference the **Troubleshooting Guide** for suggestions to resolve these problems.

COMM. FAULT – Indicates that the system is no longer communicating with the indicated station.

LAMP FAULT – Indicates that the supervised dome or zone lamp associated with the patient station has an open lamp bulb. If this indication appears with unsupervised dome lamps, verify that the lamp fault jumper is installed (refer to **Figure 31—IR3xx-series Series Connections to Peripheral Devices**).

MASTER FAILURE(S) # – This indication appears on other master stations when a master station is no longer communicating with the central equipment. The # symbol represents the master number and master port that is experiencing a problem (1 through 8). When this event occurs, all calls on the system are displayed on all of the remaining master stations. All zone controls are overridden. To restore the system to its previous operational state, correct the master failure, and then power down the entire system and restart it.

CENTRAL PROCESSOR FAIL – This indicates that the master station is no longer communicating with the central equipment or that one of the processors in the central equipment has failed. This message may be displayed during normal start-up and reboot processes as the system begins to come online.

POLLING PROCESSOR FAIL – This indicates that one of the processors in the central equipment has failed.

Part 1 – System Operation, Configuration and Programming

System Operating Instructions

NC313 VGA Monitor Controls and Indicators *continued*

Miscellaneous Indications:

BED OUT – This is a call type that is initiated when the system incorporates RY351B Hill-Rom® Adapter Modules. It indicates that a bed has been disconnected from the associated wall plate.

NURSE FOLLOW ACTIVE – Indicates that the nurse follower feature is active.

TONE-OFF – Indicates that the routine call tones have been silenced.

TIME – Indicates the time of the last system activity.

NC315 LCD VGA Monitor Controls and Indicators

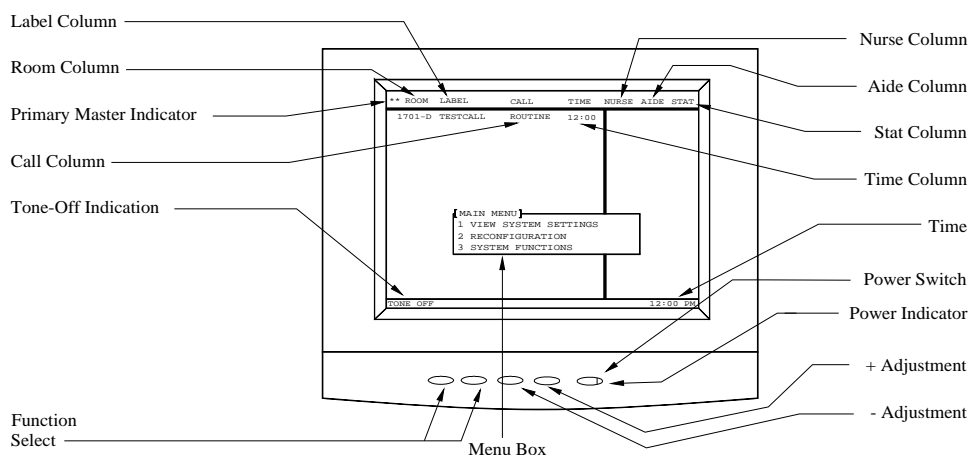

Figure 3a – NC315 LCD VGA Monitor

The NC315 LCD VGA Monitor functions in the same manner as the NC313 VGA Monitor, except that the NC315 *does not* include the following indicators:

- Contrast/Brightness LED
- Horizontal Position/Horizontal Size LED
- Vertical Position/Vertical Size LED
- Pincushion/Trapezoid LED

Part 1 – System Operation, Configuration and Programming

System Operating Instructions

NC304, NC304LCD Master Operation

Call information will be displayed on the LCD or VGA monitor and will be accompanied by an audible tone. Low, Medium and High priority calls will generate specific call information and tone rates as described in the preceding controls and indicators information. Calls are sorted by priority and time of origination. Calls made to the master station may be answered in one of the following two methods.

Answer a Call Automatically: (Answers the oldest, highest priority call.)

- Press the “TALK” (white) button or pick up the handset. The call tone will be silenced, and communication to the room will be established. If the pre-announce call tone is active, a one-second tone will be heard at the master and patient stations when the “TALK” button is first pressed, or when the handset is picked up.
- Press “TALK” when speaking and release to listen, or if using the handset, speak and listen as desired.
- Press the “RESET” (black) button or hang up the handset when finished. Medium priority, high priority and personal attention calls must be reset at point of origin.

Answer a Call Selectively:

- Enter the room number and bed number for the desired call and press the “TALK” (white) button or pick up the handset. The call tone will be silenced and communication to the room will be established. If the pre-announce call tone is active, a one second tone will be heard at the master and patient stations when the “TALK” button is pressed or when the handset is picked up.
- Press “TALK” when speaking and release to listen, or if using the handset, speak and listen as desired.
- Press the “RESET” (black) button or hang up the handset when finished. Medium priority, high priority and personal attention calls must be reset at point of origin.

Once a call has been answered, the user can place it on hold by pressing the “PAGE” (gray) key. *On hold* status will be indicated by the room number being displayed on the top of the screen in yellow. If the handset is in use, it must be hung up. This allows the user to close the audio connection to the room they were speaking to, but not cancel the call. Once done, the user can handle another call, hang up the handset, and then return to the previous call by pressing “PAGE” and then pressing “TALK” or picking up the handset. If the call is manually selected and reset, the page indicator at the top of the screen will remain and can be cleared by pressing “PAGE” and then “RESET.”

Before connecting to a room (before audio is engaged), a user can press the “PRIVACY” (blue) key or the “PRIORITY” (blue) key to change the settings for that room. Privacy toggles on and off, and Priority cycles through Routine, Personal Attention and Priority. Status changes are indicated on the screen.

If a medium or high priority call is placed while a master station is in communication with another station, the communication path will be closed and the call placed on hold within 8-10 seconds. This prevents an audio path from being accidentally left open, and ensures that medium and high priority calls are annunciated.

Place a Call:

- Enter the room number and bed number on the keypad and press the “TALK” (white) button or pick up the handset. Communication to the room will be established. If the pre-announce call tone is enabled, a one-second tone will be heard when the “TALK” button is pressed or when the handset is picked up. If the station is already in communication with another master, a “PORT BUSY” message will appear.
- Press “TALK” when speaking and release to listen, or if using the handset then speak and listen as desired.
- Press the “RESET” (black) button or hang up the handset when finished.

Part 1 – System Operation, Configuration and Programming

System Operating Instructions

NC304, NC304LCD

Master Operation

continued

This function can be activated if other calls are waiting, but will be overridden by higher priority calls. If the patient station being called is in privacy mode, the master station will not be able to listen to the room station.

Place a Call to Another Master Station:

- Enter the master station number (1 – 8) on the keypad and pick up the handset. If the master station is already in communication, a “PORT BUSY” message will appear. The user must enter only the single digit master number, with no preceding or following zeros.
- Wait for the other master station to respond, and then speak and listen as desired.
- Hang up the handset when finished.

The push to talk feature may be used in lieu of the handset if desired. Instead of picking up the handset, push the “TALK” (white) button to initiate the call to the other master station. Once the call is connected, press “TALK” to speak and release to listen.

Receive a Call from Another Master Station:

- A message box will appear on the screen indicating which master is calling.
- Pick up the handset and then speak and listen as desired.
- Hang up the handset when finished.

The push to talk feature may be used in lieu of the handset if desired. Instead of picking up the handset, push the “TALK” (white) button to communicate to the other master station. Press “TALK” to speak and release to listen.

Request or Cancel Nurse/Aide Service:

- Enter the desired room number and press the “NURSE” (green) or “AIDE” (yellow) button.
- The room number will begin to flash under the appropriate Nurse or Aide column, or if canceling, the number will be removed from the Nurse or Aide column.
- Press the “RESET” (black) button when finished.

Nurse or Aide requests may also be made while communicating with a room station by pressing the “NURSE” or “AIDE” buttons. Once a request is made, the room location will indicate a service call until it has been answered. If the overtime feature has been set, Nurse and Aide requests will trigger call placement to the master station when they exceed the overtime limit. See **SF350B Nurse/Aide Presence Station Operation** for details on responding to service requests. If an SF350B is not in use on the system, staff members can cancel service requests by pressing the “RESET” (red) button on the associated patient station.

Request or Cancel Stat Service:

- Enter the desired room number and pick up the handset to connect audio to the room.
- Press the “STAT” (red) button.
- Hang up handset.

Repeat the above procedure to cancel Stat service. This function requires that an audio connection be established, preventing casual activation or deactivation.

Page a Zone:

- Press the “PAGE” (gray) button and enter the desired zone letter (A – P). Since all zones are letters, the master station will automatically activate the “ALPHA” (white) key, enabling the alternate alpha characters printed on the master’s buttons. If a port or a station within the specified zone is already in use by another master station, a “PORT BUSY” message will appear.

Part 1 – System Operation, Configuration and Programming

System Operating Instructions

NC304, NC304LCD

Master Operation

continued

- Press the “TALK” (white) button to speak, or pick up the handset and speak.
- Press the “RESET” (black) button when finished.

The ability to listen is disabled when this function is engaged.

Page All Assigned Zones:

- Press the “PAGE” (gray) button twice. If a port or a station within the specified zones is already in use by another master station, a “PORT BUSY” message will appear.
- Press the “TALK” (white) button to speak, or pick up the handset and speak as desired.
- Press the “RESET” (black) button when finished.

The ability to listen is disabled when this function is engaged.

Page Nurse/Aide by Presence Registration:

- Press the “PAGE” (gray) button and then press the “ALPHA” (white) button.
- Press the “NURSE” (green) or “AIDE” (yellow) button and then press the # key. If a port or a station within the specified presence area is already in use by another master station, a “PORT BUSY” message will appear.
- Press the “TALK” (white) button to speak, or pick up the handset and speak as desired.
- Press the “RESET” (black) button when finished.

The ability to listen is disabled when this function is engaged.

Page All Stations on the System:

- Press the “PAGE” (gray) button and then the “RESET” (black) button (Note: the reset button is actually being used as the “X” alpha key in this application). If a port or a station on the system is already in use by another master station, a “PORT BUSY” message will appear.
- Press the “TALK” (white) button to speak, or pick up the handset and speak as desired.
- Press the “RESET” button when finished.

The ability to listen is disabled when this function is engaged.

Use Room Monitoring:

Room monitoring provides the staff with the ability to monitor (listen to) up to 8 patient stations simultaneously.

- Press the “MONITOR” (blue) button. The room monitoring box will be displayed.
- Enter the room and bed number for the first station to be monitored, and then press the # key.
- Repeat until all stations to be monitored are entered.
- Press the # key to activate room monitoring.
- Press any button when finished. The entered room numbers will be retained in memory and can be quickly accessed again by pressing the “MONITOR” button again. To clear the entered room numbers, access the Monitor function via the menu as described in the **System Configuration and Programming** section under the **System Functions** menu. It is also possible to clear any individual room from the group by pressing the “MONITOR” button and reentering the number for the device that is already on the list.

Part 1 – System Operation, Configuration and Programming

System Operating Instructions

NC304, NC304LCD

Master Operation

continued

Use Nurse/Aide Follower:

This feature allows the staff to receive call tone annunciation while in a patient's room.

Method 1 – Does not require SF350B Nurse/Aide Presence Stations

- Make sure no calls are pending before engaging the follower function.
- To send the call annunciation to a specific room, enter the room number and press the "FOLLOW" (orange) button.
- The light on the "FOLLOW" button will illuminate, indicating that the function is active. If a VGA monitor is connected to the master, a message box will appear and display the programmed room number.
- Proceed to the room. If a call is placed within the master's zone assignments, the "RESET" (red) light on the follower programmed patient station will illuminate and a tone will sound. This is to inform the staff member that a call is active elsewhere. This call indication can be silenced by pressing the reset button on the patient's station.
- Return to the master station when ready and press the "FOLLOW" button to disengage the feature.

Method 2 – Requires SF350B Nurse/Aide Presence Stations

- Make sure no calls are pending before engaging the follower function.
- To enable a following call annunciation, press the "FOLLOW" (orange) button.
- The light on the "FOLLOW" button will illuminate indicating that the function is active. If a VGA monitor is connected to the master, a message box will appear and indicate that the function is active.
- Proceed to a room and press the registration button for Nurse (green) or Aide (yellow). If a call is placed within the master's zone assignments, the "RESET" (red) light on the associated patient station will illuminate and a tone will sound. This is to inform the staff member that a call is active elsewhere. This call indication can be silenced by pressing the reset button on the patient's station.
- To change rooms, press the appropriate registration button again. Go to the next desired room and press the appropriate registration button. Press it again when leaving the room.
- Return to the master station when ready and press the "FOLLOW" button to disengage the feature.

If master stations share zones, only one master station may use the follower feature at a time.

Taking the Master Station Offline:

Method 1 – Turning it off.

- Unplug the power connector.
- Master fault indications and tones will occur on the other master stations.

Method 2 – Using the keyboard (reference NC304 Master Station Connections).

- Connect the keyboard cable to the PS/2 connection on the back of the NC304.
- Activate the keyboard by pressing "MENU" and then "6." **NOTE:** If the keyboard is already active, this step is unnecessary.
- Press the F11 key, enter a valid username and password (refer to the Set User Name/Password function in the Reconfiguration menu under **System Configuration and Programming** section), and press "3" (selects **Exit to DOS** function). If an event printer is connected to the central equipment, "MASTER <master #> OFFLINE" will be printed. No fault signals will be generated and the master station will retain its address information.

Part 1 – System Operation, Configuration and Programming

System Operating Instructions

NC304, NC304LCD

Master Operation

continued

Method 3 – Setting the Master Address to 0

- Set the master station address to 0 (refer to **System Operation, Configuration and Programming, Set Master ID** function) and then unplug the device.
- If an event printer is connected to the central equipment, “MASTER <master #> OFFLINE” will be printed. No fault signals will be generated.
- If master power is cycled, the master will request entry of an ID after it completes the boot process.

Bringing the Master Station Online:

- Connect power to the NC304 power connector and wait for the master station to boot.
- The message “IDENTIFYING OTHER MASTER STATIONS, PLEASE WAIT” will be displayed in red, along with the master station information box. This message will clear within 2 minutes. Speed up the process by pressing the **Master Seek** button on the central equipment (refer to **Figure 40—NC351(A)/2 Internal Hardware Diagram**).
- The message “READY TO ASSIGN MASTER ID. CONTINUE” will be displayed in white. Assign the master ID (refer to the **System Operation, Configuration and Programming** section, specifically **Set Master ID** function). **NOTE:** If the master station already has an ID programmed into it from a previous operation, it will automatically come up with that ID. This ID can be changed by using the **Set Master ID** function.
- The master station should come online (top line of text on monitor will change from gray to white) with no fault indications within 2 minutes. The Master Seek button can be pressed to shorten this time. If an event printer is connected to the system, the message “MASTER <master #> ONLINE” will be printed.
- Perform the **Restore Local Database** function (refer to **System Operation, Configuration and Programming** section).
- If this is the first time the master is powered up, the **Detect System Stations** function in the **System Functions** menu must be performed.

Radio Paging Operation:

The Tek-CARE® NC300™II Nurse Call System provides support to interface with RF pocket paging applications via the serial ports. When properly configured, the radio paging functions are transparent to the user and happen automatically, with the exception of custom pages that are entered manually by the user. The details of setting this up are covered in the **System Configuration and Programming** section.

Event Printing:

The Tek-CARE® NC300™II Nurse Call System provides support to interface with a serial printer for event printing. When properly configured, the event printing functions are transparent to the user and will happen automatically. The details of setting this up are covered in the **System Configuration and Programming** section. An event printing sample is provided at the end of this manual. Refer to the Table of Contents for the specific location.

View Station Information: Press the “View” (blue) key.

NC306 Master Operation

The NC306 Direct Select Master Station has the same general functions as the NC304 and NC304LED master stations. Incoming calls are displayed on the master’s selector keys, accompanied by an audible tone. (Refer to **Figure 46—Keypad for NC306.**) Low, medium and high priority calls generate differing call tones and flash rates. Calls are answered using one of these two methods:

Part 1 – System Operation, Configuration and Programming

System Operating Instructions

NC306 Master Operation

continued

Answer a Call Automatically: (Answers the oldest, highest priority call.)

- Press the “TALK” (gray) button or pick up the handset. The call tone will be silenced, and communication to the room will be established. If the pre-announce call tone is active, a one-second tone will be heard at the master and patient stations when the “TALK” button is first pressed, or when the handset is picked up.
- Press “TALK” when speaking and release to listen, or if using the handset, speak and listen as desired.
- Press the “RESET” (black) button or hang up the handset when finished. Medium priority, high priority and personal attention calls must be reset at point of origin.

Answer a Call Selectively:

- Press the selector button for the desired room, and press the “TALK” (gray) button or pick up the handset. The call tone will be silenced and communication to the room will be established. If the pre-announce call tone is active, a one second tone will be heard at the master and patient stations when the “TALK” button is pressed or when the handset is picked up.
- Press “TALK” when speaking and release to listen, or if using the handset, speak and listen as desired.
- Press the “RESET” (black) button or hang up the handset when finished. Medium priority, high priority and personal attention calls must be reset at point of origin.

After connecting to a room, a user can press the “PRIVACY” (red) button or the “PRIORITY” (yellow) button to change the settings for that room. Privacy toggles on and off, and Priority cycles through Routine, Personal Attention and Priority. Status changes are indicated by the selector LED:

Privacy	Priority
On: Flashing	Routine: Steady
Off: Steady	Pers. Attn.: Slowly Flashing
	Priority: Fast Flashing

Place a Call:

- Press the selector button for the desired room and pick up the handset or push the “TALK” (gray) button. If the pre-announce tone is enabled, a one-second tone will be heard when the “TALK” button is pressed or when the handset is picked up. If the station is already in communication with another master, the “TALK LED” will flash on the master to indicate that the port is busy.
- Press “TALK” when speaking and release to listen, or if using the handset then speak and listen as desired.
- Press the “RESET” (black) button or hang up the handset when finished.

This function can be activated if other calls are waiting, but will be overridden by higher priority calls. If the patient station being called is in privacy mode, then the master station will not be able to listen to the room station.

Place a Call to Another Master Station:

- Press the “PAGE” (violet) button on the master. LEDs in the first row of selector keys will light to show which masters are connected to the system. Press the selector key for the desired master.
- Press “TALK” when speaking and release to listen, or if using the handset then speak and listen as desired.
- Press the “RESET” (black) button or hang up the handset when finished.

Receive a Call from Another Master Station – See the *Answer a Call Automatically* section above.

Part 1 – System Operation, Configuration and Programming

System Operating Instructions

NC306 Master Operation

continued

Request or Cancel Staff Service:

- Press the selector button for the desired room, and then press the “STAFF” (green) button.
- Press the “RESET” (black) button when finished.

A Staff request may also be made while communicating with a room by pressing the “STAFF” (green) button. Once a request is made, the room location will indicate a service call until it has been answered. If the overtime feature has been set (requires NC304 series master station), Staff requests will trigger call placement to the master station when they exceed the overtime limit. See **SF250 Staff Presence Station Operation** or **SF350B Nurse/Aide Presence Station Operation** for details on responding to Staff requests. If an SF250 or SF350B is not in use on the system, staff members can cancel service requests by pressing the “RESET” button on the associated patient station.

Display Staff Presence and Service Requests:

- Press the “STAFF” (green) button.
- Rooms with Staff Presence are indicated by slow flashing selector LEDs. Rooms with Service Request set are indicated by rapid flashing selector LEDs.
- Press the “RESET” (black) button when finished.

Request or Cancel Stat Service:

- Press the selector button for the desired room, and then press the “STAFF” (green) button twice rapidly. Or, while communicating with a room, press the “STAFF” (green) button twice rapidly.
- Press the “RESET” (black) button when finished.

Page a Zone:

- Press the “PAGE” (violet) button. LEDs in the second and third rows of selector keys will light to show which zones (A–P) are available on the system. Press the selector key for the desired zone. If the selected zone is already in use by another master station, the “TALK LED” will flash on the master to indicate that the zone is busy.
- Press the “TALK” (gray) button to talk, or if using the handset then speak as desired. When this function is engaged, listening is disabled.
- Press “RESET” (black) or hang up the handset when finished.

Page All Assigned Zones; Page All Zones:

- Press “PAGE” (violet) and then “ZONE” (blue) to page all zones assigned to that master station. Press “PAGE” twice to page all zones on the system.
- Press the “TALK” (gray) button to talk, or if using the handset then speak as desired. When this function is engaged, listening is disabled.
- Press “RESET” (black) or hang up the handset when finished.

Page Staff by Presence Registration:

- Press the “PAGE” (violet) button and then press the “STAFF” (green) button.
- Press the “TALK” (gray) button to talk, or if using the handset then speak as desired. When this function is engaged, listening is disabled.
- Press “RESET” (black) or hang up the handset when finished.

Use Staff Follower – This feature allows the staff to receive call tone annunciation while in a patient’s room.

Method 1 – Does not require SF250 or SF350B Nurse/Aide Presence Stations

- Make sure no calls are pending before engaging the follower function.
- To send the call annunciation to a specific room, press the selector button for the specific room and push the “FOLLOW” (orange) button.

Part 1 – System Operation, Configuration and Programming

System Operating Instructions

NC306 Master Operation

continued

- The light on the “FOLLOW” button will blink to show the function is active.
- Proceed to the room. If a call is placed within the master’s zone assignments, the “RESET” (red) light on the follower programmed patient station will illuminate and a tone will sound. This is to inform the staff member that a call is active elsewhere. This call indication can be silenced by pressing the reset button on the patient’s station.
- Return to the master station when ready and press the “RESET” (black) button to disengage the feature.

Method 2 – Requires SF250 or SF350B Nurse/Aide Presence Stations

- Make sure no calls are pending before engaging the follower function.
- To enable a following call annunciation, press the “FOLLOW” (orange) button.
- The light on the “FOLLOW” button will illuminate indicating that the function is active.
- Proceed to a room and press the registration button for Nurse (green) or Aide (yellow). If a call is placed within the master’s zone assignments, the “RESET” (red) light on the associated patient station will illuminate and a tone will sound. This is to inform the staff member that a call is active elsewhere. This call indication can be silenced by pressing the reset button on the patient’s station.
- To change rooms, press the appropriate registration button again. Go to the next desired room and press the appropriate registration button. Press it again when leaving the room.
- Return to the master station when ready and press the “RESET” (black) button to disengage the feature.

If master stations share zones, only one master station can use the follower feature at a time.

Taking the Master Station Offline:

Method 1 – Disconnect the communication cable from the rear of the master station. Master fault indications and tones will occur on the other master stations. Cycling power to the CE will clear the fault.

Method 2 – Using Master Station Button Presses:

- Press the “TALK” (gray) button for 7–10 seconds, until the LED on the “RESET” (black) button is lit.
- Press the “FOLLOW” (orange) button. No fault signals will be generated and the master station will retain its address information.

Bringing the Master Station Online:

Method 1 – Disconnect the communication cable from the rear of the master, wait a few seconds, and then reconnect it. The master will be back online within one minute.

Method 2 – Switch off the power to the central equipment, and then power it up again.

Radio Paging Operation:

The Tek-CARE® NC300™ II Nurse Call System provides support to interface with RF pocket paging applications via the serial ports. When properly configured, the radio paging functions are transparent to the user and will happen automatically. The details of setting this up are covered in the **System Configuration and Programming** section.

Event Printing:

The Tek-CARE® NC300™ II Nurse Call System provides support to interface with a serial printer for event printing. When properly configured, the event printing functions are transparent to the user and will happen automatically. The details of setting this up are covered in the **System Configuration and Programming** section. An event printing sample is provided at the end of this manual. Refer to the Table of Contents for the specific location.

Part 1 – System Operation, Configuration and Programming

System Operating Instructions

IR301-series, IR302-series, IR311-series, IR312-series, IR318-series, IR319-series, IR320-series, SF380-series Patient Station Operation

Refer to Figures 4–8a for the locations, names and functions of the controls and indicators of these devices. A brief description of the operating controls for patient stations follows.

Call-Placed Light: The call-placed light flashes when any call is placed from the patient station.

Reset Switch/In-Use Light: The reset button cancels a call placed from the station. The light illuminates whenever communications from the master station is engaged.

Call Cord Receptacle: There are three kinds of call cord receptacles. The 0.25" round receptacle, found on the IR301-series, IR302-series and SF380-series, uses SF301 and SF302 type call cords. The 8P8C rectangular receptacle, found on the IR311-series and IR312-series, uses SF301 pillow speakers, SF301DIG pillow speakers, SF311 call cords or SF312 call cords. The round DIN receptacle, found on the IR319-series and IR320-series, uses SF401 call cords, SF401P pillow speakers, SF401DIG pillow speakers or SF41-series pillow speakers.

Pull Cord: The IR318-series provides an integral call-initiating pull cord. Patients simply pull on the cord to trigger a call.

Speaker/Microphone: The speaker/microphone is used for voice communications and tone signaling. Due to the high sensitivity of the speaker/microphone, the patient does not need to move close to the device, or to speak above normal levels to be heard.

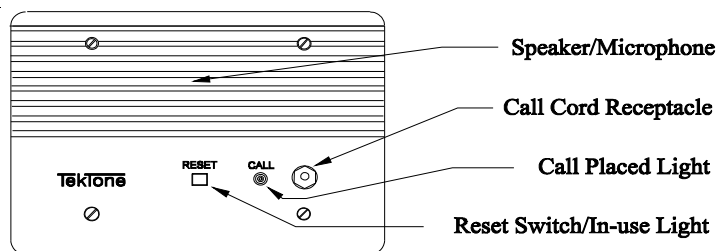

Figure 4 – IR301-series Single Patient Station

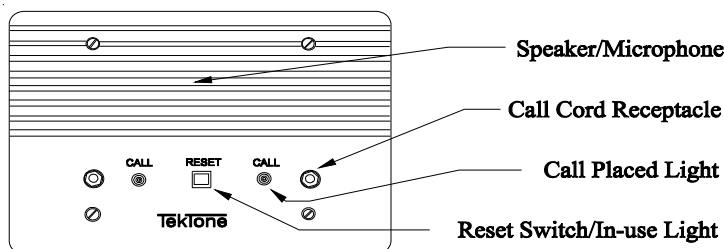

Figure 5 – IR302-series Dual Patient Station

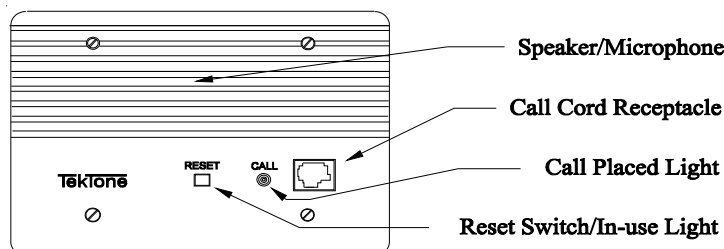

Figure 6 – IR311-series Single Patient Station

Part 1 – System Operation, Configuration and Programming

System Operating Instructions

**IR301-series, IR302-series,
IR311-series, IR312-series,
IR318-series, IR319-series,
IR320-series, SF380-series**
Patient Station Operation
continued

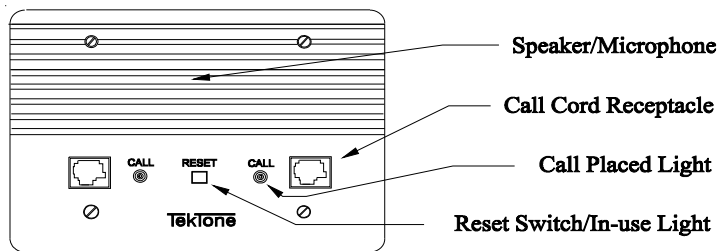

Figure 7 – IR312-series Dual Patient Station

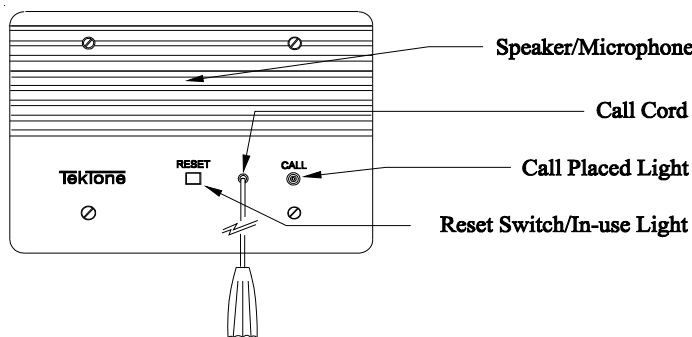

Figure 8 – IR318-series Single Patient Station

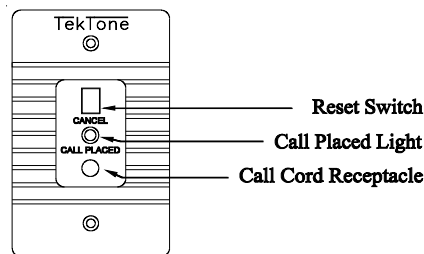

Figure 8a – SF380-series Single Patient Station

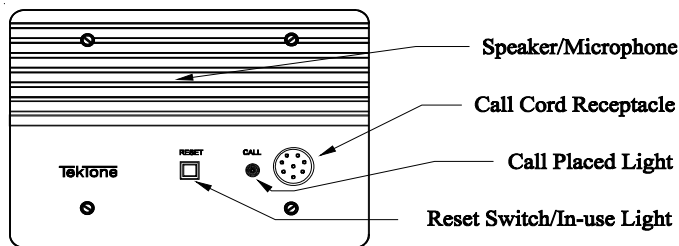

Figure 8b – IR319-series Single Patient Station

Part 1 – System Operation, Configuration and Programming

System Operating Instructions

**IR301-series, IR302-series,
IR311-series, IR312-series,
IR318-series, IR319-series,
IR320-series, SF380-series**
Patient Station Operation
continued

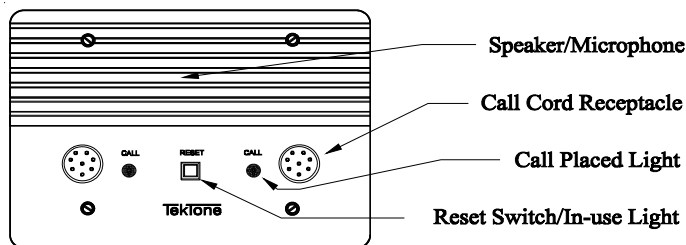

Figure 8c – IR320-series Dual Patient Station

To Place a Call:

- Press the call button on the end of the call cord, or press the red call button with the nurse or cross symbol on the pillow speaker, or pull on the IR318-series call cord. (See Figure 8.)
- Call placement can be verified by the flashing of the Call-Placed Light. A “Cord-Out” call will automatically be placed if a call cord or pillow speaker is removed from the IR301-series, IR302-series, IR311-series, IR312-series, IR319-series, IR320-series or SF380-series. **Note: SF380-series stations must be programmed for Personal Attn. Priority Level.**

To Respond to a Call:

- Reply in a normal voice when spoken to. The audio communication will normally come from the patient station. If IR311-series, IR319-series, IR312-series or IR320-series devices are used with PM311C or PM312C Pillow Speaker Modules and SF301PI, SF301DIG, SF401DIG or SF41-series, audio communications will be from the pillow speaker. Calls placed from SF380-series stations must be handled in person, because the SF380-series do not incorporate audio communication.

To Cancel a Call:

- Press the reset button until the call-placed LED is extinguished.
- Canceling a call placed by the removal of a call cord can be accomplished by replacing the call cord.

Television Controls:

- For IR311-series and IR312-series patient stations with SF301P, or IR319-series and IR320-series patient stations with SF401P, press the button labeled “TV” or with the television symbol . If the television is off, the first press will turn it on. Each successive press will step through the channels until the television turns back off. The volume may be adjusted by rotating the volume control until the desired level is reached. This control only adjusts television audio levels. **NOTE:** Connect only UL® 1410 approved hospital-grade TVs in this application.

Television, Radio and Lighting Controls:

- For IR311-series and IR312-series patient stations with SF301DIG, or IR319-series and IR320-series patient stations with SF401DIG or SF41-series, press the button labeled “TV” to turn the television on or off. Press the channel up/down buttons to change the channel. Press the button labeled “CC” button to turn Closed Captioning on or off. Press the “” button to turn the radio on or off. Press the volume up/down buttons to adjust the volume. Press the room light and read light buttons to turn the room and read lights on and off (requires PM321B or PM322B Lamp Control Module). **NOTE:** Connect only UL® 1410 approved hospital-grade TVs in this application.

Part 1 – System Operation, Configuration and Programming

System Operating Instructions

**IR301-series, IR302-series,
IR311-series, IR312-series,
IR318-series, IR319-series,
IR320-series, SF380-series**
Patient Station Operation
continued

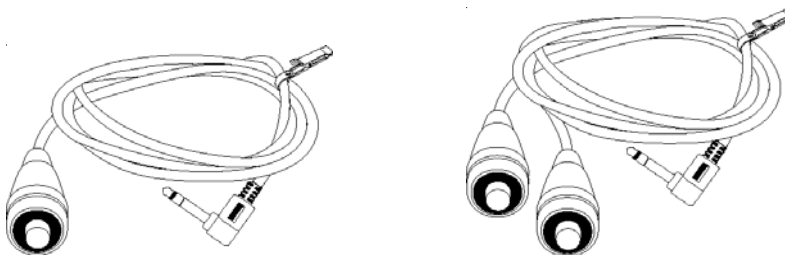

Figure 9 – SF301 and SF302 Call Cords

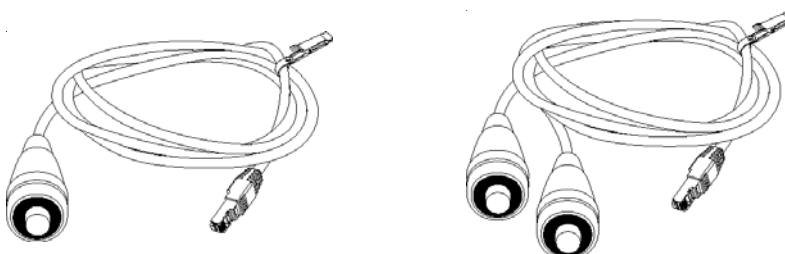

Figure 10 – SF311 and SF312 Call Cords

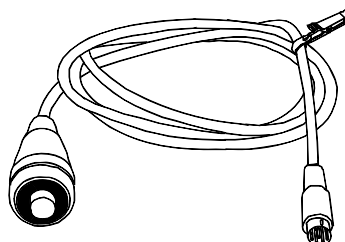

Figure 10a – SF401 Call Cord



Figure 11 – SF301P/SF401P, SF301PI2L/SF401P2L, SF301DIG/SF401DIG,
SF41ZDL and SF41ZKAL Pillow Speakers

Part 1 – System Operation, Configuration and Programming

System Operating Instructions

IR310-series Staff and IR315-series Duty Station Operation

Call Button/Call-Placed Light: The call button is used to place a call to the master. The call light will flash to indicate that a call has been placed. On the duty station, it also indicates call information from other stations sharing the same zones. See **Priority Signals** in this section.

Reset Switch/In-Use Light: The reset button is used to cancel a call placed from the station. The light illuminates whenever communication from the master station is engaged. On the duty station, it also serves as a tone-off button to silence low priority call tone annunciation. Once engaged, the tone will only reactivate after all low priority calls have been cleared. Medium and High priority calls will override this and cannot be silenced.

Emergency Light: This is provided only on the duty station and is used to indicate call information from other stations sharing the same zones.

Priority Signals: The duty station provides an additional annunciation device to the Tek-CARE® NC300™ II System. It will annunciate call information from other stations that share the same zone(s) by doing the following:

Low Priority Calls – The call-placed light will flash and a tone will be emitted every 8 seconds.

Medium Priority Calls – The emergency light and call-placed lights will flash alternately and a repeating tone will be emitted at a half-second rate.

High Priority Calls / Stat Service Request – The emergency light and call-placed light will flash alternately at twice the rate of medium priority calls and a fast repeating tone will be emitted at a quarter-second rate.

Speaker/Microphone: The speaker/microphone is used for voice communications and tone signaling. Due to the high sensitivity of the speaker/microphone, it is not necessary to raise the voice above normal speaking levels to be heard.

To Place a Call: Press the call button. The call-placed light will flash.

To Respond to a Call: Reply in a normal voice when spoken to.

To Cancel a Call: Press the reset button until the call-placed LED is extinguished.

To Silence a Low Priority Call Tone: Press the reset button. **NOTE: If another call is placed, the tone signal will resume until either the reset button is pressed again or the pending calls have been resolved.**

NOTE: The IR315-series Duty Station does not support locally connected code call devices.

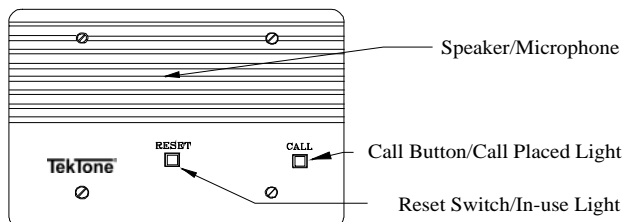

Figure 12 – IR310-series Staff Station

Part 1 – System Operation, Configuration and Programming

System Operating Instructions

IR310-series Staff and IR315-series Duty Station Operation

continued

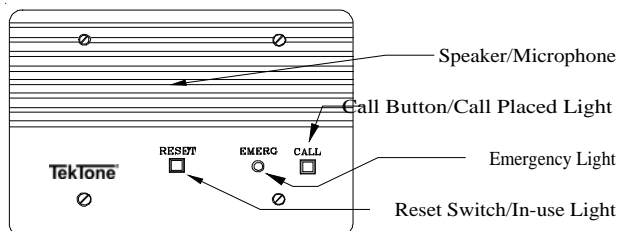

Figure 13 – IR315-series Duty Station (code stations *cannot* be wired to duty stations)

SF337C Water Resistant Pull/Pull Cord Bath Station Operation

Pull-Down/Reset Lever: The pull-down/reset lever is used to place and reset bath priority calls.

Call-Placed Light: The red light flashes to indicate call placement.

To Place a Call: Pull on the red lever, or pull down on the 7' attached cord (if installed).

To Cancel a Call: Push the red lever to the “up” position. Calls must be reset at the point of origin.

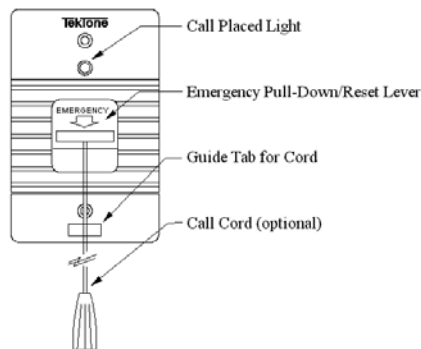

Figure 14 – SF337C Water Resistant Pull/Pull Cord Bath Station

SF340B and SF381 Pull/Pull Cord Bath Station Operation

The SF340B and SF381 devices function in the same manner as the SF337C, but are not water resistant.

SF341B and SF382 Code Call Station Operation

Pull-Down/Reset Lever: The pull-down/reset lever is used to place and reset code priority calls.

Call-Placed Light: The red light flashes to indicate call placement.

To Place a Call: Pull on the blue lever.

To Cancel a Call: Push the blue lever to the “up” position. Calls must be reset at the point of origin.

Part 1 – System Operation, Configuration and Programming

System Operating Instructions

SF341B and SF382 Code Call Station Operation *continued*

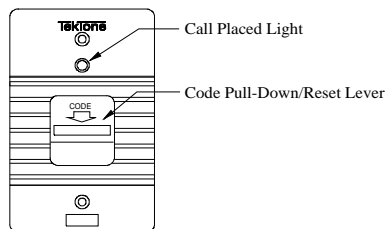

Figure 15 – SF341B and SF382 Code Call Station

SF350B Nurse/Aide Presence Station Operation

Nurse Registration Button: The nurse registration button (green) is used to initiate and cancel a nurse-present signal to the master station. Upon registration activation, it will also reset any routine, personal attention or priority call made from the associated room.

Aide Registration Button: The aide registration button (yellow) is used to initiate and cancel an aide-present signal to the master station. Upon registration activation, it will also reset any routine, personal attention or priority call made from the associated room.

Nurse Registration Light: The green light will flash to indicate a nurse service request and will light steadily to indicate a nurse-present status. This light will go out when the nurse is no longer registered in the room.

Aide Registration Light: The yellow light will flash to indicate an aide service request and will light steadily to indicate an aide-present status. This light will go out when the aide is no longer registered in the room.

To Register Nurse or Aide Presence: Press the green (nurse) or yellow (aide) button.

To Cancel Nurse or Aide Presence: Press the green (nurse) or yellow (aide) button.

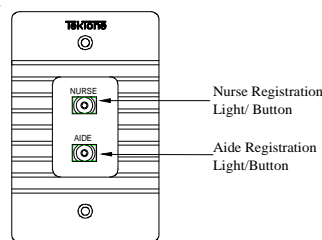

Figure 16 – SF350B Nurse/Aide Presence Station

SF250 Staff Presence Station Operation

Staff Registration Button: The staff registration button (green) is used to initiate and cancel a staff-present signal to the master station. Upon registration activation, it will also reset any routine, personal attention or priority call made from the associated room.

Staff Registration Light: The green LED will flash to indicate a staff service request and will light steadily to indicate a staff-present status. This LED will go out when staff is no longer registered in the room.

Part 1 – System Operation, Configuration and Programming

System Operating Instructions

SF250 Staff Presence Station Operation

continued

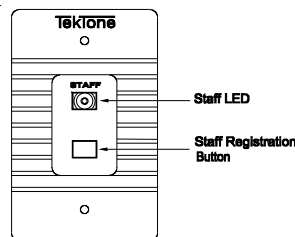

Figure 16a – SF250 Staff Presence Station

LI380, LI384A, LI386-series Dome/Zone Light Operation

The LI series dome/zone lamps provide for local or zone indication of call origin, priority and staff presence. Dome lamp applications are local to a specific room and annunciate call information for that room. Zone lamps are representative of a group (or zone) of stations and will annunciate the highest priority call from that group. The LI380 and LI384A provide the same functions, except that the LI384A provides bulb supervision (faults are indicated at the master station). These devices may serve for dome or zone operation (depending on the station they are connected to). The LI386-series is a stand-alone device that is not used with other stations and is typically used for zone applications. It can, however, support a limited number of devices for local annunciation. The LI386-series is addressed in the same manner as patient and staff stations, and supports no voice communication functions.

Lamp Indications:

High Priority (fast repeating flash):

Code Call	Alternate flashing red and white
Fire	Flashing red (supplementary signal only)
Emergency	Flashing white
Stat Service Request	Alternate flashing green and yellow

Medium Priority (slow repeating flash):

Monitor	Flashing red
Bath	Flashing white
Bed Out	Flashing white
Cord Out	Flashing white
Priority	Flashing white
Nurse Service Request	Flashing green
Aide Service Request	Flashing yellow

Low Priority (steady lamp):

Staff	Steady white
Duty	Steady white
Personal Attention	Steady white
Routine	Steady white
Nurse Present	Steady green
Aide Present	Steady yellow

System Status:

Comm. Fault	No dome light indication
Code Fault	No dome light indication
Lamp Fault	No dome light indication

Part 1 – System Operation, Configuration and Programming

System Configuration and Programming

Configuration and Programming using NC304, NC304LCD Master Stations

This section provides instructions for Tek-CARE® NC300™II software configuration and programming. This process must be carried out by qualified administrative personnel prior to general staff operation. Once completed, the information should require minimal programming changes to comply with periodic facility changes.

A menu tree is provided in Figure 17 to show all of the available menus, functions and how they interrelate. It should be used as a reference for each of the menus and functions that are described in this section. Each item will be listed by its menu or function name and will be followed by a description. All buttons referenced are located on the master station. Certain functions will require the use of additional control keys, which will be indicated on screen at the bottom of display screen.

Menu items are selected by pressing the associated number key as indicated. To return to the previous menu press the * key.

If usernames and passwords are active, the user will be prompted to enter them at appropriate menu transition points. Certain critical menu functions require confirmation before execution. Prompts will be displayed when necessary. **NOTE: Certain menu functions will**

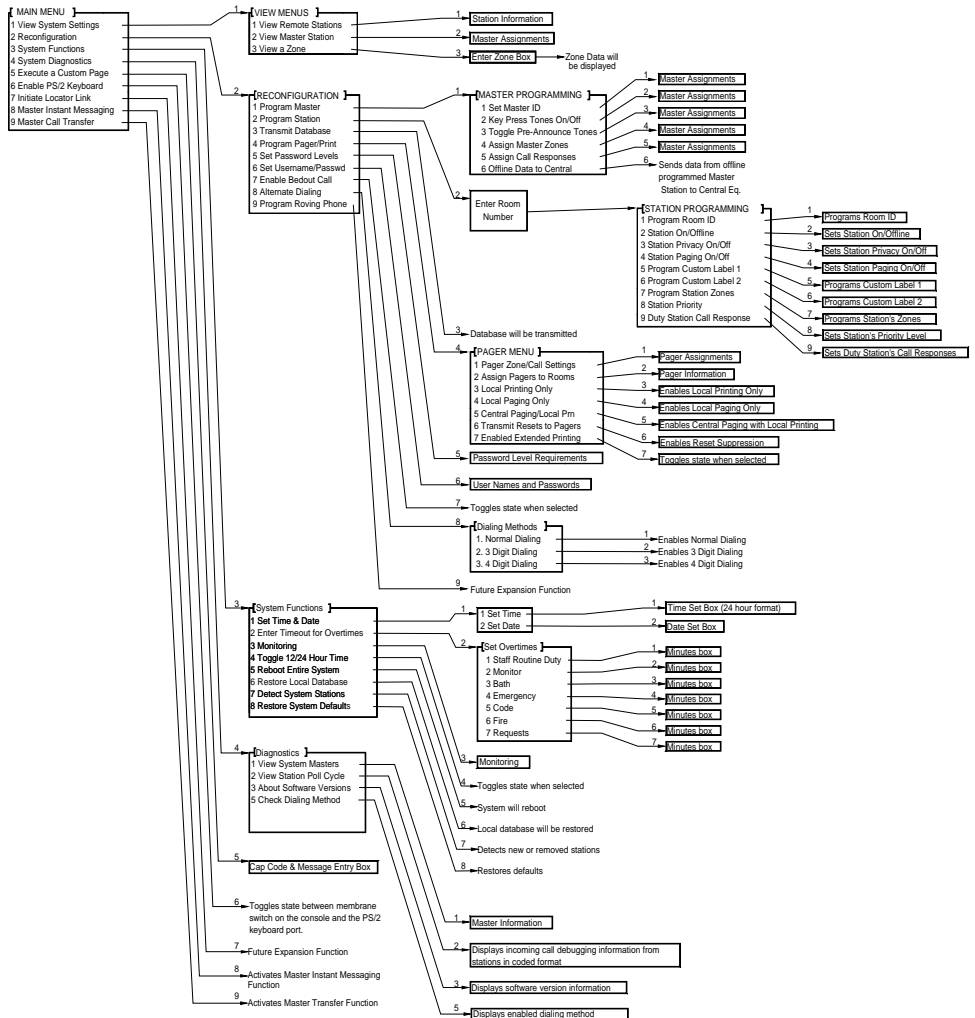

Figure 17 – Menu Map. **NOTE:** There is a larger copy of this drawing before the Programming Sheets.

Part 1 – System Operation, Configuration and Programming

System Configuration and Programming

Configuration and Programming using NC304, NC304LCD Master Stations

continued

erase system programming and affect operational characteristics. Before performing any menu functions, resolve all patient calls and other important system activity.

Main Menu – Press the blue MENU button on the master station. This provides access to the first menu available and is the basic point of entry for all system configuration and programming functions.

1 View System Settings – This displays the **View Menus** menu.

2 Reconfiguration – This displays the **Reconfiguration** menu.

3 System Functions – This displays the **System Functions** menu.

4 System Diagnostics – This displays the **Diagnostics** menu.

5 Execute a Custom Page – This menu function is only accessible if Local Paging Only has been enabled (refer to **Pager Menu**) and requires the use of a keyboard. This function can be accessed by the master station console, but is more fully supported by the keyboard feature. This function allows a user to enter a 3-digit pager cap code and a message up to 36 characters long. The user types in the cap code, a priority code, and the desired message, and then hits ENTER or # to send it. The following priority codes are supported:

A – Regular (Routine), default

B – Medium (Emergency)

C – High (Code)

6 Enable PS/2 Keyboard – Selecting this function toggles between using the master station console and the keyboard.

7 Initiate Locator Link – This function for future development of the personnel location interface function. This expansion feature is currently not available.

8 Master Instant Messaging – (*Feature not currently available.*) Selecting this function opens a window that is used to send text messages to other master stations on the system. When the window opens, a user enters the single-digit master number (1 – 8) for the recipient master station, and then enters a text message up to forty characters long. Then the user presses the ENTER key (in PS/2 keyboard mode) or the # key (in master station console mode). The message will be displayed on the recipient master station, and can be cleared after it is read by pressing the ESCape key (in PS/2 keyboard mode) or the black RESET key (in master station console mode).

9 Master Call Transfer – Selecting this function allows a user to transfer the call and zone responsibilities of a master station to another master station on the system. The user is prompted to enter the Master ID number for the master to receive the transferred information. To exit this mode, press RESET on the master console or ESCape on the keyboard. Multiple master transfers cannot be linear (i.e., transfer from master 1 to master 2 and then transfer master 2 to master 3). If multiple master transfers are desired, users must transfer them in a parallel fashion (i.e., transfer master 1 to master 3, and then transfer master 2 to master 3). **NOTE: The functions initiated by the F11 and F12 keys as described in the Keyboard Section will not work on the master stations involved in the transfer process (sending transfer or receiving transfer). These functions are intentionally locked out in transfer mode.**

0 MSTR/TI Fault Tone Off – This function is only displayed if an NC304/NC304LCD Master Station or NC364A Telephone Interface is in a fault mode. (Therefore, this feature is not shown in Figure 17 – Menu Map.) Selecting this

Part 1 – System Operation, Configuration and Programming

System Configuration and Programming

Configuration and Programming using NC304, NC304LCD Master Stations

continued

function silences a telephone interface fault tone, but does not eliminate visual fault indications. (This option is no longer available.)

View Menus – Press the MENU button and then press 1. This menu provides functions to review the various system devices and their associated configurations. When a menu selection is made, the system displays the appropriate information. Not all information is visible on one screen. Pressing the # key will page down to display additional information.

1 View Remote Stations – This displays a station information box. Entering a room and bed number causes that room's information to be displayed for review.

2 View Master Station – This displays the master station information box for the master station that this function is executed on.

3 View a Zone – This displays a zone entry box (and automatically trigger the ALPHA key). The user can then enter a zone letter, which will cause the zone's information to be displayed. Pressing the # key instead of a zone letter will display all zones on the system.

Reconfiguration – Press the MENU button and then press 2. This menu provides system and device reconfiguration functions.

1 Program Master – This displays the **Master Programming** menu.

2 Program Station – This displays the station programming menu. The user can then enter a room and bed number for the station to be changed.

3 Transmit Database – This function shares the programming information with the other master stations and the central equipment. This feature must only be used when offline programming has been performed on a master station, to allow data that is stored on only one master station to be shared with the rest of the system. Programming changes made to the system while in normal operating mode are automatically updated to the other master stations and the central equipment.

4 Program Pager/Print – This displays the **Pager Menu**.

5 Set Password Levels – This displays the password requirements information box. Information box navigation and setting controls are displayed at the bottom of the screen. Password requirements may be turned on or off for each item listed.

6 Set Username/Password – This menu option allows a user to enter and change usernames and associated passwords. A maximum of 20 usernames and passwords can be entered. When accessed, the user enters his/her username. If the username entered is new to the system, the system jumps to the new username entry section. The new user then enters a password in the password box, and repeats it in the confirmation box, pressing the # or ENTER key after each entry. If the username entered already exists, the system expects the correct password to be entered into the "current password" box. The username and password may then be deleted by pressing the * or the BACKSPACE key, or they may be changed.

The factory default system username is "ADMIN" and the password is "X."

7 Enable Bedout Call – This toggles the enable/disable status for bed out calls. When enabled, this menu option will read "Disable Bedout Call." When enabled, this feature changes a Routine type call to a Bed Out type call, if the call placement is held constantly for more than 7 seconds. This feature works in conjunction with Hill-Rom® SideCom® type beds and the RY351B Hill-Rom® Adapter from TekTone®. **NOTE: This function can only be set at the primary master station.**

8 Alternate Dialing – This displays the **Dialing Methods** menu.

Part 1 – System Operation, Configuration and Programming

System Configuration and Programming

Configuration and Programming using NC304, NC304LCD Master Stations

continued

9 Program Roving Phone – This menu item is for the future development of additional wireless telephone interface functions. This expansion feature is currently not available.

System Functions – Press the MENU button and then press 3. This menu provides access to functions that control or set core system operations.

1 Set Time & Date – This displays the Set Time and Set Date submenu.
NOTE: This function can only be set at the primary master station.

1 Set Time – This opens the Time Set box and allows the user to enter the system time. **NOTE: This entry must be made in 24-hour format (i.e., 3:00 PM is entered as 15:00).**

2 Set Date – This opens the Date Set box and allows the user to enter the system date.

2 Enter Timeout for Overtimes – This displays the **Enter Timeout for Overtimes** menu. This menu lists the call types that can be set for overtime. The user chooses a call type (1 – 7), and then enters a minute value from 00 (off) to 15 in the “minutes box.” This value is the length of time a call can remain unanswered before it is considered overtime and is upgraded in call type. **NOTE: Items that are not currently supported in this version of software will be gray (“grayed out”).**

3 Monitoring – This displays the Monitoring box and clears any previously stored room number information. The user enters a room and bed number to be monitored, and then presses #, repeating the procedure for additional stations. After rooms have been entered, pressing # activates monitoring. Pressing any key ceases room monitoring, as will any incoming call for which the master is zoned.

4 Toggle 12/24 Hour Time – This toggles the state of the time display. Observe the time in the bottom right hand corner while using this function.

5 Reboot Entire System – This triggers a “soft reset.” It is similar to resetting the system by powering it down (often known as a “hard reset”), but power is not removed from the system. System programming information will not be lost when this function is performed. **NOTE: This function resets calls placed on the system that were not activated by a physically latching switch and must therefore only be performed if the system has no calls pending!**

6 Restore Local Database – This causes the master station to obtain programming information from the central equipment. This feature must be used if the master station was used on a different system or is a new/replacement master, and needs to be updated with local system information.

7 Detect System Stations – This causes the system to check for added or removed stations on the system. When activated, “Please Wait” is displayed, and then the system is reset. New stations are assigned default numbers and removed stations are dropped from memory. Preexisting programming information for stations that have not been changed will remain the same. **NOTE: This function must be performed the very first time the system is powered up.**

8 Restore System Defaults – This causes the system to delete all previously programmed information and return to default settings. This also causes the system to look for new or removed system hardware. **NOTE: This process must be performed with caution, because the deleted information cannot be restored and will need to be programmed again!**

Part 1 – System Operation, Configuration and Programming

System Configuration and Programming

Configuration and Programming using NC304, NC304LCD Master Stations

continued

Diagnostics Menu – Press menu, and then press 4. This menu provides diagnostic functions for system troubleshooting.

1 View System Masters – This function displays an information box that displays master status indicators. Up to 8 master stations can be connected to a system, and they are designated 1 through 8. The status of each is indicated as described by the information box's legend.

2 View Station Poll Cycle – This function displays incoming call debugging information from patient stations in a coded format. This data is useful to factory personnel under some troubleshooting circumstances.

3 About Software Versions – This function displays the three versions of software on the nurse call system. They are the MAIN.EXE file (in the nurses' master station), the CENTRAL.BIN file (in the central equipment) and the POLLING.BIN file (in the central equipment). These are the software components that can be upgraded in the field.

5 Check Dialing Method – This function displays the enabled dialing method: normal, 3-digit, or 4-digit.

Master Programming – Press MENU, press 2 and then press 1. This menu provides access to functions for the master station. These must be set individually for each master station at the master station's location. Each menu item displays the master station's information box, and the chosen item will already be selected. The user can then make changes to that field as desired. On-screen instructions are also provided to guide the user.

1 Set Master ID – This allows the user to set the address number of the master station. Master station addresses are 1 through 8.

2 Key Press Tones On/Off – This function controls the reassurance tone emitted for each key press on the master station.

3 Toggle Pre-Announce Tones – This function controls the pre-announce tone emitted from the patient station when an audio path is established.

4 Assign Master Zones – This function controls which zones the master receives calls from. Any or all zones (A through P) may be assigned to each master station. **NOTE: If all zones are deactivated, the master station will not receive any calls! Only qualified personnel may make changes to these settings!**

5 Assign Call Responses – This function controls the types of calls the master station will see for the zones that have been assigned to it. Any or all may be active or inactive. **NOTE: Critical call types, such as Code Call, can be disabled by this function! Only qualified personnel may make changes to these settings!**

6 Offline Data to Central – This function sends custom call label settings from an offline programmed master station to the central equipment for system use. Users must perform this function when a master station has had offline programming performed.

Station Programming – Press MENU, press 2, press 2 and then enter a room and bed number. This menu provides access to functions for stations. Each menu item displays the station's information box, and the chosen item will already be selected. The user can then make changes to that field as desired. On-screen instructions are also provided to guide the user. **Note: After making a station programming change, perform the Transmit Database function** (press MENU, press 2 and then press 3).

1 Program Room ID – Allows user to change the default ID Number to Architectural Room Numbering using both alpha and numeric characters. Bed numbers are also assigned with this function using alpha and numeric characters.

Part 1 – System Operation, Configuration and Programming

System Configuration and Programming

Configuration and Programming using NC304, NC304LCD Master Stations

continued

2 Station On/Offline – Allows user to activate or deactivate the station.

3 Station Privacy On/Off – Allows user to set the patient station's privacy status. If active, the master station cannot receive audio from the patient station unless the patient initiates the call. The patient station will still be able to hear audio from the master station.

4 Station Paging On/Off – Allows user to set paging status. If active, the patient station will be included during audio pages. If it is inactive, the patient station will not be included during audio pages.

5 Program Custom Label 1 – Allows user to enter a custom 16-character label. It is recommended that the PS/2 Keyboard option be used for entry.

6 Program Custom Label 2 – Allows user to enter a custom 16-character label for the second custom label (available for dual patient stations only).

7 Program Station Zones – Assigns any or all zones, A through P.

8 Station Priority – Allows user to set the patient station's priority level (Routine, Pers. Attn. or Priority). **Note: SF380-series stations must be programmed for Personal Attn. Priority Level.**

9 Duty Station Call Response – Controls the types of calls that the duty station will respond to.

The following information is also displayed in the station information box:

- **Port Connection** – Hardware defined by which port stations are connected to on the CE.
- **Address** – Hardware defined by the dipswitch settings on the individual patient station.
- **Priority Status** may also be changed on this screen by pressing the "Priority" (blue) key on the master station. Press the "Priority" key until the desired status is displayed.

Pager Menu – Press MENU, press 2 and then press 4. This menu provides access to the various functions for local radio paging applications. The system can support up to 48 individual radio pagers. Default pager numbers (i.e., cap codes) are 400–447.

1 Pager Zone/Call Settings – This function is used to set the zone assignments (A through P) and call response types for a specific radio pager.

2 Assign Pagers to Rooms – This function allows any or all of the 48 radio pagers to be assigned to a specific room.

3 Local Printing Only, 4 Local Paging Only, 5 Central Paging/Local Prn – These three menu functions work together, and only one of them may be active at any time. The active function is indicated by gray text ("graying out"). The options that are not active are displayed in normal text. **3 Local Printing Only** sends the data generated and relevant to the master station to the local master station serial port. If a serial printer is connected to this port, the data will print out as each event occurs. **4 Local Paging Only** causes the data generated and relevant to the master station to be formatted for RF paging and output to the local master station serial port. If a properly configured NC365A RF transmitter is connected to this port, the formatted call data will be sent to pocket paging units. When this mode is selected, the most recent pager transmission is displayed at the bottom of the screen (NC304 only). **(NOTE: Only one master can be in Local Paging Only mode at one time. If another master is set to this mode, the first master's setting will automatically reset to Central Paging/Local Prn mode.)** **5 Central Paging/Lo-**

Part 1 – System Operation, Configuration and Programming

System Configuration and Programming

Configuration and Programming using NC304, NC304LCD Master Stations

continued

cal Prn causes system call information to be formatted for RF paging and sent to one of the serial ports on the central equipment (refer to **Figure 26—NC300™II System Connection Diagram**). If a properly configured NC365A RF transmitter is connected to this port, the formatted call data will be sent to pocket paging units. The **3 Local Printing Only** function will also be active, as described earlier in this paragraph.

6 Transmit Resets to Pagers – This menu function prevents call reset notifications from being sent out via the RF pocket paging system, if one is connected.

7 Enable Extended Printing – This function works in conjunction with the Local Printing function described under the Pager Menu. When this function is activated, menu activities are printed in addition to the normal call data supported by the Local Printing function. This provides a record of menu activation and of which menu functions were subsequently executed. Selecting this menu item toggles between the enabled and disabled statuses.

Dialing Methods – Press Menu, press 2 and then press 8. This menu provides access to the alternate dialing methods available on the system. **NOTE: Implementing a new dialing method will erase all station ID information and reboot the system. This is done to prepare the system for the new data format. Other programming information will still be retained. When these modes are activated, the system's master to master audio communications features will be disabled, and a new option that is accessed through this menu will appear: Master to Master Audio.**

1 Normal Dialing – This is the default system dialing method. Dialing consists of a 4-digit room number plus a 1-digit bed number (both bed 1 and bed 2 when using dual patient stations). Default numbers are assigned as described in the **System Installation** section under **Equipment Configuration and Settings**.

2 3-Digit Dialing – This reduces dialing of room numbers to 3 digits and no bed number. This method always assumes the bed number is bed 1 (or if it is a dual station, both beds 1 and 2). Default numbers are assigned as described in the **System Installation** section under **Equipment Configuration and Settings**, but do not have the leading 0. When programming room number information in this mode, the first digit and bed numbers are locked out. If calling a dual bed station, the assumed bed number 1 also talks to bed number 2, since their audio is part of the same circuit.

3 4-Digit Dialing – This reduces dialing of room numbers to 3 digits plus a 1-digit bed number (both bed 1 and bed 2 when using dual patient stations). Default numbers are assigned as described in the **System Installation** section under **Equipment Configuration and Settings**, but do not have the leading 0. When programming room number information in this mode, the first digit and second bed number (when using dual stations) will be locked out.

Part 1 – System Operation, Configuration and Programming

System Configuration and Programming

Keyboard Functions

A PS/2 keyboard port is provided to allow connection of a standard PC-type keyboard to the NC304 Master Station for easier data entry. This must only be performed by qualified administrative personnel.

The keyboard is used to edit data and to enter custom radio paging messages, and must not be used to respond to patient calls or for similar nurse call functions. **NOTE:** While using the keyboard, entries are case sensitive. Zone letters and alpha characters used in room and bed numbers must all be capitalized, because the master station console cannot generate lower case letters. Certain keys on the following list must never be used and are so indicated—such as the comma, apostrophe, colon, semicolon and slash. The space bar and shifted characters such as ! and @ must not be used in room numbers, because they cannot be generated at the master station. These characters may be used in room labels.

Esc Key – This acts just as the “RESET” (black) key does on the master station. It cancels most functions and escape menu activities.

F1 Key – This acts just as the “MENU” (blue) key does on the master station. It displays the Main Menu.

F2–F10 Keys – No function.

F11 Key – Uploads or downloads the station database to a laptop computer (see following section).

F12 Key – Updates software (see following section).

1–0 Number Keys – As labeled.

~ ‘ Key – As labeled.

Tab Key – No function.

Caps Lock Key – Do not use—see information at the beginning of this section.

Shift Key – Do not use—see information at the beginning of this section.

Crtl Key – No function.

Windows Key – No function.

Alt Key – No function.

Space Bar – As labeled—see information at the beginning of this section.

A–Z Keys – As labeled.

_ - Key – As labeled.

+ = Key – As labeled.

| \ Key – As labeled.

Backspace Key – This acts just as the * key on the master station. It allows the user to back up through the menus and the programming fields.

{ [Key – As labeled.

}] Key – As labeled.

; : Key – Do not use.

" ' Key – Do not use.

< , Key – Do not use.

> . Key – Do not use.

? / Key – Do not use.

Enter Key – This acts like the master station’s # key. It is used to accept and save most functions.

Insert Key – No function.

Delete Key – No function.

Home Key – No function.

End Key – No function.

Page Up/Down Keys – No function.

Arrow Keys – No function.

Num Lock Key – This must always be active (LED on).

/ Key – Do not use.

*** Key** – See **Backspace Key** functions.

Prt Scrn/SysRq Key – No function.

Scroll Lock Key – No function.

Pause/Break Key – Do not use.

Num Lock LED – This must always be on.

Caps Lock LED – This must always be on.

Scroll Lock LED – This must be off.

Part 1 – System Operation, Configuration and Programming

System Configuration and Programming

NC304 series & NC351(A) series Software Component Upgrades

PLEASE READ THIS ENTIRE SECTION PRIOR TO UPGRADING ANY SOFTWARE COMPONENTS!!!

See *NC306 Software Component Upgrades* for NC306 Masters. To upgrade the various software components that operate the system, the following equipment must be prepared:

- A laptop computer with **DOS** or **Command Prompt** capability. The batch files provided with software upgrades will automatically configure the COM1 port for communication. **NOTE: The laptop computer must be running on battery power, and must not be connected to 120 VAC power.**
- A properly configured null-modem cable:

DB9 Pin	DB9 Pin
3	2
2	3
7	8
8	7
5	5
6	4
4	6

- A PS/2 keyboard.

The user will receive the software component upgrade files via e-mail or diskette. If they have been received via e-mail, the user must open the message and left-click **File** and then left-click **Save Attachments**. This displays a save window. The user must left-click **Desktop** and then left-click **Save**. This will save the files on the **Desktop** area for usage. When the user is done, the files may be moved to another area of the computer for storage, or dragged into the **Recycle Bin** for deletion.

If the files were received on a diskette, the user must insert the diskette into the laptop's disk drive (typically the **A:** drive). The user must then left double-click the **My Computer** icon on the **Desktop**. A window will open, displaying the various drives on the computer. The user must left double-click the drive the diskette was inserted into (typically the **A:** drive, labeled **3½ Floppy A:**). This will cause the window to change to the contents of the diskette. The user must select all files by left-clicking on the topmost file and then hold down the **Shift** key and left-click on the bottommost file. All the available files should be highlighted at this time. The user then presses **Ctrl-C** to copy the files to the **Clipboard**. The user may then close the window by left-clicking the small **X** button in the upper right-hand corner of the window. The window will disappear, displaying the laptop's **Desktop** area. The user next presses **Ctrl-V**, which will paste the files from the clipboard onto the desktop. The files will appear as various icons on the **Desktop**. When the user is done, the files may be moved to another area of the computer for storage, or dragged into the **Recycle Bin** for deletion.

The user will typically receive at least three files in one of the following sets:

<u>Set 1: Console</u>	<u>Set 2: Central</u>	<u>Set 3: Polling</u>
<i>transfer.exe</i>	<i>transfer.exe</i>	<i>transfer.exe</i>
<i>main.exe</i>	<i>central.bin</i>	<i>polling.bin</i>
<i>installm.bat</i>	<i>installc.bat</i>	<i>installp.bat</i>

On occasion, additional files may be sent. If this occurs, a *readme.txt* file will be included that will contain additional instructions for the upgrade process.

Connect one end of the null modem cable to the COM1 port on the laptop computer. Connect the other end of the null modem cable to the serial port of the master station that is to be upgraded. **NOTE:** Central equipment software components must be upgraded from the primary master station (displays double asterisk in upper left hand corner of associated VGA monitor and is addressed as master #1). Master station software components are upgraded locally at each master station.

Part 1 – System Operation, Configuration and Programming

System Configuration and Programming

NC304 series & NC351(A) series Software Component Upgrades

continued

Connect the PS/2 keyboard to the master station PS/2 keyboard port and ensure that it is enabled via the software menus (refer to **Main Menu** under the **System Configuration and Programming** section).

A username and password are required to enter the following modes. Refer to **Reconfiguration** under the **System Configuration and Programming** section if one does not already exist. **NOTE: If the user is upgrading the *central.bin* or *polling.bin* files, the key on the Central Equipment must be turned to a horizontal position.**

Press **F12** on the master station keyboard and enter a valid username and password. A menu will appear with the following options and a cautionary message for users who have not read this section of the manual:

- 1 Update CONSOLE Processor (uses *installm.bat* and *main.exe* files)
- 2 Update CENTRAL Processor (uses *installc.bat* and *central.bin* files)
- 3 Update POLLING Processor (uses *installp.bat* and *polling.bin* files)

On the laptop, use the mouse to left-double-click on the appropriate *install*.bat* file that was previously placed on the desktop. (The laptop screen will display a command prompt window that asks the user to hit the space bar to begin. Do not press the space bar yet.) On the PS/2 keyboard connected to the master station, select the menu option (1, 2 or 3) for the software upgrade option you are installing. On the laptop, press the space bar. At this point the software transfer will begin. The master station screen will go black and display text indicating that it is receiving the file. During file transfer, the **DOS** or **Command Prompt** window will display rows of “T” symbols to represent the transfer process. Transferring the file may take several minutes and must not be interrupted.

If the *main.exe* file is being updated, the master station will reboot. Turn off the central equipment and then turn it back on.

If either the *central.bin* or the *polling.bin* file is being upgraded, after the transfer is complete (EOF and a checksum will be displayed), turn off the central equipment and all master stations. **NOTE: Return the key on the central equipment to the vertical position, and then turn the central equipment and master stations on again. (Failure to return the key to the vertical position could damage the PM353 card!)** Once all devices have booted up, the upgrade is complete. If an error occurs during a software upgrade, contact the factory for assistance (see cover of manual for phone numbers).

Station Database Functions

PLEASE READ THIS ENTIRE SECTION PRIOR TO UPGRADING ANY SOFTWARE COMPONENTS!!! This cannot be performed with NC306 master stations—the system must have at least one NC304 series master station. To upload or download the station database information, you must have the following:

- Three files from TekTone®: *give.bat*, *get.bat* and *transfer.exe*.
- A computer that allows an MS-DOS prompt (i.e., Windows 95, 98, ME, XP).
- A PS/2 keyboard.
- A Tek-CARE® NC300™II system in which the **7 Detect System Stations** function has been performed (located on the **3 System Functions** menu).
- A properly configured null-modem cable:

DB9 Pin	DB9 Pin
3 _____	2 _____
2 _____	3 _____
7 _____	8 _____
8 _____	7 _____
5 _____	5 _____
6 _____	4 _____
4 _____	6 _____

Part 1 – System Operation, Configuration and Programming

System Configuration and Programming

Station Database Functions

continued

Power up the computer, and copy the three files (*give.bat*, *get.bat* and *transfer.exe*) to the computer's Desktop. Be certain that the computer has Caps Lock on (type is in all capital letters).

Connect one end of the null modem cable to the computer's COM1 port. Connect the other end of the null modem cable to the serial port on the primary system master station—master #1 has two asterisks (**) in the upper left corner of the screen.

Connect the PS/2 keyboard to the same master station's PS/2 keyboard port (on the rear of the master) and ensure that it is enabled via the software menus (refer to **Main Menu** under the **System Configuration and Programming** section).

A username and password are required to enter the following modes. Refer to **Reconfiguration** under the **System Configuration and Programming** section if one does not already exist.

Press **F11** on the keyboard and enter a valid username and password. A menu will appear with the following options and a cautionary message for users who have not read this section of the manual:

- 1 Upload Station Database
- 2 Download Station Database
- 3 Exit to DOS

To upload a copy of the station database from the master station to the computer, click on the computer's **Start Button** and then on **Run**. Type "get stations.db" in the box and then click **OK**. Next, select menu option **1 Upload Station Database** on the master station keyboard to start the file transfer. When the process is complete, the master station will return to normal operation and a copy of the file (called *stations.db*) will be on the computer's Desktop.

To download a copy of the station database from the computer to the master station, click on the computer's **Start Button** and then on **Run**. Type "give stations.db" in the box and then click **OK**. Next, select menu option **2 Download Station Database** on the master station keyboard to start the file transfer. Then perform the function **3 Transmit Database** located in the **Reconfiguration Menu** (the transmit database function will take 15–20 minutes to complete). Finally, perform the function **Offline Data to Central** located in the **Master Programming Menu** (press the MENU button, and then press 2, 1, 6).

A user may engage the DOS mode on the master station by selecting **3 Exit to DOS**. Type *main* at the command prompt (C:\>) and press *enter* (PS/2 keyboard) or # (master console) to return the master to normal operation.

The *stations.db* file may be edited globally by using a program called *offline.exe*, which is located on the master station. If the master station is put into DOS mode (as described earlier in this section), the user may run the *offline.exe* program by typing *offline* and then pressing the enter key on the PS/2 keyboard. This will start the program and allow editing of the database file. These commands are GLOBAL and affect all stations and/or settings.

Before making any changes to the *stations.db* file, select menu option **1 Upload Station Database** on the master station (as shown above) to back up the current file to a laptop computer. This is not necessary if all stations are currently configured to system defaults, because system defaults can be restored via menu functions.

The menu structure for the *offline.exe* program is shown in Figure 18. While working in *offline.exe*, press the BACKSPACE key to return to the previous menu.

Part 1 – System Operation, Configuration and Programming

System Configuration and Programming

Station Database Functions

continued

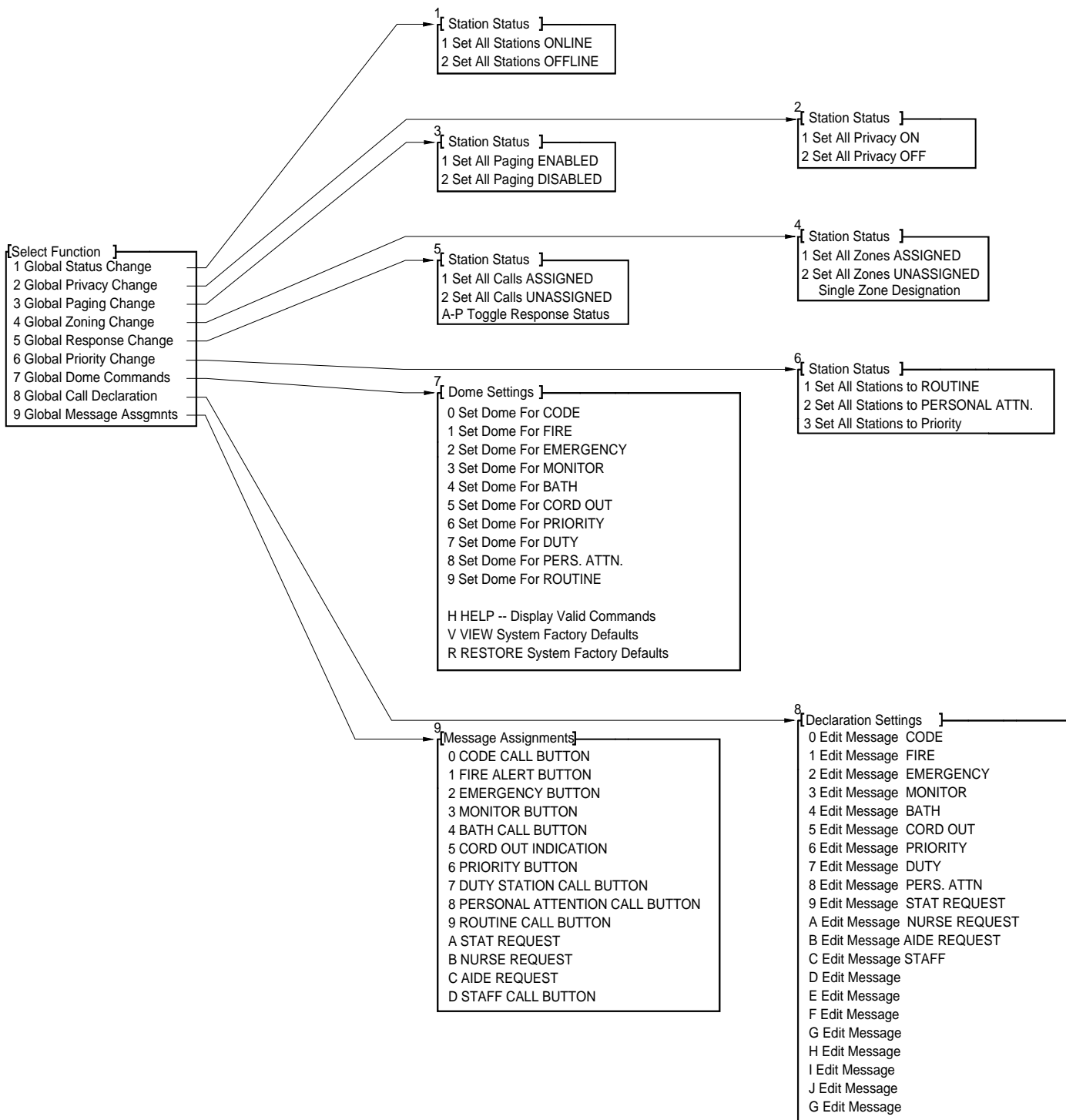

Figure 18 – Offline Programming Map Reference

Part 1 – System Operation, Configuration and Programming

System Configuration and Programming

Station Database Functions

continued

- 1 **Global Status Change** – Selecting this menu option provides these two functions:
 - 1 **Set All Stations ONLINE** – Sets all stations in the database to online status.
 - 2 **Set All Stations OFFLINE** – Sets all stations in the database to offline status. **NOTE:** This will make all stations in the system inactive.
- 2 **Global Privacy Change** – Selecting this menu option provides these two functions:
 - 1 **Set All Privacy ON** – Sets all stations in the database to privacy active.
 - 2 **Set All Privacy OFF** – Sets all stations in the database to privacy inactive.
- 3 **Global Paging Change** – Selecting this menu option provides these two functions:
 - 1 **Set All Paging ENABLED** – Sets all stations enabled for receiving audio pages.
 - 2 **Set All Paging DISABLED** – Sets all stations disabled for receiving audio pages.
- 4 **Global Zoning Change** – Selecting this menu option provides these three functions:
 - 1 **Set All Zones ASSIGNED** – Sets all zones (A-P) active for all stations on the system.
 - 2 **Set All Zones UNASSIGNED** – Sets all zones (A-P) inactive for all stations on the system. **NOTE: This command will disable all system indication of station calls. Users must verify that zones are properly set after programming is completed!!**

Single Zone Designation – Users can access this function simply by entering the zone letter (A-P) that they want activated for all stations. If the user enters “A,” then Zone A will be activated for all stations on the system.
- 5 **Global Response Change** – Selecting this menu option provides these three functions:
 - 1 **Set All Calls ASSIGNED** – Sets all call types (Routine, Code, etc.) active for display.
 - 2 **Set All Calls UNASSIGNED** – Sets all call types (Routine, Code, etc.) inactive for display. **NOTE: This command disables all system indication of station calls. Verify that call displays are properly set after programming is completed!!**

A-P Toggle Response Status – Sets the selected call type active for display according to the following list:

A	–	Code
B	–	Fire
C	–	Emergency
D	–	Monitor
E	–	Bath
F	–	Cord Out
G	–	Priority
H	–	Duty
I	–	Personal Attention
J	–	Routine/Staff
K–P	–	Currently reserved for custom applications

Stat/Nurse/Aide call types are not selectable for this function. This function may be performed multiple times to activate several types of call displays.
- 6 **Global Priority Change** – Selecting this menu option provides these three functions:
 - 1 **Set All Stations to ROUTINE** – Sets all stations to *Routine* call level.
 - 2 **Set All Stations to PERSONAL ATTN.** – Sets all stations to *Personal Attention* call level.
 - 3 **Set All Stations to PRIORITY** – Sets all stations to *Priority* call level.

Part 1 – System Operation, Configuration and Programming

System Configuration and Programming

Station Database Functions

continued

7 Global Dome Commands – Selecting this menu option provides the following 13 functions. **NOTE:** Changes are stored in the NC304(LCD) Master Station, and must be reprogrammed if master #1 is replaced for any reason.

0 Set Dome For CODE – This allows the user to change the dome light and tone patterns for *Code* calls. The factory system default setting is 96.

1 Set Dome For FIRE – This allows the user to change the lamp and tone patterns for *Fire* calls. The factory system default setting is 75.

2 Set Dome For EMERGENCY – This allows the user to change the dome light and tone patterns for *Emergency* calls. The factory system default setting is 72.

3 Set Dome For MONITOR – This allows the user to change the dome light and tone patterns for *Monitor* calls. The factory system default setting is 71.

4 Set Dome For BATH – This allows the user to change the dome light and tone patterns for *Bath* calls. The factory system default setting is 68.

5 Set Dome For CORD OUT – This allows the user to change the dome light and tone patterns for *Cord Out* calls. The factory system default setting is 68.

6 Set Dome For PRIORITY – This allows the user to change the dome light and tone patterns for *Priority* calls. The factory system default setting is 68.

7 Set Dome For DUTY – This allows the user to change the dome light and tone patterns for *Duty* calls. The factory system default setting is 52.

8 Set Dome For PERS.ATTN. – This allows the user to change the dome light and tone patterns for *Priority* calls. The factory system default setting is 68.

9 Set Dome For ROUTINE – This allows the user to change the dome light and tone patterns for *Routine* calls. The factory system default setting is 52.

H HELP– Display Valid Commands – This window lists all valid dome light and tone combinations. Users must consult this list for reference when changing dome light and tone patterns. Color references indicate which light is being set and rate terms refer to tone settings. Columns at the top indicate dome light activation patterns (i.e., steady, flashing, etc.).

V VIEW System Factory Defaults – This window provides a reference list for all Factory system default dome light and tone pattern settings.

R RESTORE System Factory Defaults – This function resets all dome light and tone patterns back to Factory system defaults. **NOTE: Users must verify that all call types provide the desired call indication after programming is completed!!**

8 Global Call Declaration – Selecting this menu option provides the following 21 functions. **NOTE:** Call declarations can be a maximum 10 characters, and affect all stations. Press ENTER when finished editing. If changes are made, execute the **Offline Data to Central** command from the **Master Programming Menu** (press MENU, 2, 1 and then press 6).

0 Edit Message CODE – This function allows users to alter the displayed description of *Code* calls (i.e., CODE could be changed to CRASH CART).

1 Edit Message FIRE – This function allows users to alter the displayed description of *Fire* calls.

2 Edit Message EMERGENCY – This function allows users to alter the displayed description of *Emergency* calls.

3 Edit Message MONITOR – This function allows users to alter the displayed description of *Monitor* calls.

4 Edit Message BATH – This function allows users to alter the displayed description of *Bath* calls.

Part 1 – System Operation, Configuration and Programming

System Configuration and Programming

Station Database Functions

continued

5 Edit Message CORD OUT – This function allows users to alter the displayed description of *Cord Out* calls.

6 Edit Message PRIORITY – This function allows users to alter the displayed description of *Priority* calls.

7 Edit Message DUTY – This function allows users to alter the displayed description of *Duty* calls.

8 Edit Message PERS. ATTN – This function allows users to alter the displayed description of *Personal Attention* calls.

9 Edit Message STAT REQUEST – This function allows users to alter the displayed description of *Stat Request* calls.

A Edit Message NURSE REQUEST – This function allows users to alter the displayed description of *Nurse Request* calls.

B Edit Message AIDE REQUEST – This function allows users to alter the displayed description of *Aide Request* calls.

C Edit Message STAFF REQUEST – This function allows users to alter the displayed description of *Staff Request* calls.

D through G are reserved for custom message applications.

9 Global Message Assgmnts – This series of functions reassigns existing assigned labels to the various hardware call inputs on the patient stations. If the call label declarations have been changed in the **8 Global Call Declaration** menu, the changes will also be displayed in the selection window. Multiple assignments of the same label are permitted. When one of the options below is selected, the current list of hardware input labels is displayed, and the user may then create new label assignments. **NOTE: These functions will not affect hardware priorities. For example, if Code Call inputs are reassigned to Bath Calls, they will still have the display priority of Code Calls. This functionality cannot be altered through software.** Selecting this menu option provides these 14 functions:

0 CODE CALL BUTTON – Reassigns the *Code* call hardware input label.

1 FIRE ALERT BUTTON – Reassigns the *Fire* call hardware input label.

2 EMERGENCY BUTTON – Reassigns the *Emergency* call hardware input label.

3 MONITOR BUTTON – Reassigns the *Monitor* call hardware input label.

4 BATH CALL BUTTON – Reassigns the *Bath* call hardware input label.

5 CORD OUT ANNUNCIATION – Reassigns the *Cord Out* call hardware input label.

6 PRIORITY BUTTON – Reassigns the *Priority* call hardware input label.

7 DUTY STATION CALL BUTTON – Reassigns the *Duty* call hardware input label.

8 PERSONAL ATTENTION CALL BUTTON – Reassigns the *Personal Attention* call hardware input label.

9 ROUTINE CALL BUTTON – Reassigns the *Routine* call hardware input label.

A STAT REQUEST – Reassigns the *Stat* call hardware input label.

B NURSE REQUEST – Reassigns the *Nurse Request* call hardware input label.

C AIDE REQUEST – Reassigns the *Aide Request* call hardware input label.

D STAFF CALL BUTTON – Reassigns the *Staff* call hardware input label.

Part 1 – System Operation, Configuration and Programming

System Configuration and Programming

Configuration and Programming using NC306 Master Stations

Station Privacy – Allows the user to set the patient station’s privacy status. If active, the master station cannot receive audio from the patient station unless the patient initiates the call. The patient station will still be able to hear audio from the master station.

Show a Remote Station’s Privacy:

- Press the selector button for the desired room, and then press the “PRIVACY” (red) button to show the station’s current privacy setting.
- Press the “RESET” (black) button *twice* when finished.

Set a Remote Station’s Privacy On/Off:

- Press the selector button for the desired room, and then press the “PRIVACY” (red) button to show the station’s current privacy setting.
- Press the “PRIVACY” (red) button again to toggle privacy on/off.
- Press the “RESET” (black) button *twice* to save the current setting.

Show All Remote Stations with Privacy On:

- Press the “PRIVACY” (red) button. Selector LEDs will light to show which rooms have Privacy on.
- Press the “RESET” (black) button when finished.

Station Paging On/Off – Allows user to set paging status of remote stations. If active, the patient station will be included during audio pages. If it is inactive, the patient station will not be included during audio pages.

- Press the selector button for the desired station, and then press the “ZONE” (blue) button. The LED of the selector button marked “0” indicates station paging status: On to receive pages, or Off to ignore pages.
- Press the “0” button to toggle paging on/off.
- Press the “RESET” (black) button *twice* when finished.

Station Priority – Patient stations can be set to one of three priority levels: Routine, Personal Attention or Priority. The default is Routine. A Routine station places a low priority call that can be reset from either the master station or from the originating station. A Personal Attention station also places a low priority call, but the call can only be reset from the originating station. A Priority station places a medium priority call, indicated at the master with a blinking selector LED and a rapid tone. A Priority call can only be reset at the originating station. **Note: SF380-series stations must be programmed for Personal Attn. Priority Level.**

Show a Remote Station’s Priority:

- Press the selector button for the desired room, and then press the “PRIORITY” (yellow) button to show the station’s current Priority level.
- Press the “RESET” (black) button *twice* when finished.

Change a Remote Station’s Priority:

- Press the selector button for the desired room, and then press the “PRIORITY” (yellow) button to show the station’s current Priority level.
- Each additional press of the “PRIORITY” (yellow) button steps through the three priorities, indicated by the state of the station selector’s LED: steady for Routine, slow flash for Personal Attention, or rapid flash for Priority.
- Press the “RESET” (black) button *twice* to save the current setting.

Show All Personal Attention and Priority Remote Stations:

- Press the “PRIORITY” (yellow) button. Selector LEDs will light to show which rooms have non-Routine Priority. Selector LEDs will slow flash for Personal Attention, and rapid flash for Priority.
- Press the “RESET” (black) button when finished.

Program Station Zones – Assigns a remote station to any or all zones, A through P.

Show a Remote Station’s Zones:

- Press the selector button for the desired station, and then press the “ZONE” (blue) button. Set zones are shown on the Selector LEDs in the second and third rows. (The second row shows zones A–J, and the first six keys of the third

Part 1 – System Operation, Configuration and Programming

System Configuration and Programming

Configuration and Programming using NC306 Master Stations

continued

row show zones K–P.)

- Press the “RESET” (black) button *twice* when finished.

Set a Remote Station’s Zones:

- Press the selector button for the desired station, and then press the “ZONE” (blue) button. Set zones are shown on the selector button LEDs in the second and third rows. (The second row shows zones A–J, and the first six buttons of the third row show zones K–P.)
- Each press of a zone’s selector button toggles between adding or removing a station from that zone, indicated by the state of that selector button’s LED: On when added to the zone, Off when removed from the zone.

Note: While in this programming mode, the first column of station selector buttons indicates various settings which can be activated or deactivated. Settings are:

0 – Paging Status On/Offline

1 – Station On/Offline

2 – Privacy On/Off

3 – Routine Call Level

4 – Personal Attention Call Level

5 – Priority Call Level

- Press the “RESET” (black) button *twice* when finished.

Station On/Offline – Allows user to activate or deactivate a remote station.

- Press the selector button for the desired station, and then press the “ZONE” (blue) button. The LED of the selector button marked “1” indicates on/offline status.
- Press the “1” button to toggle the station status on/offline.
- Press the “RESET” (black) button *twice* when finished.

Assign Master Zones – This function controls which zones the master receives calls from. Any or all zones (A through P) may be assigned to each master station. **NOTE: If all zones are deactivated, the master station will not receive any calls! Only qualified personnel may make changes to these settings!**

- Push the “ZONE” (blue) button. Master’s zones are indicated by the LED status of the selector keys in the second and third rows. Zones A–J are shown on the second row; zones K–P are shown on the first six keys of the third row.
- To add or remove a zone from the master, press the zone’s key to toggle its status.
- Press the “RESET” (black) button when finished.

Master Station Key-Press Tones On/Off – This function controls the reassurance tone emitted for each key press on the master station. To turn this feature on or off:

- Press the “ZONE” (blue) button.
- Press the “0” button to toggle key-press tones on/off.
- Press the “RESET” (black) button when finished.

Toggle Pre-Announce Tones – This function controls the pre-announce tone emitted from the patient station when an audio path is established. To turn this feature on or off:

- Press the “ZONE” (blue) button.
- Press the “1” button to toggle preannounce tones on/off.
- Press the “RESET” (black) button when finished.

Master Station Guidance LEDs On/Off – Guidance LEDs uses function key LEDs to show which functions are currently available. To turn this feature on or off:

- Press the “ZONE” (blue) button.
- Press the “2” button to toggle Guidance LEDs on/off.
- Press the “RESET” (black) button when finished.

Part 1 – System Operation, Configuration and Programming

System Configuration and Programming

Configuration and Programming using NC306 Master Stations

continued

System Radio Paging Mode:

- Press the “ZONE” (blue) button.
- Press the desired mode’s button—its LED will light:
 - 3 – No central radio paging
 - 4 – Central paging enabled, call resets not sent to pagers.
 - 5 – Central paging enabled, call resets sent to pagers.
- Press the “RESET” (black) button when finished.

Set System Time & Date:

- Press the “TALK” (gray) button for 7–10 seconds, until the LED on the “RESET” (black) button is lit.
- Press the “PRIVACY” (red) button.
- Enter the time using the first row of selector keys (add a leading “0” if necessary): Press two digits for the hour, press two digits for the minutes, and then press “0” for a.m., or “1” for p.m.
- The “PRIVACY” (red) button’s LED will be flashing, to indicate that the time has been accepted.
- Enter the date using the first row of selector keys (add a leading “0” if necessary): Press two digits for the month, press two digits for the date, and then press two digits for the year. The master station automatically returns to normal mode.

Reboot Entire System – This triggers a “soft reset.” It is similar to resetting the system by powering it down (often known as a “hard reset”), but power is not removed from the system. System programming information will not be lost when this function is performed. **NOTE: This function resets calls placed on the system that were not activated by a physically latching switch and must therefore only be performed if the system has no calls pending!**

- Press the “TALK” (gray) button for 7–10 seconds, until the LED on the “RESET” (black) button is lit.
- Press the “RESET” (black) button.

Restore Local Database – This causes the master station to obtain programming information from the central equipment. This feature must only be used if the master station was used on a different system or is a new/replacement master, and needs to be updated with local system information. This process is carried out automatically when a new master station is connected to the system and is assigned an address.

- Press the “TALK” (gray) button for 7–10 seconds, until the “RESET” (black) button’s LED is lit.
- Press the “PAGE” (violet) button. The database upload takes up to five minutes, depending upon system size. Master station control returns automatically.

Detect System Stations – This causes the system to check for added or removed stations on the system, after which it will reboot.

- Press the “TALK” (gray) button for 7–10 seconds, until the LED on the “RESET” (black) button is lit.
- Press the “STAFF” (green) button.

Restore System Defaults – This causes the system to delete all previously programmed information and return to default settings. This also causes the system to look for new or removed system hardware. The system will then reboot. **NOTE: This process must be performed with caution, because the deleted information cannot be restored and will need to be programmed again!**

- Press the “TALK” (gray) button for 7–10 seconds, until the LED on the “RESET” (black) button is lit.
- Press the “ZONE” (blue) button.

Part 1 – System Operation, Configuration and Programming

System Configuration and Programming

Programming Pagers and Remote Stations with the NC306 Master Station

Programming the system for radio pocket pagers and remote station features requires a PC running terminal emulation software (such as HyperTerminal, included with Microsoft® Windows®).

- Plug a standard null modem cable between the serial port on the back of the NC306 master station and the serial port on the PC.
- Set up the terminal emulator for no parity, 8 data bits, 1 stop bit and 19200 baud.
- Press the NC306 “TALK” (gray) button for 7–10 seconds, until the LED on the “RESET” (black) button is lit.
- Press the NC306 “PRIORITY” (yellow) button.
- The PC monitor will display the following menu:
 - PG – PAGER SETUP
 - PS – PROGRAM STATION
 - LP – LEAVE PROGRAMMING (returns the NC306 master station to normal operation)
 - PL – SET POINT LIMITS
- Other keys that are used:
 - ENTER – stores changes (if any) made to current option and moves to the next option, or exits in pager setup functions.
 - / (slash) – returns to the main menu during program station functions.
 - .(period) – switches from the current point being programmed to the next (higher) select point, and also dumps any changes made to the current point.

Radio Pager Programming – The radio pager programming options are, in order: Pager Number Assignments, Zone Assignments and Call Type Assignments.

- Type PG **ENTER**. The display will show all the pager numbers (0 through 47) and their associated pager cap codes.
- Type the pager number (0–47) to be programmed, and press **ENTER**. The display will show the cap code currently assigned to that pager number. Type a new 3-digit cap code, and press **ENTER**.
- Type the zone letters (A–P) assigned to this pager, separated by commas, and press **ENTER**.
- Type the letters of call types to be sent to this pager, separated by commas, and press **ENTER**. Valid call types are shown on the display. They are:

A – Code	F – Cord Out	J – Personal Attn
B – Fire	G – Priority	K – Routine
C – Emergency	H – Duty	L – Stat Request
D – Monitor	I – Staff	M – Staff Request
E – Bath		
- Type # (pound) and press **ENTER** to save the settings for this pager.

Station Programming – By default, stations are assigned to the NC306 selector buttons beginning with the lowest physical address on the lowest numbered port. The stations are assigned to the selector buttons sequentially, starting with the top button in the left row (selector button 0), continuing down each row in sequence, and ending with the bottom button in the right row (selector button 49). After all 50 selector buttons have been assigned to stations, any additional stations are ignored—unless an NC255 Master Station Expander is used to add 50 more selector buttons to the NC306 (adding selector buttons 50 through 99).

The Program Station function allows the selector button assignments to be changed from the defaults, so that a particular selector button can be associated with any station on any port.

Part 1 – System Operation, Configuration and Programming

System Configuration and Programming

Programming Pagers and Remote Stations with the NC306 Master Station

continued

The station programming options are, in order: Assign Station to Selector Button, Station ID, Bed Numbers, Station Labels Single/Dual Patient Stations, Audio Page On/Off, Online/Offline, Privacy, Call Priority and Station Zones. (The last four functions can also be programmed using the NC306 master's keypad.)

- Type **PS ENTER**. The display will show “POINT (0–99).”
- Type the number (0–99) of the selector button to be programmed, and press **ENTER**. The LED on that selector button will start flashing, and the display will show the physical address of the port and station assigned to that selector button.
- Press **ENTER** to skip to next option, or
Type the physical address of the port and station physical address to be assigned to this selector button, and press **ENTER**. (Example: “07,15 **ENTER**” assigns the station on port 7 with dipswitch setting 15 to this selector button.)
- Press **ENTER** to skip to next option, or
Type the 4-character alphanumeric room ID to be assigned to the station associated with this selector button, and press **ENTER**. (Station IDs are used by event printing, pagers and NC304/LCD masters.)
- Press **ENTER** to skip to next option, or
Type the bed number(s) to be assigned to the station, and press **ENTER**. (Example: “R,L **ENTER**” changes the bed1 and bed2 extensions of a dual station to R and L. The extensions are used by event printing, pagers and NC304/LCD masters.)
- Press **ENTER** to skip to next option, or
Type a 1–16 character alphanumeric label for bed 1, and press **ENTER**. (Alphanumeric labels are displayed on NC304/LCD masters with VGA display monitors.)
- Press **ENTER** to skip to next option, or
Type a 1–16 character alphanumeric label for bed2, and press **ENTER**.
- Press **ENTER** to skip to next option, or
Type **N** and then press **ENTER** to turn Station Paging Off, or
Type **Y** and then press **ENTER** to turn Station Paging On. (When station paging is on, the station will receive audio pages.)
- Press **ENTER** to skip to next option, or
Type **N** and then press **ENTER** to take the Station Offline, or
Type **Y** and then press **ENTER** to put the Station Online. (Take a station offline when it must be switched off or physically removed from the system.)
- Press **ENTER** to skip to next option, or
Type **N** and then press **ENTER** to set Station Privacy off, or
Type **Y** and then press **ENTER** to set Station Privacy on. (When station privacy is on, the master station cannot receive audio from the patient station unless the patient station initiates the call. The patient station will still be able to hear audio from the master station.)
- Press **ENTER** to skip to next option, or
Type **0**, and then press **ENTER** to set Station Priority to Routine, or
Type **1**, and then press **ENTER** to set Station Priority to Personal Attention, or
Type **2**, and then press **ENTER** to set Station Priority to Priority.
- Press **ENTER** to skip to the end, or
Type the zone letters (A–P) assigned to this station, or press **0** (zero) to assign no zones to this station, and press **ENTER**.
- To save changes, press **#** (pound) and then **ENTER**, or
To discard changes, just press **ENTER**.

Part 1 – System Operation, Configuration and Programming

System Configuration and Programming

Programming Pagers and Remote Stations with the NC306 Master Station

continued

Set Point Limits – Use this function to assign a specific port and ID number to the first selector key on the master station. The master station will then sequentially assign the remaining selector keys to the next 50 valid remote stations (100 stations when using a NC255 Master Expander).

- Type **PL ENTER**. Type Y or N to indicate presence of an NC255 Master Expander.
- Type the port number and address of the station to be assigned to the first selector key. (Type 1,00 to return the master station's button assignments to default.)
- Perform the **Detect System Stations** function (press "TALK" until the "RESET" LED is lit. Then press "STAFF:"). This sequentially assigns the remaining keys to increasingly higher port/addresses.

NC306 series Software Component Upgrades

PLEASE READ THIS ENTIRE SECTION PRIOR TO UPGRADING ANY SOFTWARE COMPONENTS!!! See Page 33 for NC304 series & NC351(A) series Software Component Upgrades.

- Turn off the Central Equipment (NC351(A) or NC351(A)/2) connected to the NC306 master station that is to be upgraded. Disconnect the NC306 master station and bring it to the Central Equipment. Then plug the NC306 directly into the Central Equipment to facilitate programming and to ensure that the programming voltage is at the correct level.
- Open the NC306 chassis by removing 5 screws. The tool used to remove these is a Robinson or Scrulox #0 screwdriver, TekTone® part number HT004. **NOTE:** One screw is concealed by the sliding tray.
- Move the jumper near the dipswitch to the programming position (see *Figure 22a*).
- On the NC306, move dipswitch number 6 to the ON position (closed).
- Turn on the Central Equipment.
- Connect a standard serial cable from the laptop computer to the serial port on the NC306 Master Station. **NOTE: The laptop computer must be running on battery power, and must not be connected to 120 VAC power.**
- Copy *send.exe* and *387_0x.bin* to the desktop of the laptop computer (where *x* is the file's version number, for example: *387_03.bin*).
- On the laptop, open a DOS or COMMAND window. This should bring you to the *C:\WINDOWS* directory.
- On the laptop, type *cd desktop* and press the **ENTER** key. This will move you into the *C:\WINDOWS\DESKTOP* directory, where the files are located.
- On the NC306, move dipswitch number 7 to the ON position and then back to the OFF position.
- On the laptop, type *send 387_0x.bin* (where *x* is the file's version number, for example: *send 387_03.bin*) and press the **ENTER** key.
- As packets are sent, information will be displayed on the laptop's screen. There will be 4095 packets sent.
- Turn off the Central Equipment. Disconnect the serial cable between the laptop and the NC306.
- Place the programming jumper back in its original position, and move dipswitch number 6 back to the OFF position.
- Reassemble the NC306 Master Station, restore it to its original location, and reconnect it. Then, turn on the Central Equipment.

Part 2 – System Installation, Maintenance and Troubleshooting

System Installation

- Step 1:** Read the following information prior to installing the Tek-CARE® NC300™II system equipment. The installer must be familiar with the system and its installation requirements and guidelines.
- Step 2:** Determine equipment locations.
- Step 3:** Install system wiring.
- Step 4:** Install housings.
- Step 5:** Use ohmmeter to check for shorts and grounds in system wiring. **NOTE: This is a critical and necessary step for avoiding installation problems later.** When checking for shorts between shields, remember that the provided interconnection cable harnesses already have the shields connected together internally as a preparation to their introduction to the central equipment's ground.
- Step 6:** Set patient, staff and duty station addresses. Refer to Figure 23 in the **Equipment Configuration and Settings** section.
- Step 7:** Power up the equipment. When prompted, enter the Master ID at each NC304 and NC304LCD master station. Then at master station (ID #1), perform the **Restore System Defaults** function. When the system has returned to normal operation, it will be ready for use and programming. Refer to the **System Configuration and Programming** section for more information on these functions.
- Step 8:** Connect equipment to system wiring. **SEE TROUBLESHOOTING INFORMATION BELOW!**
- Step 9:** Verify connections.
- Step 10:** Perform full operational test of the system, including all peripheral devices.
- Step 11:** Read **System Configuration and Programming** section and configure system.
- Step 12:** Train system operators.

TIP: Before the above process begins, consider this brief comment on **troubleshooting**. The transition between **Step 9** and **Step 10** is a very important one. It is during this phase of the installation process that the system is first powered up with field wiring, patient stations and peripheral devices. This is the time when most installers encounter problems with wiring and equipment. To reduce troubleshooting time and prevent damage to the system components, the installer must take the following precautions:

- Do not connect the entire system together for initial power up. It is suggested that just the **central equipment** and the first **master station/VGA monitor** be connected for test. Next, the remaining master stations/VGA monitors must be connected one by one, until all are connected and functional. This allows the installer to establish a “known good” test point to work from, as well as immediately identifying problems as they are introduced to the system.
- Do not connect all **patient station** runs to the **central equipment** at once. Connect individual runs to the central equipment one by one until all are connected and functional. This allows the installer to more easily locate and recognize the introduction of wiring or equipment problems in the field.

These procedures may appear to take longer to perform than connecting the entire system together and powering it up, but following them reduces troubleshooting time markedly.

Part 2 – System Installation, Maintenance and Troubleshooting

System Installation

Problems to Avoid

- Do not use wire nuts for wire connections. Wire connections must be made with compression-type connectors, rated for stranded wire, that use a ratcheting-type tool for installation.
- Do not short shields together, as this allows for noise transference from the data lines to the audio lines.
- Unused conductors from the plug-on wiring harnesses of various devices must be taped up to prevent the ends of the cut wires from coming into contact with other points (circuit boards, back boxes, etc.).
- Do not exceed the maximum specified cable distances. Pay extra attention during the planning stages when running cable to areas that add “hidden” length to cable runs.
- The capacitance on the data wires is critical (<24 pF/ft.). If the cable capacitance exceeds this level, data signal degradation can occur and interfere with normal system operation.
- Do not run system cabling in close proximity to other electrical system cables or building power cables. These systems can induce noise, resulting in system operational problems and/or audio noise.

Equipment Descriptions, Requirements and Locations

Locate the Tek-CARE® NC300™II System Equipment in accordance with the following information. The installation of all system equipment, cabling and enclosures must be in accordance with the National Electrical Code (ANSI/NFPA 70-1999), the Healthcare Facilities Code (ANSI/NFPA 99-1999), and all applicable state and local codes.

NC351(A) and NC351(A)/2 Central Equipment (CE): The microprocessor-based NC351(A) is the core piece of equipment for the Tek-CARE® NC300™II Nurse Call System. All master stations and patient stations connect to it; patient stations and NC306 master stations receive their power from the central equipment, while NC304 and NC304LCD master stations operate from local +12 VDC power supplies. The standard NC351(A) will support 4 master stations (1 per port) and 256 patient stations (64 per port). The NC351(A)/2 will support 8 master stations and 512 patient stations, and includes the necessary additional connection ports. **NOTE: This configuration also requires the external PK305/A supplemental power supply. The NC351(A) and NC351(A)/2 central equipment can each power a maximum of 4 NC306 masters, or 3 NC306 masters with NC255 master station expanders. Any remaining system ports can be filled with NC304 and NC304LCD stations, if desired.** Both CE versions also include 2 isolated serial outputs for external applications (such as Tek-PAGING®, event printing and Tek-MMARS®II). All master and patient station ports are protected by self-resetting current-limiting circuits. Optional battery backup is provided using TekTone® PK250-series.

The NC351(A) or NC351(A)/2 includes a standard 3-prong connector and cable, and must be located near a dedicated 115 VAC outlet connected to the Emergency Branch of the facility’s Essential Electrical System (i.e., connected to a backup power source), suitable for computer-grade equipment. To minimize wiring distances, the device must be centrally located to the master and patient stations. The NC351(A) or NC351(A)/2 must be shelf or desk mounted in an area with a consistent temperature of approximately 26°C and relative humidity not exceeding 80%. If a PK250-series battery backup is used, locate it in the same area. A PK305/A Supplemental Power Supply is required with the NC351(A)/2 (as indicated above). Locate the PK305/A near a dedicated 115 VAC outlet connected to the facility’s Emergency Power Circuit (i.e., connected to a backup power source), suitable for computer-grade equipment, and within 2' of the NC351(A)/2. Interconnect the NC351(A)/2 and PK305/A using the provided interconnection cable (CT305). **The PK305/A must always be powered down when the central equipment is powered down. Do not stack equipment on top of the NC351(A),**

Part 2 – System Installation, Maintenance and Troubleshooting

System Installation

Equipment Descriptions, Requirements and Locations

continued

NC351(A)/2 or PK305/A. Do not locate these devices near other electrical systems, such as fire alarm panels, electrical motors, air conditioning equipment, etc.

PK304 Master Station Power Supply: The PK304 provides +12 VDC power to the NC304 or NC304LCD Master Station. It connects directly to the master station, and requires a dedicated 115 VAC wall outlet connected to the facility's Emergency Power Circuit (i.e., connected to a backup power source), suitable for computer-grade equipment (see **NC304, NC304LCD and NC306 Master Station**).

NC304, NC304LCD and NC306 Master Station: The NC304, NC304LCD or NC306 Master Station is used by the facility staff to interface with, configure and program the nurse call system via the function buttons and numeric keypad. It provides call indication on individual selector LEDs (NC306), a 2-line LCD display (NC304LCD), or works in conjunction with an NC313 VGA monitor (NC304 and NC304LCD) to display any or all system activity. The staff may answer calls via the loudspeaker (controlled by the "TALK" button) or by using the handset for calls that require more privacy.

The NC304, NC304LCD or NC306 is typically located on a desk or countertop, within easy reach of the facility staff. The NC304 and NC304LCD master stations must be located within 6' of a dedicated 115 VAC outlet connected to the Emergency Branch of the facility's Essential Electrical System (i.e., connected to a backup power source), suitable for computer-grade equipment. (See **PK304 Master Station Power Supply**.) The master station must also be within 6' of the included pre-wired wall plate, and it comes with a DB9 connector and cable for interconnection. **The pre-wired wall plate mounts on a single-gang ring or box, and must be within 1000' of the NC351(A) or NC351(A)/2 Central Equipment.** The operating environment for the master station is approximately 26°C and relative humidity not exceeding 80%. See wiring installation section for additional details. After all connections to the master station have been made, please use the included ty-wrap to secure all connected cables together for strain relief purposes. Battery backup is provided using TekTone® PK250-series. If a PK250-series is used, locate it in the same area.

NC315 LCD/NC313 VGA Monitor: The NC315/NC313 is used in conjunction with the NC304 or NC304LCD to display any or all system activity in standard English format. The 15" monitor displays up to 22 events simultaneously. This display is also required for system configuration and programming in conjunction with the master station. The NC315/NC313 includes standard on/off, brightness and contrast controls, and a power indicator.

The NC315/NC313 is typically located on a desk or countertop, within easy viewing range of the facility staff. The monitor must be within 6' of the NC304 or NC304LCD Master Station, and includes a DB15 connector and cable for interconnection. The monitor includes a standard 3-prong connector and cable, and must be within 6' of a standard 115 VAC computer-grade wall outlet. The operating environment for the NC315/NC313 is approximately 26°C and relative humidity not exceeding 80%. See **Wiring Installation** section for further details.

IR3xx-series Stations—General Information: All of the IR3xx-series devices' electronics are mounted on a flame-retardant ABS plastic panel. Nylon mounting screws are provided with all IR3xx-series stations to ensure compliance to the latest UL® 1069 requirements, which now include ESD testing. Users must observe **ESD precautions** when handling these devices as they may be *damaged* if improperly handled. Each of the IR3xx-series stations require a unique address, which is set using the on-board dipswitch (refer to **Equipment Configuration and Settings** section). Plug-on connectors are provided for easy installation.

The IR3xx-series stations use the Steel City H3BD backbox with a 3GC plaster ring. Refer to Figure 19 for mounting. The minimum dimensions for the backbox must be not less than 8.6" × 4.5" × 2.5", and the minimum clearance from current carrying parts to dead metal parts must be no less than 0.5". These devices are typically located for convenience, most commonly at the head of the patient's bed, unless specified otherwise. The IR3xx-series

Part 2 – System Installation, Maintenance and Troubleshooting

System Installation

Equipment Descriptions, Requirements and Locations *continued*

stations must be located within 1000' feet of the NC351(A) or NC351(A)/2, and so that furniture, curtains and other features do not interfere with audio communication. See **Wiring Diagrams** section for additional requirements. **NOTE: There are additional guidelines for station location in the wiring installation section.** The operating environment for the IR3xx-series stations is 10-40°C with relative humidity not exceeding 80%. See **Wiring Installation** section for additional information.

IR300-series Multipurpose Station: The IR300-series Multipurpose Station serves as an address point for stand-alone peripheral device applications. It has no external controls, but does have additional control connections brought out to an additional header (refer to **Figure 38—6 & 7-PIN Connector Outputs for IR3xx-series Stations**). Activate a special feature on the IR300-series station (only) by turning on dipswitch 7 to allow the device to operate its dome lamp outputs as zone lamps for zone annunciation.

The IR300-series must be located central to the various peripheral devices that are connected to it. See **IR3xx-series Station—General Information** for additional details.

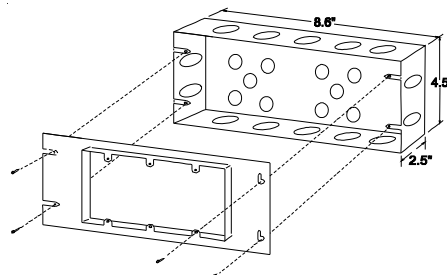

Figure 19 – Mounting IR Series Stations

IR019C Remote Speaker/Microphone Station: The IR019C is used in conjunction with the IR300-series station to provide a ceiling mounted or remotely mounted speaker/microphone. The IR019C is located where needed and mounts on a standard two-gang ring or backbox. The device must be located within 50' of the associated IR300-series station. The operating environment for the IR019C is 10-40°C with relative humidity not exceeding 80%.

IR301-series Single, IR302-series Dual Patient Stations: The IR301-series and IR302-series provide reliable hands-free communication between the patient and facility staff. The IR301-series and IR302-series use standard 0.25" phone jacks for call cord connection—one for the IR301-series and two for the IR302-series. Call cord presence is supervised, and the system provides an indication when a cord has been removed and not replaced. The patient stations have indicators for call placement assurance and in-use status. A reset button is also provided to reset calls locally. See **IR3xx-series Station—General Information** for additional details.

SF380-series Single Patient Stations: The SF380-series stations generate routine, cord-out and bath call placement signals in the same manner as the IR301-series, but they mount on single-gang boxes. The stations accommodate either code and fire signals (SF380C); a nurse presence signal (SF380P); or bath, code and fire signals (SF380A); but do not handle aide presence or monitor signals. **Note: SF380-series stations must be programmed for Personal Attn. Priority Level.**

IR311-series Single, IR312-series Dual Patient Stations: The IR311-series and IR312-series are identical to the IR301-series and IR302-series, with the exception of the jack type and added pillow speaker function control lines. The jacks are 8P8C type—one for the IR311-series and two for the IR312-series. Additional headers are provided for specific pillow speaker-only connections—one for the IR311-series and two for the IR312-series (refer to **Figure 38—6 & 7-PIN Connector Outputs for IR3xx-series Stations**). These stations can interface with the PM311C/PM312C Intercom Modules and the PM321B/PM322B Lamp Control Modules. See **IR3xx-series Station—General Information** for additional details.

Part 2 – System Installation, Maintenance and Troubleshooting

System Installation

Equipment Descriptions, Requirements and Locations

continued

IR319-series Single, IR320-series Dual Patient Stations: The IR319-series and IR320-series are identical to the IR301-series and IR302-series, with the exception of the jack type and added pillow speaker function control lines. The jacks are DIN type—one for the IR319-series and two for the IR320-series. Additional headers are provided for specific pillow speaker-only connections—one for the IR319-series and two for the IR320-series (refer to **Figure 38—6 & 7-PIN Connector Outputs for IR3xx-series Stations**). These stations can interface with the PM311C/PM312C Intercom Modules and the PM321B/PM322B Lamp Control Modules. See **IR3xx-series Station—General Information** for additional details.

PM311C/PM312C Pillow Speaker Intercom Modules: The PM311C (for IR311-series or IR319-series) and PM312C (for IR312-series or IR320-series) modules connect to the patient station and allow the nurse call system audio to be redirected from the patient station to the pillow speaker connected to it. SF301PI series, SF301DIG, SF401DIG or SF41-series pillow speakers are required for this application. If the connected call cord or pillow speaker does not support this function, the audio reverts back to the patient station. The modules plug directly onto the back of patient stations and are subject to the same environmental requirements.

PM321B/PM322B Light Control Modules: The PM321B (for IR311-series or IR319-series) and PM322B (for IR312-series or IR320-series) modules allow SF301PL series, SF301DIG, SF401DIG or SF41-series pillow speakers to activate control relays that can be linked via dry contacts to control overhead and table lighting. The control relays are brought out on a separate header. (Refer to **Figure 36—PM321B/PM322B Lamp Module Wiring Diagram**.) **WARNING: Connect only Class 2, Power Limited circuits (in accordance with ANSI/NFPA 70, ANSI/NFPA 99 and ANSI/UL® 1069) to the PM321B or PM322B. If in doubt, contact the factory.** The modules plug directly onto the back of patient stations and are subject to the same environmental requirements.

RY350B Multi-Channel Relay: The RY350B provides for the selection of entertainment program sources by the patient, via TekTone® pillow speakers with radio button (“R” series, SF301DIG or SF401DIG) in conjunction with IR311-series, IR319-series, IR312-series or IR320-series patient stations. (IR312-series and IR320-series stations require two RY350B relays.) The device has six circuit positions and allows 4 radio channel inputs (the remaining two channels are reserved for the “off” position and the TV audio source). The RY350B electronics are mounted on a flame retardant ABS plastic panel. It uses the same housings as the IR3xx-series stations. The RY350B requires a separate +12 VDC power source (1.2 Watt per device). Locate the RY350B within 25' of the associated patient station, with access to the facility's radio audio cable lines. The environment for the RY350B is 10-40°C with relative humidity not exceeding 80%. Refer to **Figure 35—RY350B Wiring Diagram** for specific connection information. Refer to **IR3xx-series Station—General Information** for housing information.

RY351B Hill-Rom® SideCom® Adapter: The RY351B provides an interface for the Hill-Rom® SideCom® bed to the IR311-series, IR319-series, IR312-series (requires two RY351B) and IR320-series (requires two RY351B) patient stations. This enables the intercom, call placement indication, and in-use indication functions of the SideCom® bed to work with the nurse call system. The SideCom®'s lamp and lighting controls are connected to the lighting control system and do not need to interface with the nurse call system. The RY351B interface also detects the disconnection of the (low voltage) signaling cable from the wall receptacle and places a noncancellable call to the programmed nursing Master Station. The RY351B electronics are mounted on an aluminum bracket that can be used to mount the device on a Steel City two-gang backbox, part number 52171-1/2 and 3/4 with 52-C-13 single gang adapter ring. The RY351B must be within 6' of the patient station to which it is connected. The Hill-Rom® P376 series plug-in adapter must be installed within 10' of the RY351B. The operating environment for the RY351B is 10-40°C with relative humidity not exceeding 80%.

Part 2 – System Installation, Maintenance and Troubleshooting

System Installation

Equipment Descriptions, Requirements and Locations *continued*

IR310-series Staff Station: The IR310-series provides a communication point for staff members to call the master station for staff to staff communication. The device also has a special feature that is activated by turning on dipswitch 7. This feature allows the device to call in as a patient station for applications in which call cords are not desired for patient call in. A call button, reset button, call-placed indicator and in-use status indicator are provided. See **IR3xx-series Station—General Information** for additional details.

IR315-series Duty Station: The IR315-series is similar to the IR310-series, but provides the extra feature of call annunciation and zone lamp operation. The IR315-series has no dipswitch 7 features. It is designed to provide additional points of annunciation for the nurse call system in locations that are not within sight or hearing of the master station. A call button, reset button, call-placed indicator, in-use status indicator and emergency indicator are provided. See **IR3xx-series Station—General Information** for additional details. The IR315-series does not support code call devices.

Call Cords:

SF301	Push button call cord, 7' (for IR301-series, IR302-series)
SF301/10	Same as SF301, but with 10' cord
SF301DIG	Pillow speaker, 8' cord, intercom & controls for lights, TV and radio (for IR311-series with PM311C, PM321 and RY350B; IR312-series with PM312C, PM322B and two RY350B)
SF301P Series	Pillow speaker with 7' cord (for IR311-series, IR312-series)
SF301PI Series	Pillow speaker with intercom, 7' cord (for IR311-series with PM311C; IR312-series with PM312C)
SF302	Dual push button call cord, 7' (for IR301-series, IR302-series)
SF302/10	Same as SF302, but with 10' cord
SF311	Push button call cord for 8P8C jack (for IR311-series, IR312-series)
SF312	Dual push button call cord for 8P8C jack (for IR311-series, IR312-series)
SF401	Push button call cord, 7' (for IR319-series, IR320-series)
SF401DIG	Pillow speaker, 8' cord, intercom & controls for lights, TV and radio (for IR311-series with PM311C, PM321 and RY350B; IR312-series with PM312C, PM322B and two RY350B)
SF401P Series	Pillow speaker with 7' cord (for IR319-series, IR320-series)
SF41-series	Pillow speaker, 8' cord, intercom & controls for lights and TV (for IR311-series with PM311C, PM321; IR312-series with PM312C, PM322B)

NOTE: Geriatric call cords are available with 0.25" phone plug and 8P8C plug, with either single and dual call buttons. Contact the factory for details.

Call cords are inserted into their associated patient stations and are subject to the same environmental requirements.

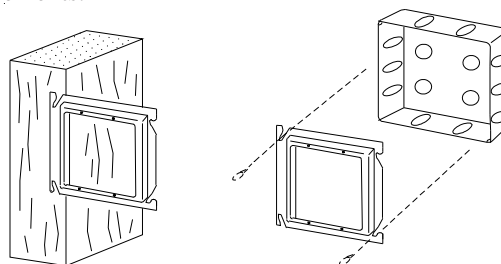

Figure 20 – Mounting LI380, LI384A, LI386-series Dome/Zone Lights

LI380 Dome Light: The LI380 provides visual indication from the IR3xx-series stations and associated peripheral devices. Four bulbs and four colored lenses allow the device to indicate all system call types with various flash rates and combinations. When connected to an IR315-

Part 2 – System Installation, Maintenance and Troubleshooting

System Installation

Equipment Descriptions, Requirements and Locations

continued

series Duty Station, the light functions as a zone light. The LI series dome lights use the Steel City H2BD backbox with a 2GC plaster ring; refer to Figure 20 for mounting. The minimum dimensions for the backbox must be not less than 4"×4"×1½", and the minimum clearance from current carrying parts to dead metal parts must be no less than 0.5". The dome light must be located above or beside the doorway of the associated room, and must be mounted so that unobstructed visibility is provided. When being used as a zone light, the LI380 must be mounted at corridor heads or junctions so that facility staff members can readily identify the associated zone area. The LI380 must be within 50' of the patient station it is connected to. **The LI380 requires a specific jumper connection to be made (from pin 1 of the 8-pin connector to pin 6 of the 15-pin connector on the associated patient station) to disable the lamp fault detection circuitry of the associated IR3xx-series station it is connected to** (refer to **Figure 31—IR3xx-series Connections to Peripheral Devices**). The operating environment for the LI380 is 10-40°C with relative humidity not exceeding 80%. See **Wiring Installation** section for additional details.

LI384A Supervised Dome Light: The LI384A provides the same functionality as the LI380 and includes supervisory circuitry to monitor the lamps. When a lamp fails, the system indicates a lamp fault for the associated room location. The wire jumper mentioned in the LI380 information is not required. See the **LI380 Dome Light** information for location and environmental requirements.

LI386-series Dome/Zone Light: The LI386-series provides the same indication functionality as the LI384A and includes support electronics to make it an addressable device. This device is suitable for stand-alone equipment applications and zone indication applications. **NOTE: This device does not support all of the standard peripheral devices** (refer to **Figure 33—LI386-series Dome/Zone Light Wiring Diagram**). Turning on dipswitch 7 activates the zone indication feature. See the **LI380 Dome Light** information for location and environmental requirements.

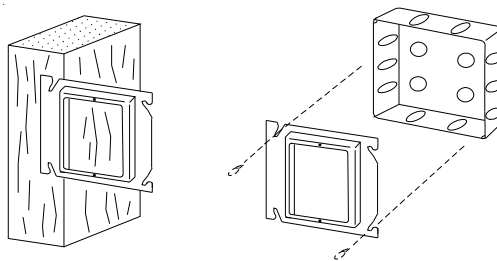

Figure 21 – Mounting SF Series Stations

SF Series Peripheral Devices—General Information: The SF series peripheral devices' electronics are mounted on flame retardant ABS plastic faceplates. SF series devices must be mounted within 50' of the patient station to which it will be connected. They are mounted on single-gang rings or boxes; see Figure 21 (minimum ring opening not to be less than 1¾" × 2¾"). Nylon mounting screws are provided with all SF series peripheral devices to ensure compliance to the latest UL® 1069 requirements, which now include ESD testing. The minimum clearance from current carrying parts to dead metal parts must be no less than 0.5". Plug-on connectors are provided for easy installation. See **Wiring Installation** section for additional details.

SF337C Bath/Emergency Switch: The SF337C allows patients to initiate a bath call to inform staff members that they require assistance in bathroom or restroom areas. The device is designed to be mounted in wet areas when properly installed (using the included gaskets for the panel and screws). The device can be activated by hand with the red pull down lever, or by pull-cord (if installed). It also provides a call placed indicator.

Part 2 – System Installation, Maintenance and Troubleshooting

System Installation

Equipment Descriptions, Requirements and Locations *continued*

This device is typically located in toilet, bath and shower areas, and is mounted at a height convenient for use. If the device is being mounted to a tile wall or other irregular surface, the installer must provide extra sealant to fill tile seam points or other gaps. If the device is being used with pull-cord activation, the included cord must be installed through the guide tab and red pull-down lever and secured with a double knot. Mounting location and cord length must be such that a prone patient can reach the call cord to activate the device. The operating environment for the SF337C is 10-40°C, and the device is water resistant when correctly installed. See **SF series Peripheral Devices—General Information** for additional details.

SF340B Emergency Switch: The SF340B provides the same operational functionality as the SF337C, except that it is not suitable for moist or wet environments. The operating environment for the SF340B is 10-40°C with relative humidity not exceeding 80%. See **SF series Peripheral Devices—General Information** for additional details.

SF381 Standalone Emergency Switch: The SF381 provides the same operational functionality as the SF337C, except that it is not suitable for moist or wet environments. The operating environment for the SF381 is 10-40°C with relative humidity not exceeding 80%. See **SF series Peripheral Devices—General Information** for additional details. The SF381 differs electronically from the SF337C or SF340B devices in that it incorporates electronic circuitry to support standalone functionality similar to that of an IR3xx-series Station. Information that applies to this aspect of the device can be found in the first paragraph of **IR3xx-series Stations—General Information**.

SF341B Supervised Code Call Station: The SF341B allows patients and staff members to initiate high priority “CODE” calls. The device incorporates a supervisory circuit to monitor the wiring connection to the patient station, as well as a call placed indicator. The device is activated by hand operation of the blue pull-down lever. The SF341B must be located for convenient operation in areas that require code call initiation (such as ICU/CCU areas). The environment for the SF341B is 10-40°C with relative humidity not exceeding 80%. See **SF series Peripheral Devices—General Information** for additional details.

SF382 Standalone Code Call Station: The SF382 provides the same operational functionality as the SF341B. The operating environment for the SF382 is 10-40°C with relative humidity not exceeding 80%. See **SF series Peripheral Devices—General Information** for additional details. The SF382 differs electronically from the SF341B device in that it incorporates electronic circuitry to support standalone functionality similar to that of an IR3xx-series Station. Information that applies to this aspect of the device can be found in the first paragraph of **IR3xx-series Stations—General Information**.

SF350B Nurse/Aide Presence Station: The SF350B works in conjunction with the nurse/aide presence registration features of the nurse call system. It allows nurse and aide staff to register their presence with a simple button push, and facilitates the transfer of nurse follower features from room to room (when activated at the master station). A nurse registration button and indicator, and an aide registration button and indicator are provided. The SF350B must be located for staff convenience, typically within the associated room near its entrance. The environment for the SF350B is 10-40°C with relative humidity not exceeding 80%. See **SF series Peripheral Devices—General Information** for additional details.

SF250 Staff Presence Station: The SF250 functions in the same manner as the nurse portion of the SF350B. This device is labeled “Staff” instead of “Nurse,” and has the same location and environmental requirements as the SF350B. See **SF series Peripheral Devices—General Information** for additional details.

Part 2 – System Installation, Maintenance and Troubleshooting

System Installation

Wiring Installation

The bulk of the necessary wiring information can be found in the **Wiring Diagrams** section at the end of this manual. Refer to **Figure 25—Tek-CARE® NC300™ II Block Wiring Diagram** for additional cable specifications. Below is a list of important wiring installation items critical to a successful installation, and a list of problems to avoid.

The NC351(A) and NC351(A)/2 include master station ports, patient station ports and serial ports. Interconnection cable harnesses (also known as “whip” or “pigtail” connectors) are provided for the master station ports (with each master station) and for the patient station ports (4 for NC351(A) and 8 for NC351(A)/2 are provided with the central equipment). For the serial ports, a single serial cable, configured for the NC365A Radio Paging System (as indicated in **Figure 39—NC351(A) Serial Connection Diagram**), is included. Each port type is separately described below, with the specifics of connection.

Each **Master Station Port** supports one master station and a maximum of 1000' of interconnecting cable (refer to **Figure 25—Tek-CARE® NC300™ II Block Wiring Diagram**, **Figure 26—Tek-CARE® NC300™ II System Connection Diagram**, and **Figure 27—NC304/NC306 Block Wiring Diagram**). Master stations must be home run to the central equipment. This is the wiring specification for the interconnecting cable:

- Data Wires:** #18 AWG, 1 twisted pair (8 twists per ft.) plus 1 conductor (3 conductors, 7 str. BC) with 100% aluminum/mylar shield and #20 AWG TC drain wire. Nominal insulation 0.017", nominal OD 0.245" and capacitance <24pF/ft. Recommended conductor colors are ORANGE, YELLOW and GREEN. Overall jacket.
- Power Wires:** #18 AWG, 3 conductors (7 str. BC) with 100% aluminum/mylar shield and #20 AWG TC drain wire. Nominal insulation 0.009" and nominal OD 0.175". Recommended conductor colors are BROWN, RED and BLUE. Overall jacket.
- Audio Wires:** #18 AWG, 1 twisted pair (8 twists per foot, 2 conductors, 7 str. BC) with 100% aluminum/mylar #20 AWG TC drain wire. Nominal insulation 0.017", nominal OD 0.235" and capacitance <24 pF/ft. Recommended conductor colors are VIOLET and GRAY. Overall jacket.
- Ground Wire:** #16 AWG, 1 conductor (26 str. BC) with nominal OD 0.101". Recommended color is BLACK.

Each **Patient Station Port** supports up to 64 patient stations and a maximum of 1000' feet of interconnecting cable. This maximum distance does not include peripheral wiring connections, and only reflects the common wiring between all of the stations on that particular port and their associated connection to the NC351(A) or NC351(A)/2 Central Equipment. The common wiring used is the same type as specified above for the master station connection. The following must be observed for patient station wiring:

- Each cable run must have no more than 16 patient stations, each with a 4-bulb dome lamp. Multiple runs to a single port are allowed, as long as the total 1000' maximum cable run per port is not exceeded. For example, if 64 stations, each having a 4-bulb dome lamp, are placed on a single port, there must be a minimum of 4 runs, and the total cable length of all the runs on the port must not exceed 1000'.
- Cable runs may have up to 32 stations if no dome lamps are used or if single or dual bulb dome lamps are used.
- Do not run cables to the bottom of the patient station backboxes, because there is no access for cable passage.

Part 2 – System Installation, Maintenance and Troubleshooting

System Installation

Wiring Installation

continued

- At all splice points, the common cable shields must be kept isolated from all other circuits and fed through as any other conductor would be. The shields must be continuous through the entire run and must be isolated and taped back at the end of the run. When connecting the common cable to the central equipment, the shields will be connected to the shields of the interconnecting wire harness (also known as “whip” or “pigtail” connector).
- Each patient station port has one audio path. If a system is known to have a small quantity of stations that will occupy only one or two ports, the installer should consider redistributing the devices evenly among all of the available station ports. This enables all of the available audio paths for use in system operation, allowing four or eight (depending on the central equipment used) simultaneous paths, and increasing call response efficiency.

Equipment Configuration and Settings

Each isolated **Serial Port** provides an RS232 output (8 data bits, no parity and 1 stop bit) at 9600 baud. Various connection configurations are shown on **Figure 39—NC351(A) Serial Connection Diagram**. Standard #22 AWG, 4 conductor cable will support all indicated applications. Devices connected to these outputs must be within 100' of the NC351(A) or NC351(A)/2.

NC304 and NC304LCD Master Station: The device addresses are configured through software. Please see the **System Configuration and Programming** section in **Part 1** of this manual for set up information. Internal adjustment controls are provided for field adjustment of **Audio In** (clockwise to adjust louder), **Tone Level** (clockwise to adjust louder), and **Audio Out** (counterclockwise to adjust louder), if the site has specific needs that require changes from the factory settings. The **Audio Out** control must never be set to less than the half position. If the master audio is too loud at the patient station, refer to **Figure 40—NC351(A)/2 Internal Hardware Diagram** for additional controls to adjust. A reset switch is present and is located on the bottom of the master station and is accessible by one of the openings there. It is a momentary microswitch that can be pressed by any small nonmetallic tool. Pressing this switch will reset the master station. Refer to Figure 22 for physical locations of adjustment potentiometers.

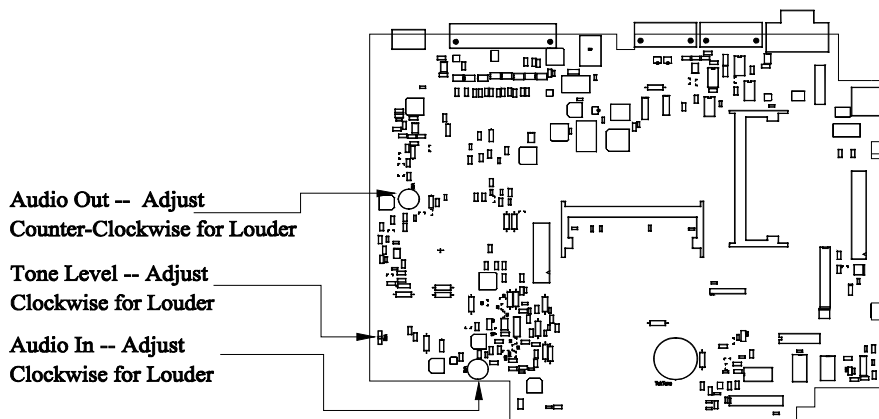

Figure 22 – NC304 and NC304LCD Potentiometer Functions

Part 2 – System Installation, Maintenance and Troubleshooting

System Installation

Equipment Configuration and Settings

continued

NC306 Master Station: The device address is configured via dipswitches on the back of the master. Refer to Figure 22a for switch settings. Internal adjustment controls are provided for field adjustment of **Audio In** (clockwise to adjust louder), **Tone Level** (counterclockwise to adjust louder), and **Audio Out** (counterclockwise to adjust louder), if the site has specific needs that require changes from the factory settings. The **Audio Out** control must never be set to less than the half position. If the master audio is too loud at the patient station, refer to **Figure 40—NC351(A)/2 Internal Hardware Diagram** for additional controls to adjust. A reset switch is located on the back of the master station. Toggling this switch will reset the master station. Refer to Figure 22b for locations of adjustment potentiometers.

A maximum of four NC306 Masters or three NC306 Masters with NC255 Expanders can be connected to the NC351(A) or NC351(A)/2 Central Equipment.

NC351(A) or NC351(A)/2 Central Equipment: These devices are entirely configured through software. **NOTE:** the installer must perform **Restore System Defaults** from the **System Functions** menu prior to performing any kind of system configuration or programming (refer to **System Operating Instructions** for details).

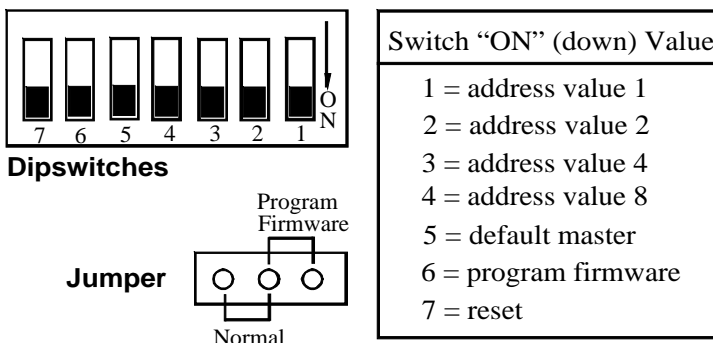

Figure 22a – NC306 Dipswitches and Jumper Settings

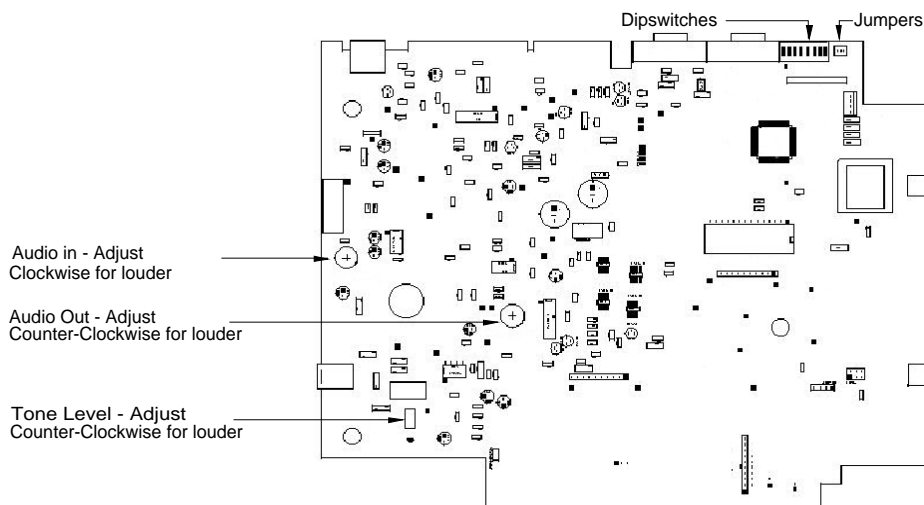

Figure 22b – NC306 Potentiometer Functions

Part 2 – System Installation, Maintenance and Troubleshooting

System Installation

Equipment Configuration and Settings

continued

IR3xx-series Stations: These devices are addressed by turning on and off the 7 available dipswitches located on each device. Stations that occupy the same port must all have unique addresses (ranging from 00 to 63). The 7-switch dipswitch uses a binary configuration method (1 has a value of 1, 2 a value of 2, 3 a value of 4, 4 a value of 8, etc.). Using these values, the station address is represented by the sum of the values of all switches that are turned on. For example, if switches 2 (value 2) and 5 (value 16) are turned on, the address is 18 (2+16=18). Using this method, values of 00 to 63 can be generated using only switches 1 through 6. This leaves dipswitch 7 free for special features as described in the **Equipment Descriptions, Requirements and Location** section. See Figure 23 for reference.

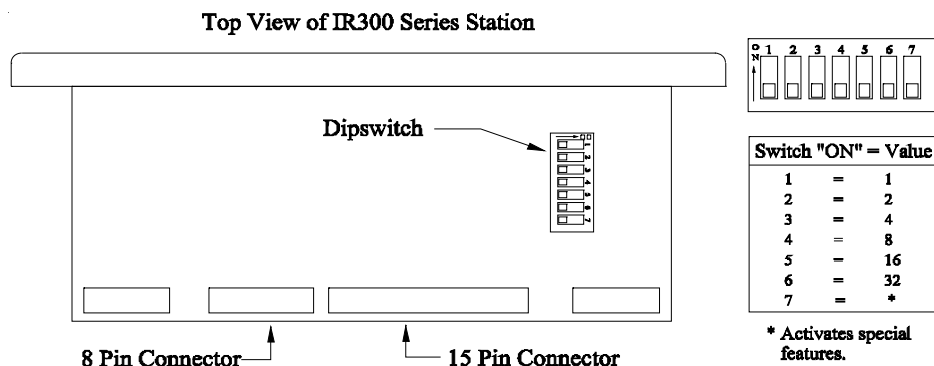

Figure 23 – IR3xx-series Stations Dipswitch Location and Switch Values

The system uses this information and the port that a station is plugged into to create its **default station number**. The default station number consists of four digits. The first digit is 0 and is assigned by the software. The next digit is the port that the device is plugged into (ranging from 1 to 8). The final two digits are the station address, based on the dipswitch setting on the actual device. For example, a station with a dipswitch address value of 18 (from the previous example) that is plugged into station port 4 of the central equipment has an address of: 0418 (0 is assigned, port 4, dipswitch value of 18).

IR315-series Duty Station: In addition to the dipswitch address settings, the IR315-series also has a tone control adjustment (via three pin header) to set annunciation tone levels. Refer to Figure 24 for header settings.

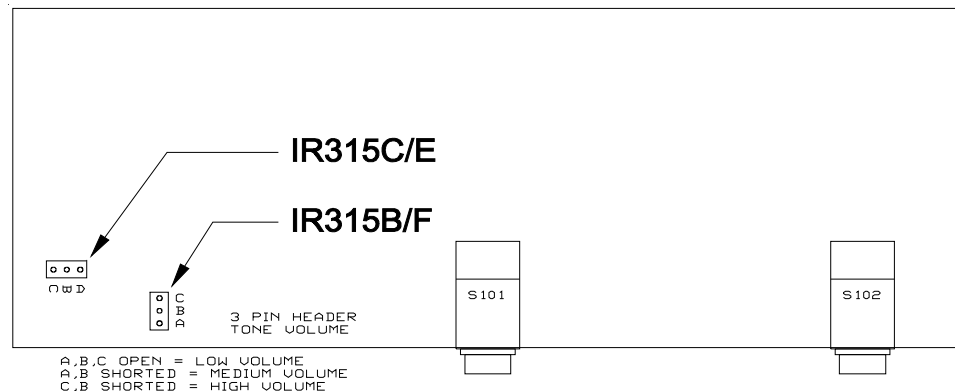

Figure 24 – IR315-series Duty Station Layout

Part 2 – System Installation, Maintenance and Troubleshooting

System Installation

Equipment Configuration and Settings

continued

SF380A Single Patient Station:

Refer to **Figure 47—SF380A Wiring Diagram** for dipswitch settings. **Note:** SF380-series stations must be programmed for Personal Attn. Priority Level.

SF380C Single Patient Station:

Refer to **Figure 43—SF380C Connections to Peripheral Devices** for dipswitch settings. **Note:** SF380-series stations must be programmed for Personal Attn. Priority Level.

SF380P Single Patient Station:

Refer to **Figure 44—SF380P Connections to Peripheral Devices** for dipswitch settings. **Note:** SF380-series stations must be programmed for Personal Attn. Priority Level.

SF381 Standalone Bath Station/SF382 Standalone Code Station: Refer to **Figure 45—SF381/SF382 Wiring Diagram** for dipswitch and jumper (shunt) settings.

PM352 Station Port Card:

Refer to **Figure 42—PM352 and PM354 Jumper Settings** for jumper settings.

PM353 Processor Card:

There are two sets of dipswitches on this card. During normal usage, these switches should not need to be changed from the factory settings. Refer to **Figure 40—NC351(A)/2 Internal Hardware Diagram**. The dipswitch functions are as follows:

Vertical Dipswitch:

- 1 – Reset Polling Processor.
- 2 – Normally off. If turned on during a power up, the system will perform the **Detect System Stations** menu function (see **System Configuration and Programming** section).
- 3 – Normally off. If turned on, enables Bed Out call for test purposes.
- 4 – Off, no function.
- 5 – Normally off.
- 6 – Off, no function.
- 7 – Off, no function.

Horizontal Dipswitch:

- 1 – Reset Central Processor.
- 2 – Normally off. If turned on during a power up, the system will perform the **Restore System Defaults** menu function (see **System Configuration and Programming** section).
- 3 – Normally off. Turn on if NC364A Telephone Interface is connected to the system.
- 4 – Normally off. If turned on before booting, it allows the system to run with no masters. Operation will be slower, and masters will be detected as they are connected.
- 5 – Normally off. Turn on to support Versus® system.
- 6 – Off, **do not change**.
- 7 – Off, **do not change**.

PM354 Master Port Card:

Refer to **Figure 42—PM352 and PM354 Jumper Settings** for jumper settings.

Part 2 – System Installation, Maintenance and Troubleshooting

System Test Instructions

This section provides guidelines for testing the Tek-CARE® NC300™ II system. As mentioned previously, we recommend that the installer connect and test the system in sections, to allow for easier identification of problem locations. Before testing a system, perform a complete walk through of the facility, and be certain to:

- verify that all components of the system to be tested are completely installed.
- verify that all patient stations that require them have call cords attached.
- verify that all pull cord or hand pull stations are in the “Reset” position.

Using the **System Operating Instructions** section for reference, activate and observe the system operation for every component connected to the system. While initial testing must be performed in sections, a complete system test must be performed once all components are connected to the system. This entails activating every system component and verifying its operation a final time before considering the installation complete.

We recommend that the system be periodically tested as indicated in the **System Test Instructions** to verify that the system is in good operating condition. If problems are encountered, contact qualified service personnel for system repair or maintenance. The next section, **System Maintenance Instructions**, indicates which items may be serviced by on-site maintenance personnel.

Part 2 – System Installation, Maintenance and Troubleshooting

System Maintenance Instructions

NOTE: Certain maintenance and upgrade operations require the nurse call system to be deactivated. Facility staff must be notified before system deactivation and given an estimated length of time that the system will be off.

NC304, NC304LCD or NC306 Master Station: The handset must be replaced if a problem is encountered. To do so, perform the following steps:

- To remove the handset from the cord, depress the modular jack's locking tab and pull the cord away from the handset. This should occur easily if the locking tab is properly depressed.
- Insert the cord into a new handset. Gently pull on the cord to ensure that the locking tab is engaged and the cord does not pull out.
- Test the new handset by placing a call to a patient station, using the handset for communication (refer to **System Operating Instructions** for details).

The handset cord may also be replaced if a problem is encountered. To do so, perform the following steps:

- To remove the handset from the cord, depress the modular jack's locking tab and pull the cord away from the handset. This should occur easily if the locking tab is properly depressed.
- To remove the cord from the master station base, depress the modular jack's locking tab and then pull cord away from the master station base. This should occur easily if the locking tab is properly depressed.
- Insert the new cord into the handset. Gently pull on the cord to ensure that the locking tab is engaged and the cord does not pull out.
- Insert the new cord into the master station base. Gently pull on the cord to ensure that the locking tab is engaged and the cord does not pull out.

NC351(A) or NC351(A)/2: The FZ011 fuse (4A, 250 VAC – 0.25" × 1.25") in the power entry module may be replaced. Refer to drawing 3001 for power entry module location.

- Turn off the central equipment and disconnect the 115 VAC power plug. **WARNING: Failure to disconnect the 115 VAC power prior to replacing the fuse could result in a dangerous shock!**
- Using a small slotted screwdriver, remove the fuse plate from the power entry module.
- Remove the old fuse from the holder and insert a new fuse.
- Reinsert the fuse plate into the power entry module.
- Reconnect power to the central equipment.

IR301-series, IR302-series, IR319-series, IR320-series or SF380-series Patient Station:

Call cords may be replaced if a problem is encountered. To do so perform the following steps:

- To remove the call cord, firmly grip the plug and pull straight away from the patient station.
- To insert the new call cord, hold the plug and push the end straight into the call cord jack on the patient station.
- Test the cord by pressing the button on the other end. This should initiate a call and light the call indicator. Press the reset button on the patient station to reset the call. Observe the station for 10 seconds to ensure that no "cord-out" call occurs.

IR311-series or IR312-series Patient Station: Call cords and/or pillow speakers may be replaced if a problem is encountered. To do so perform the following steps:

- To remove the call cord or pillow speaker, firmly grip the plug and depress the locking tab. Pull straight away from the patient station.
- To insert the new call cord or pillow speaker, hold the plug and push the end straight onto the call cord jack on the patient station.
- Test the call cord or pillow speaker, respectively, by depressing the button on the other end or the red nurse call button. This should initiate a call and light the call

Part 2 – System Installation, Maintenance and Troubleshooting

System Maintenance Instructions

indicator. Press the reset button on the patient station to reset the call. Observe the station for 10 seconds to ensure that a “cord-out” call does not occur.

LI380, LI384A and LI386-series Dome/Zone Lights: Lamp bulbs must be replaced if they no longer light. To do so, perform the following steps:

- Remove the light cover lens by gripping it firmly, squeezing the sides and pulling it straight off the base plate.
- Remove the bulb by grasping the glass portion gently, so as not to break it. Push inwards, rotate it counterclockwise, and pull it straight away from the metal socket.
- If a color bulb cover is used, remove and transfer it to the new bulb.
- Hold the new bulb by the glass portion gently, so as not to break it. Push it straight into the new socket and rotate it clockwise.
- Replace the cover lens.
- Test the lamps by triggering the appropriate call to illuminate the new bulb (refer to the **System Operation Instructions** for details).

PK305/A Supplemental Power Supply Upgrade: **NOTE:** This component must only be added if the system is being upgraded with a PM352 Station Port Card (see **PM352 Station Port Card Upgrade** section). This component is always used with the NC351(A)/2 Central Equipment, which includes two PM352 cards as a standard feature.

- Connect power interconnect cable, provided with the PK305/A unit, to the PK305/A and the NC351(A) (refer to **Figure 40—NC351(A)/2 Internal Hardware Diagram** for connection points).
- Connect the provided 120 VAC power cord to the PK305/A and plug into a 120 VAC outlet.
- Turn the PK305/A on. **This device must always be powered down when the central equipment is powered down.**

PM352 Station Port Card Upgrade: TekTone® recommends unit be sent to factory for PM352 upgrade. TekTone® assumes no responsibility for damage caused by improper connections made in the field. **NOTE:** This component requires that a PK305/A Supplemental Power Supply be connected to the central equipment device. This upgrade allows the central equipment to support an additional 256 patient stations. Configure the jumpers on the card properly as shown in **Figure 42—PM352 and PM354 Jumper Settings**.

- Turn off the NC351(A) Central Equipment.
- Remove 4 screws and remove the central equipment chassis cover.
- Refer to **Figure 40—NC351(A)/2 Internal Hardware Diagram** for card location and orientation.
- Remove two cover plates and retain mounting bolts.
- Refer to **Figure 41—NC351(A)/2 Expanded System Exploded Internal Wiring Diagram** for proper connection of CT351 and CT367s.
- Insert card into appropriate motherboard slot. Verify that card is seated properly.
- Use mounting bolts to secure card brackets to the central equipment chassis.
- Install PK305/A as described above in **PK305/A Supplemental Power Supply Upgrade**.
- Reinstall central equipment cover.
- Power up the system and use existing field port cable connections to verify that card is operating normally, prior to connecting unverified field port cables.

PM354 Master Port Card Upgrade: TekTone® recommends unit be sent to factory for PM354 upgrade. TekTone® assumes no responsibility for damage caused by improper connections made in the field. **NOTE:** This component requires that a PK305/A Supplemental Power Supply be connected to the central equipment device. This upgrade enables the central equipment to support an additional 4 master stations. Configure the jumpers on the card properly as shown in **Figure 42—PM352 and PM354 Jumper Settings**.

Part 2 – System Installation, Maintenance and Troubleshooting

System Maintenance Instructions

- Turn off the NC351(A) Central Equipment.
- Remove 4 screws and remove the central equipment chassis cover.
- Refer to **Figure 40—NC351(A)/2 Internal Hardware Diagram** for card location and orientation.
- Remove two cover plates and retain mounting bolts.
- Refer to **Figure 41—NC351(A)/2 Expanded System Exploded Internal Wiring Diagram** for proper connection of CT351, CT354s and CT370s.
- Insert card into appropriate motherboard slot. Verify that card is seated properly.
- Use mounting bolts to secure card brackets to the central equipment chassis.
- Install PK305/A as described above in **PK305/A Supplemental Power Supply Upgrade**.
- Reinstall central equipment cover.
- Power up the system and connect new master stations to additional ports. It is recommended that the new master stations be connected locally to the central equipment first to verify the card's operation prior to connecting new field cable runs and installing masters at their respective remote locations.

Replacement Part Numbers:

<i>Part #</i>	<i>Description</i>	<i>Used by</i>
CA033	Handset Cord	NC304 or NC304LCD Master Station
FZ011	4A 250 VAC – 0.25"×1.25"	NC351(A) or NC351(A)/2 CE
LI028	28v lamp	LI380, LI384A, LI386-series Dome/Zone lights
SF301	Call Cord – 7'	IR301-series, IR302-series Stations
SF302	Dual Call Cord – 7'	IR301-series, IR302-series Stations
SF301/10	Call Cord – 10'	IR301-series, IR302-series Stations
SF302/10	Dual Call Cord – 10'	IR301-series, IR302-series Stations
SF301DIG	Pillow Speaker (intercom, TV, radio and lights)	IR311-series, IR312-series Stations
SF301P	Pillow Speaker	IR311-series, IR312-series Stations
SF301PIR	Pillow Speaker (intercom and radio features)	IR311-series, IR312-series Stations
SF311	Call Cord – 7'	IR311-series, IR312-series Stations
SF312	Dual Call Cord – 7'	IR311-series, IR312-series Stations
SF311/10	Call Cord – 10'	IR311-series, IR312-series Stations
SF401	Call Cord – 7'	IR319-series, IR320-series Stations
SF401DIG	Pillow Speaker (intercom, TV, radio and lights)	IR319-series, IR320-series Stations
SF41-series	Pillow Speaker (intercom, TV and lights)	IR319-series, IR320-series Stations
SF401P	Pillow Speaker	IR319-series, IR320-series Stations
SF401P2L	Pillow Speaker	IR319-series, IR320-series Stations
TA030	Handset	NC304 or NC304LCD Master Station

Upgrade Part Numbers:

<i>Part #</i>	<i>Description</i>	<i>Used by</i>
PK305/A	Supplemental Power Supply	NC351(A)*
PM352	Station Port Card	NC351(A)*
PM354	Master Port Card	NC351(A)*

Contact Factory for software upgrade information and refer to the **Keyboard Functions** section of **Part 1, System Configuration and Programming**.

*NC351(A)/2 already includes two PM352 and PM354 cards. NC351(A)/2 always requires PK305/A.

Part 2 – System Installation, Maintenance and Troubleshooting

System Troubleshooting Guide

This section provides guidelines for troubleshooting the Tek-CARE® NC300™II system. It covers general troubleshooting practices, as well as specific suggestions for various problems.

As mentioned in the **System Installation** section of this manual, there are some general troubleshooting techniques that installation personnel must follow during the installation of the system equipment. **NOTE: Installers must always exercise care when troubleshooting problems that might involve high current or high voltage damage. Installers must also exercise extreme caution and be aware of equipment or wiring that uses or handles high voltage, as these sources are potentially lethal.**

Do not connect the entire system together for the initial power up. Connect only the **central equipment** and the first **master station/VGA monitor** for testing. Then connect the remaining master stations/VGA monitors one at a time until all are connected and functional. This allows the installer to establish a “known good” test point to work from, and to immediately identify problems as they are introduced to the system.

Do not connect all **patient station** runs to the **central equipment** at one time. Connect individual runs to the central equipment one by one until all are connected and functional. This allows the installer to more easily locate and recognize the introduction of wiring or equipment problems in the field.

Direct Connection is a classic troubleshooting technique. If a problem is encountered, an installer may directly connect a master station or a patient station to the central equipment. If the problem ceases, then the source of trouble is located in the field (i.e., wiring or mounting related problems), whereas if the problem remains, it is equipment based. This can also be applied to patient station peripheral devices, which can be directly connected at the patient station location. While this is not an absolute test, it can provide a strong indication of where to look when troubleshooting.

Swap Testing is another well-known method of problem identification. If a problem is identified, an installer can interchange a known good piece of equipment into the location in question and move the device having problems to the location that the known good device previously occupied. **NOTE: If a device or wiring indicates high current or high voltage damage, this technique must be delayed until the source of the original problem is located. When swap testing is performed, the system must be powered down during the actual swapping process or damage may result. “Hot-swapping” is highly discouraged.** As an example, a patient station in one room that demonstrates a problem can be “swapped” with a station from another room that is known to be working acceptably. If the symptom follows the original problem device, the problem is equipment based. If the problem remains in the original location, a field problem is indicated (i.e., wiring or mounting related problems). This technique can be applied to master stations, master station control equipment, central equipment ports, etc.

The Tek-CARE® NC300™II also provides diagnostic menu functions to assist in troubleshooting. The **Extended Printing** function is very useful for tracking master menu activity when troubleshooting. The **Diagnostics** menu also provides several functions for troubleshooting. Refer to the **System Configuration and Programming** section for details.

System Event Logging

Connect a computer or laptop running MS Windows® HyperTerminal directly to the central equipment’s central event printing port, and connect an NC306 or NC304LCD master directly to the central equipment. With this setup, specifics on fault conditions and system activity are displayed on the computer screen in real time, making initial setup and troubleshooting easier.

Part 2 – System Installation, Maintenance and Troubleshooting

System Troubleshooting Guide

System Event Logging

continued

Components Required

- A personal or laptop computer with a serial port
- A terminal emulator program capable of logging text received via the serial port to a file.
- A standard DB9 null modem or *crossover* cable

Using a Generic Terminal Emulator Program

- Connect the computer serial port to the PM454 event logging port.
- Configure the terminal emulator for 9600 bits per second, 8 bit data, 1 stop bit and no parity. If flow control settings exist, set to no flow control.
- Connect, if the program requires it.
- Generate some system events to test the connection.
- Configure the terminal emulator to log events to a file.

Using Microsoft® HyperTerminal:

- Connect the computer serial port to the PM454 event logging port.
- Start HyperTerminal (Start | All Programs | Accessories | Communications | HyperTerminal).
- Throughout this procedure, disregard or cancel all warnings and requests for dialing information, since this information is not required to log system events.
- Type a name for the connection, choose an icon to represent it, and click **OK**.
- Select the desired COM port to in the *Connect using:* drop-down box, and click **OK**.
- Set the port settings as follows: Bits per second: 9600, Data bits: 8, Parity: none, Stop bits: 1, Flow control: none, and click **OK**. (If not automatically prompted for port settings, access them as follows: Verify that HyperTerminal indicates *Disconnected* in the lower left corner. Choose File | Properties, and click on **CONFIGURE**.)
- If HyperTerminal indicates *Disconnected* in the lower left corner, choose Call | Call to connect.
- Generate some system events to test the connection.
- To configure HyperTerminal to log events to a file, choose Transfer | Capture Text. Browse to or type a name for the desired text file, and click the **START** button.

Voltage Readings

The following readings can be taken using a standard voltage meter. All readings are taken using the system ground as a reference. **NOTE:** All readings below are approximations and must be used only as rough guidelines. This is due to the variables created by each job site, such as wire lengths, number of stations, etc.

Master Station Connections: Taken with the master station connected at the wall plate or central equipment.

<u>Wire Color</u>	<u>Description</u>	<u>Voltage Reading</u>
Gray	Audio A	+5.5 to 6.5 VDC
Yellow	485B	0 to +5 VDC fluctuation
Orange	485A	0 to +5 VDC fluctuation
Blue	VOX	0 or +11 VDC (dependent on VOX circuit state)
Green	Ground	0VDC
Violet	Audio B	+5.5 to 6.5 VDC
Brown	Not used	
Red	+12 VDC	+10.5 to 12 VDC @ wall jack (dependent on wire run length)
Shields	Ground	0VDC

Patient Station Connections: Refer to **Figure 30—Connector Circuit Interconnections for Addressable Stations**, **Figure 31—IR3xx-series Connections to Peripheral Devices**, and **Figure 32—IR3xx-series Connections with Supervised Dome Light**.

Part 2 – System Installation, Maintenance and Troubleshooting

System Troubleshooting Guide

Voltage Readings

continued

Common Connector:

<u>Wire Color</u>	<u>Description</u>	<u>Voltage Reading</u>
Gray	Audio -	The levels on this line can vary, but must not be a constant +12 or +24 VDC.
Violet	Audio +	The levels on this line can vary, but must not be a constant +12 or +24 VDC.
Blue	+12 VDC	+11 to 12 VDC.
Green	Data Common	0 VDC.
Yellow	Data Out	See information below.
Orange	Data In	See information below.
Red	Negative	0 VDC.
Brown	+24 VDC	+24 VDC.

Yellow Data Out—To calculate the average voltage for this line, subtract the total number of patient stations connected to a port from 132. Divide the result by 126, then multiply by 12. For example, 10 patient stations would be: $((132 - 10) \div 126) \times 12 = 11.62$ VDC.

$$\text{Yellow wire's average voltage level (VDC)} = ((132 - P) \div 126) \times 12 \text{ VDC}$$

where P = the number of patient stations on the port.

Orange Data In—To calculate the average voltage for this line, add 186 to the total number of patient stations connected to a port. Divide the result by 442, then multiply by 12. For example, 10 patient stations would be: $((10 + 186) \div 442) \times 12 = 5.32$ VDC.

$$\text{Orange wire's average voltage level (VDC)} = ((P + 186) \div 442) \times 12 \text{ VDC}$$

where P = the number of patient stations on the port.

These formulas produce more accurate results if the nominal 12 VDC reading value is used instead of 12 VDC. Take the nominal 12 VDC reading from the *Blue* wire, using the *Red* wire as a reference. This number is also an approximation and may vary slightly from field tolerances.

Note: During CE power up stages, the data lines can be in standby or unknown states. This could result in a reading of approximately 12 VDC. Take readings for the yellow and orange wires when the system is in a running state after boot up is complete.

Peripheral Connector:

<u>Wire Color</u>	<u>Description</u>	<u>Voltage Reading/Test Suggestion</u>
Yellow/White	Aide Input	0 VDC / Momentary application of +12 VDC will toggle call status.
Green/White	Nurse Input	0 VDC / Momentary application of +12 VDC will toggle call status.
Orange/White	Bath Input	0 VDC / Constant application of +12 VDC will initiate bath call.
Red/White	Emergency Input	0 VDC / Constant application of +12 VDC will initiate emergency call.
Brown/White	Monitor Input	0 VDC / Momentary application of +12 VDC will initiate a Monitor call that is reset by pressing the reset button on the station. NOTE: A fire call can be triggered by applying a constant +12 VDC to both Red/White and Brown White at the same time.

Part 2 – System Installation, Maintenance and Troubleshooting

System Troubleshooting Guide

Voltage Readings

continued

<u>Wire Color</u>	<u>Description</u>	<u>Voltage Reading/Test Suggestion</u>
Black	Code A	Call active: +9 to 10 VDC. Call inactive: +12 VDC. This input works in conjunction with Code B. When this input is active, a trickle current runs constantly through the wires and code station with an approximate load of 47,000 ohms. Shorting these lines together will trigger a code call manually.
White	Code B	Call active: +7 to 8 VDC. Call inactive: +1 to 2 VDC. / See Black (Code A) information.
Gray	Negative	0 VDC.
Violet	+12 VDC	+11 to 12 VDC.
Blue	Lamp Fault	This input must receive a constant +24 VDC input, or a lamp fault will be triggered.
Green	Red Dome Output	+24 VDC when lamp is off and 0 to +1 VDC when lamp is on.
Yellow	Green Dome Output	+24 VDC when lamp is off and 0 to +1 VDC when lamp is on.
Orange	Yellow Dome Output	+24 VDC when lamp is off and 0 to +1 VDC when lamp is on.
Red	White Dome Output	+24 VDC when lamp is off and 0 to +1 VDC when lamp is on.
Brown	Peripheral LED Output	+1 to 2 VDC when no calls are active. A constant pulsing to +12 VDC when a bath or emergency call is placed.

Standalone Bath and Code Station Connections: Refer to **Figure 45—SF381/SF382 Wiring Diagram.**

Common Connector:

<u>Wire Color</u>	<u>Description</u>	<u>Voltage Reading</u>
Gray	Red Dome Output	+24 VDC when lamp is off; 0 to +1 when lamp is on.
Violet	White Dome Output	+24 VDC when lamp is off; 0 to +1 when lamp is on.
Blue	+12 VDC	+11 to 12 VDC.
Green	Data Common	0 VDC.
Yellow	Data Out	+8 to 11 VDC.
Orange	Data In	+4 to 6 VDC.
Red	Negative	0 VDC.
Brown	+24 VDC	+24 VDC.

Part 2 – System Installation, Maintenance and Troubleshooting

System Troubleshooting Guide

Symptoms and Suggestions

Code Fault Indication (SF341B)

- Confirm that the station actually has a code device connected to it.
- If a code station is present, then verify the trickle current loop path. Disconnect the Code A and Code B lines from the peripheral connector on the back of the patient station. Using an ohmmeter, read across the two lines for the loop resistance (approximately 47,000 ohms). Wiring continuity must also be verified.
- The code station and associated patient station can be swap tested with other “known-good” devices.

Comm. Fault Indication (patient station fault)

- Determine if the comm. fault is singular or a large group of patient stations. (If using NC306 Master Station, press the “ZONE” button twice to have master station indicate which points are in fault.)
- If the faults are a large group, then the associated common wiring to that section of rooms must be examined for opens, shorts and grounds. The actual architectural room numbers can assist in the physical location. If the faults represent all of the stations on the patient station port, then the port may no longer be working. Swap testing between ports can be performed. The installer will need to perform the **Detect System Stations** command from the **System Functions** menu (see **System Configuration and Programming** for details). Once the problem has been identified, corrected, and the ports returned to their original configuration, the **Detect System Stations** command will need to be executed again.
- If the fault is a single device, verify the local room wiring (connections and plug-on connector) for continuity, opens, shorts and grounds. The patient station may also be swap tested with another “known-good” device for verification.

Data or Polling Noise

- Verify that common cable shield drain wires have been kept isolated and fed through at splice points. At the end of a cable run, the shields must be isolated and taped back. Noise transference is a cumulative effect and is worsened for each error in connection. **NOTE:** The included connection harness (“pigtail” or “whip” connector) brings the shields together prior to entering the central equipment chassis. Thus, if an ohmmeter is used to check for continuity between shields, the connection harness must be removed prior to taking the reading.

IR019C has no audio communications

- Measure the speaker coil resistance with an ohmmeter. It must read approximately 45 ohms.
- Directly connect the IR019C to the associated IR300-series Multipurpose Station and verify function (refer to **Figure 38—6 & 7-PIN Connector Outputs for IR3xx-series Stations**). If it begins to operate, the interconnecting wire should be suspect. If it does not, then swap test the IR300-series station.

IR3xx-series Patient Station is not placing calls

- Swap test the associated call cord.
- Swap test the patient station with another “known-good” patient station.
- If the problem encompasses an entire port, see **Comm. Fault Indication** section of **System Troubleshooting Guide** for port swapping information.

IR3xx-series Patient Station has a constant “Cord Out” message

- Verify that the call cord is properly inserted.
- Swap test the call cord with another “known-good” call cord.
- Swap test the patient station with another “known-good” patient station.

Part 2 – System Installation, Maintenance and Troubleshooting

System Troubleshooting Guide

Symptoms and Suggestions

continued

IR3xx-series Patient Station that has been installed is not recognized by the system

- The installer will need to perform the **Detect System Stations** command from the **System Functions** menu (see **System Configuration and Programming** for details).

IR310-series Staff Station is placing “Routine Calls”

- The IR310-series station has a special “routine call” feature that is triggered by turning on dipswitch 7. If this feature is not desired, the dipswitch must be turned off. **NOTE:** This will effectively change the station’s address (triggering a comm. fault), so the **Detect System Stations** command must be run from the **System Functions** menu as per the **System Configuration and Programming** section to complete the change process.

IR315-series Duty Station or LI386-series Dome/Zone Lamp is not annunciating calls

- This is a software-controlled feature and is described in the **System Configuration and Programming** section. The duty station or dome zone lamp must have the same zones active as the zones that are to be annunciated by the device.

POLLING PROCESSOR FAIL indication

- This indicates that there has been a processor failure on the PM353 module within the NC351(A) or NC351(A)/2 Central Equipment.
- Reset the central equipment.
- Power down the system and re-seat all of the internal modules.

Lamp Fault Indication

- Determine the type of lamp being used with the station reporting the lamp fault (supervised or unsupervised).
- If the lamp is supervised, check the four bulbs for open filaments. This can also be verified by swap testing the bulbs with “known-good” bulbs. If all four bulbs are intact, verify the connection to the **Lamp Fault Input** (blue wire on the 15-pin peripheral connector on the associated patient station). During normal operation, the supervised dome lamp provides a steady +24 VDC input to prevent the lamp fault from being triggered. This ceases when a filament opens.
- If the lamp is unsupervised, check the connection from the **Lamp Fault Input** to the +24 VDC common wire. If this connection is present, verify its continuity. If the voltage is present, swap test the patient station with a “known-good” device.

LI380-series Lamp is not lighting

- Verify that the bulb filaments are not broken or open. This can also be verified by swap testing the bulb in question with a “known-good” lamp bulb.
- If the bulbs are functional, verify the connections to the patient station. The dome lamp may also be tested by directly connecting it to the patient station peripheral connector.
- The patient station may also be swap tested. Observe station circuit board for signs of high current damage.

MASTER FAILURE(S) indication

- Observe the number displayed with this message. This number represents the address of the master that is no longer communicating with the central equipment. This also represents the port that the master must be plugged into.
- Swap test the master station with another “known-good” master station. **NOTE:** Master stations are addressable—be sure correct address is set.
- Connect the master station directly to the CE.
- Verify master to central equipment connections.

Part 2 – System Installation, Maintenance and Troubleshooting

System Troubleshooting Guide

Symptoms and Suggestions

continued

NC304, NC304LCD or NC306 Master Station has no audio communications to all patient stations

- Check master station addressing and verify that the master is plugged into the correct port at the central equipment (i.e., the master that is addressed as 1 must be plugged into master port 1).

NC304 or NC304LCD Master Station is making a squealing noise and has erratic LED activity

- Make sure handset is hung up and hookswitch is depressed.
- Check to see if the master station's reset switch (switch #4 on the 4-position dipswitch) is ON. This is normally a factory setting and is not changed in the field. The normal operating position for this switch is OFF.

NC304, NC304LCD or NC306 Master Station is not displaying calls or is not handling calls as intended

- Perform **Restore Local Database** command from the **System Functions** menu (see **System Operation** section of this manual).
- Review programmed settings and data to verify information, especially master and station zone information (see **System Operation** section of this manual).

NC304LCD or NC313 Monitor is displaying incorrect call data

- Perform **Restore Local Database** command from the **System Functions** menu (see **System Operation** section of this manual).
- Review programmed settings and data to verify information (see **System Operation** section of this manual).

NC306 Talk LED continues to flash after CE has booted (CE LED flashing)

This indicates one of these two states:

- The system has not detected the presence of patient stations.
- The NC306 master station is not receiving a "master map" communication from the NC351(A) series CE. This may indicate a connection problem between the master station and the CE. Connect the NC306 master station directly to the CE for further direct testing.

NC315/NC313 Monitor is not displaying VGA signal

- Verify that the monitor is turned on.
- Verify that the VGA monitor is connected to a live 115 VAC computer grade outlet.
- Verify that the VGA cable from the monitor is plugged into the NC304 Master Station VGA Port.

NC315/NC313 Monitor power indicator is amber

- This indicator turns from green to amber when there is no video signal in. Check the video signal source and connections.

NC351(A) or NC351(A)/2 Central Equipment makes a loud buzzing noise shortly after power up (internal relay is chattering)

- Power NC351(A) or NC351(A)/2 down.
- Check for +12 VDC line in the field wiring for a ground short.

Part 2 – System Installation, Maintenance and Troubleshooting

System Troubleshooting Guide

Symptoms and Suggestions

continued

Pillow Speaker Intercom is not working and audio is coming from the patient station

- Verify that the pillow speaker is an SF301PI series, SF401PI series, SF401P2L, SF301DIG, SF401DIG or SF41-series device.
- Verify that the pillow speaker is properly inserted into the associated 8P8C or DIN jack. Also check the pins inside the jack for signs of bending that might prevent all connections from being made.
- Try the pillow speaker in another room that is known to be working correctly.
- Remove the patient station from the wall and verify that a PM311C or PM312C (for IR311-series, IR312-series, IR319-series or IR320-series) has been installed on the patient station. If a PM311C or PM312C module is present, verify the seating of the module and the plug-on connector seating.
- Swap test the PM311C or PM312C module with a “known-good” module.
- Swap test the patient station with another “known-good” patient station.

CENTRAL PROCESSOR FAIL indication at a single master location

NOTE: If the indication is system-wide, review POLLING PROCESSOR FAIL indication troubleshooting suggestions

- Turn the NC351(A) or NC351(A)/2 Central Equipment off and then back on and wait for the system to reboot.
- If the message returns, check 485A and 485B lines to the associated NC304 or NC304LCD Master Station. Refer to the **Voltage Readings** section.
- Also check the other connections from the central equipment to the master station.

SF337C or SF340B Bath Stations not placing calls

- Swap test the device with another “known-good” device. If the device works correctly in another location, examine the interconnection wiring. If it does not work, the device is suspected bad and must be replaced or repaired.
- To verify the device, review these 3 connections: brown wire—LED drive from the patient station, red wire—signal line to the patient station’s Bath Input, and orange wire—+12 VDC in from the patient station. When the device is operated, the +12 VDC from the orange wire is connected to the red wire to trigger the Bath Input on the patient station. This in turn activates the LED output on the patient station, which applies ground to the LED circuit, causing it to light via the brown wire.
- If the bath station and wiring appear to be correct, then the patient station can also be swap tested with another “known-good” patient station.

SF341B Code Station is not placing calls

- See **Code Fault Indication** for troubleshooting advice.

SF381 Standalone Bath Station or SF382 Standalone Code Station is not placing calls

These devices look like peripheral devices, but they function electronically just like IR3xx-series Patient Stations. They interact directly with the central equipment, rather than through an IR3xx-series Patient Station. Therefore, refer to these troubleshooting sections:

- **Comm. Fault Indication (patient station fault)**
- **IR3xx-series Patient Station is not placing calls**
- **IR3xx-series Patient Station that has been installed is not recognized by the system**

Part 2 – System Installation, Maintenance and Troubleshooting

System Troubleshooting Guide

Symptoms and Suggestions

continued

SF350B Nurse/Aide Presence Station is not registering or is not working correctly

- If the device is operating, but the LEDs are not lighting, check to see if the green or yellow dome lamps are working. If both are out, swap test the patient station and examine the peripheral connector's continuity.
- If only the lights are not working and the dome outputs are working, verify that there is roughly +12 VDC across the orange and yellow wires at the SF350B device's location. Verify the continuity of the red and green wires back to the peripheral connector on the patient station.
- If the device is not operating, the inputs on the patient station can be manually triggered by the application of the +12 VDC line (refer to **Voltage Readings** in this section for more details). The device can be directly connected for testing, and may also be swap tested with another "known-good" device for verification.

SF250 Staff Presence Station is not registering or is not working correctly

- If the device is operating, but the LED is not lighting, check to see if the green dome lamp is working. If the LED and lamp are both out, swap test the patient station and examine the peripheral connector's continuity.
- Verify that there is roughly +12 VDC across the purple and gray wires. Verify the continuity of the three wires going to the SF250.
- If the device is not operating, the input on the patient station can be manually triggered by the application of the +12 VDC line (refer to **Voltage Readings** in this section for more details). The device can be directly connected for testing, and may also be swap tested with another "known-good" device for verification.

Part 2 – System Installation, Maintenance and Troubleshooting

Event Printing (Sample)

```

03021 TESTCALL16 CHARS ROUTINE CALL 01-31 09:12
..C.....

03022 ROUTINE CALL 01-31 09:13
..C.....

03021 TESTCALL16 CHARS ROUTINE RESET 01-31 09:13
..C.....

03022 ROUTINE RESET 01-31 09:13
..C.....

03011 BATH CALL 01-31 09:13
..C.....

03011 BATH RESET 01-31 09:14
..C.....

01111 STAFF CALL 01-31 09:14
A.....

01111 STAFF RESET 01-31 09:14
A.....

02111 STAFF CALL 01-31 09:14
.B.....

02111 STAFF RESET 01-31 09:14
.B.....

Master 5 NURSE FLLW ON 01-31 09:14
ABCDEFGHIJKLMNPO
Master 5 NURSE FLLW OFF 01-31 09:14
ABCDEFGHIJKLMNPO
    
```

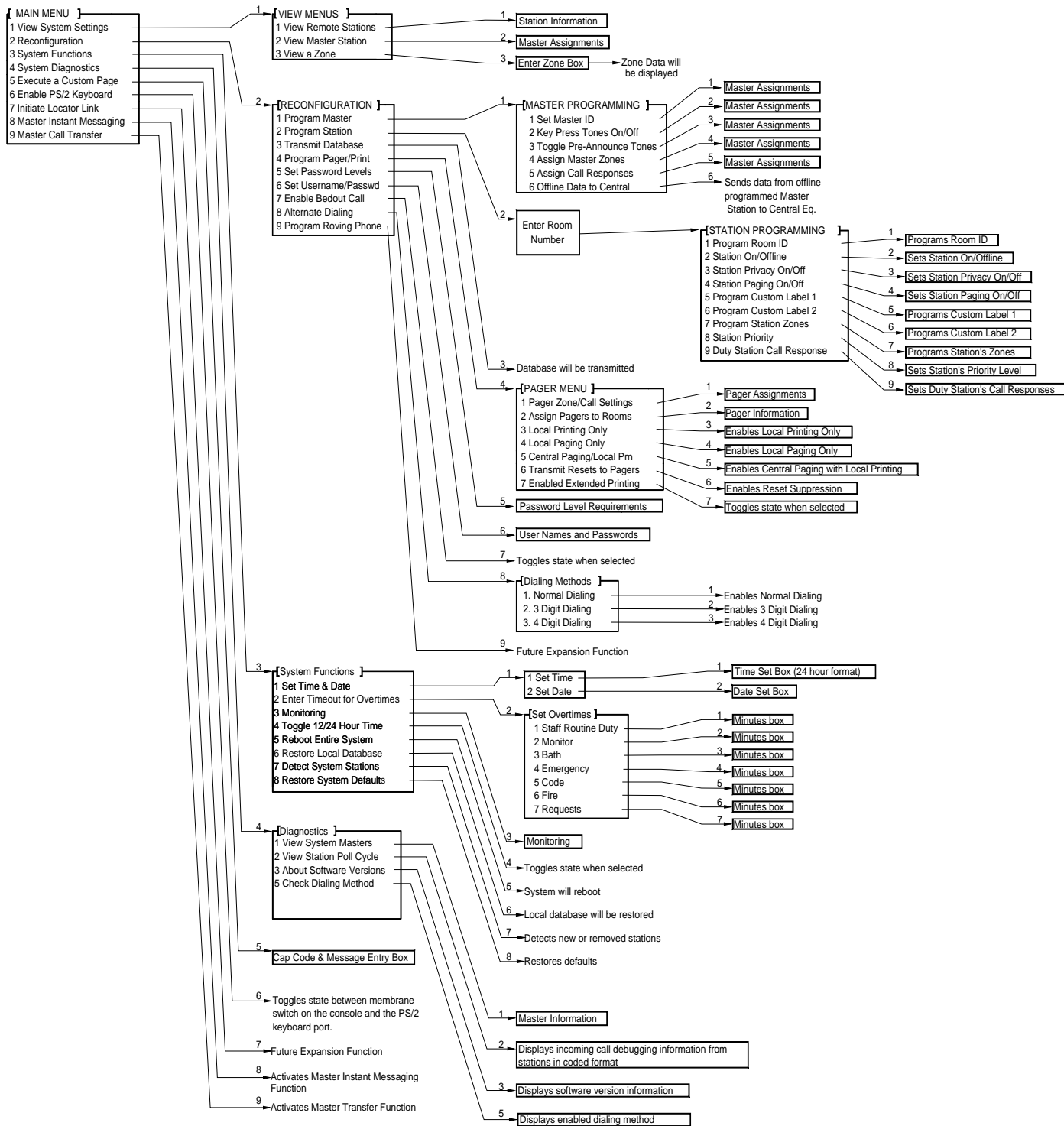

Figure 17 – Menu Map

Port + Address	Room Number	Bed No. 1 2		Online (Y/N)	Privacy (Y/N)	Paging (Y/N)	Label A (16 characters)	Label B (16 characters)	Zones (A-P, All)
8100									
8101									
8102									
8103									
8104									
8105									
8106									
8107									
8108									
8109									
8110									
8111									
8112									
8113									
8114									
8115									
8116									
8117									
8118									
8119									
8120									
8121									
8122									
8123									
8124									
8125									
8126									
8127									
8128									
8129									
8130									
8131									

Example of how information appears on "View Station" menu

8101	2501	1	2	Y	N	Y	MISS KAREN JONES	MRS JANICE SMITH	A C P
------	------	---	---	---	---	---	------------------	------------------	-------

Port + Address = Hardware Port, Unit Address
 (Ex: for 8120, 01 = Port 1;
 20 = Address value 20)

Room Number = Architectural room number

Bed No. = Bed Numbers

Online = Set station online or offline

Privacy = Set Privacy on or off

Paging = Set Paging on or off

Label = 16-character label—bed 1 & bed 2

Zones = Zone(s) station is programmed for system. Zone defaults to physical port the station is connected to.
 (Ex: 1=A, 2=B, etc.)

Port + Address	Room Number	Bed No.		Online (Y/N)	Privacy (Y/N)	Paging (Y/N)	Label A (16 characters)	Label B (16 characters)	Zones (A-P, All)
		1	2						
8132									
8133									
8134									
8135									
8136									
8137									
8138									
8139									
8140									
8141									
8142									
8143									
8144									
8145									
8146									
8147									
8148									
8149									
8150									
8151									
8152									
8153									
8154									
8155									
8156									
8157									
8158									
8159									
8160									
8161									
8162									
8163									

Example of how information appears on “View Station” menu

8101	2501	1	2	Y	N	Y	MISS KAREN JONES	MRS JANICE SMITH	A C P
------	------	---	---	---	---	---	------------------	------------------	-------

Port + Address = Hardware Port, Unit Address
 (Ex: for 8120, 01 = Port 1;
 20 = Address value 20)

Room Number = Architectural room number

Bed No. = Bed Numbers

Online = Set station online or offline

Privacy = Set Privacy on or off

Paging = Set Paging on or off

Label = 16-character label—bed 1 & bed 2

Zones = Zone(s) station is programmed for system. Zone defaults to physical port the station is connected to.
 (Ex: 1=A, 2=B, etc.)

Port + Address	Room Number	Bed No.		Online (Y/N)	Privacy (Y/N)	Paging (Y/N)	Label A (16 characters)	Label B (16 characters)	Zones (A-P, All)
		1	2						
8200									
8201									
8202									
8203									
8204									
8205									
8206									
8207									
8208									
8209									
8210									
8211									
8212									
8213									
8214									
8215									
8216									
8217									
8218									
8219									
8220									
8221									
8222									
8223									
8224									
8225									
8226									
8227									
8228									
8229									
8230									
8231									

Example of how information appears on "View Station" menu

8101	2501	1	2	Y	N	Y	MISS KAREN JONES	MRS JANICE SMITH	A C P
------	------	---	---	---	---	---	------------------	------------------	-------

Port + Address = Hardware Port, Unit Address
 (Ex: for 8120, 01 = Port 1;
 20 = Address value 20)

Room Number = Architectural room number

Bed No. = Bed Numbers

Online = Set station online or offline

Privacy = Set Privacy on or off

Paging = Set Paging on or off

Label = 16-character label—bed 1 & bed 2

Zones = Zone(s) station is programmed for system. Zone defaults to physical port the station is connected to.
 (Ex: 1=A, 2=B, etc.)

Port + Address	Room Number	Bed No.		Online (Y/N)	Privacy (Y/N)	Paging (Y/N)	Label A (16 characters)	Label B (16 characters)	Zones (A-P, All)
		1	2						
8232									
8233									
8234									
8235									
8236									
8237									
8238									
8239									
8240									
8241									
8242									
8243									
8244									
8245									
8246									
8247									
8248									
8249									
8250									
8251									
8252									
8253									
8254									
8255									
8256									
8257									
8258									
8259									
8260									
8261									
8262									
8263									

Example of how information appears on "View Station" menu

8101	2501	1	2	Y	N	Y	MISS KAREN JONES	MRS JANICE SMITH	A C P
------	------	---	---	---	---	---	------------------	------------------	-------

Port + Address = Hardware Port, Unit Address
 (Ex: for 8120, 01 = Port 1;
 20 = Address value 20)

Room Number = Architectural room number

Bed No. = Bed Numbers

Online = Set station online or offline

Privacy = Set Privacy on or off

Paging = Set Paging on or off

Label = 16-character label—bed 1 & bed 2

Zones = Zone(s) station is programmed for system. Zone defaults to physical port the station is connected to.
 (Ex: 1=A, 2=B, etc.)

Port + Address	Room Number	Bed No.		Online (Y/N)	Privacy (Y/N)	Paging (Y/N)	Label A (16 characters)	Label B (16 characters)	Zones (A-P, All)
		1	2						
8300									
8301									
8302									
8303									
8304									
8305									
8306									
8307									
8308									
8309									
8310									
8311									
8312									
8313									
8314									
8315									
8316									
8317									
8318									
8319									
8320									
8321									
8322									
8323									
8324									
8325									
8326									
8327									
8328									
8329									
8330									
8331									

Example of how information appears on "View Station" menu

8101	2501	1	2	Y	N	Y	MISS KAREN JONES	MRS JANICE SMITH	A C P
------	------	---	---	---	---	---	------------------	------------------	-------

Port + Address = Hardware Port, Unit Address
 (Ex: for 8120, 01 = Port 1;
 20 = Address value 20)

Room Number = Architectural room number

Bed No. = Bed Numbers

Online = Set station online or offline

Privacy = Set Privacy on or off

Paging = Set Paging on or off

Label = 16-character label—bed 1 & bed 2

Zones = Zone(s) station is programmed for system. Zone defaults to physical port the station is connected to.
 (Ex: 1=A, 2=B, etc.)

Port + Address	Room Number	Bed No. 1 2	Online (Y/N)	Privacy (Y/N)	Paging (Y/N)	Label A (16 characters)	Label B (16 characters)	Zones (A-P, All)
8332								
8333								
8334								
8335								
8336								
8337								
8338								
8339								
8340								
8341								
8342								
8343								
8344								
8345								
8346								
8347								
8348								
8349								
8350								
8351								
8352								
8353								
8354								
8355								
8356								
8357								
8358								
8359								
8360								
8361								
8362								
8363								

Example of how information appears on "View Station" menu

8101	2501	1	2	Y	N	Y	MISS KAREN JONES	MRS JANICE SMITH	A C P
------	------	---	---	---	---	---	------------------	------------------	-------

Port + Address = Hardware Port, Unit Address
 (Ex: for 8120, 01 = Port 1;
 20 = Address value 20)

Room Number = Architectural room number

Bed No. = Bed Numbers

Online = Set station online or offline

Privacy = Set Privacy on or off

Paging = Set Paging on or off

Label = 16-character label—bed 1 & bed 2

Zones = Zone(s) station is programmed for system. Zone defaults to physical port the station is connected to.
 (Ex: 1=A, 2=B, etc.)

Port + Address	Room Number	Bed No.		Online (Y/N)	Privacy (Y/N)	Paging (Y/N)	Label A (16 characters)	Label B (16 characters)	Zones (A-P, All)
		1	2						
8400									
8401									
8402									
8403									
8404									
8405									
8406									
8407									
8408									
8409									
8410									
8411									
8412									
8413									
8414									
8415									
8416									
8417									
8418									
8419									
8420									
8421									
8422									
8423									
8424									
8425									
8426									
8427									
8428									
8429									
8430									
8431									

Example of how information appears on "View Station" menu

8101	2501	1	2	Y	N	Y	MISS KAREN JONES	MRS JANICE SMITH	A C P
------	------	---	---	---	---	---	------------------	------------------	-------

Port + Address = Hardware Port, Unit Address
 (Ex: for 8120, 01 = Port 1;
 20 = Address value 20)

Room Number = Architectural room number

Bed No. = Bed Numbers

Online = Set station online or offline

Privacy = Set Privacy on or off

Paging = Set Paging on or off

Label = 16-character label—bed 1 & bed 2

Zones = Zone(s) station is programmed for system. Zone defaults to physical port the station is connected to.
 (Ex: 1=A, 2=B, etc.)

Port + Address	Room Number	Bed No. 1 2	Online (Y/N)	Privacy (Y/N)	Paging (Y/N)	Label A (16 characters)	Label B (16 characters)	Zones (A-P, All)
8432								
8433								
8434								
8435								
8436								
8437								
8438								
8439								
8440								
8441								
8442								
8443								
8444								
8445								
8446								
8447								
8448								
8449								
8450								
8451								
8452								
8453								
8454								
8455								
8456								
8457								
8458								
8459								
8460								
8461								
8462								
8463								

Example of how information appears on “View Station” menu

8101	2501	1	2	Y	N	Y	MISS KAREN JONES	MRS JANICE SMITH	A C P
------	------	---	---	---	---	---	------------------	------------------	-------

Port + Address = Hardware Port, Unit Address
 (Ex: for 8120, 01 = Port 1;
 20 = Address value 20)

Room Number = Architectural room number

Bed No. = Bed Numbers

Online = Set station online or offline

Privacy = Set Privacy on or off

Paging = Set Paging on or off

Label = 16-character label—bed 1 & bed 2

Zones = Zone(s) station is programmed for system. Zone defaults to physical port the station is connected to.
 (Ex: 1=A, 2=B, etc.)

Port + Address	Room Number	Bed No.		Online (Y/N)	Privacy (Y/N)	Paging (Y/N)	Label A (16 characters)	Label B (16 characters)	Zones (A-P, All)
		1	2						
8500									
8501									
8502									
8503									
8504									
8505									
8506									
8507									
8508									
8509									
8510									
8511									
8512									
8513									
8514									
8515									
8516									
8517									
8518									
8519									
8520									
8521									
8522									
8523									
8524									
8525									
8526									
8527									
8528									
8529									
8530									
8531									

Example of how information appears on "View Station" menu

8101	2501	1	2	Y	N	Y	MISS KAREN JONES	MRS JANICE SMITH	A C P
------	------	---	---	---	---	---	------------------	------------------	-------

Port + Address = Hardware Port, Unit Address
 (Ex: for 8120, 01 = Port 1;
 20 = Address value 20)

Room Number = Architectural room number

Bed No. = Bed Numbers

Online = Set station online or offline

Privacy = Set Privacy on or off

Paging = Set Paging on or off

Label = 16-character label—bed 1 & bed 2

Zones = Zone(s) station is programmed for system. Zone defaults to physical port the station is connected to.
 (Ex: 1=A, 2=B, etc.)

Port + Address	Room Number	Bed No. 1 2	Online (Y/N)	Privacy (Y/N)	Paging (Y/N)	Label A (16 characters)	Label B (16 characters)	Zones (A-P, All)
8532								
8533								
8534								
8535								
8536								
8537								
8538								
8539								
8540								
8541								
8542								
8543								
8544								
8545								
8546								
8547								
8548								
8549								
8550								
8551								
8552								
8553								
8554								
8555								
8556								
8557								
8558								
8559								
8560								
8561								
8562								
8563								

Example of how information appears on “View Station” menu

8101	2501	1	2	Y	N	Y	MISS KAREN JONES	MRS JANICE SMITH	A C P
------	------	---	---	---	---	---	------------------	------------------	-------

Port + Address = Hardware Port, Unit Address
 (Ex: for 8120, 01 = Port 1;
 20 = Address value 20)

Room Number = Architectural room number

Bed No. = Bed Numbers

Online = Set station online or offline

Privacy = Set Privacy on or off

Paging = Set Paging on or off

Label = 16-character label—bed 1 & bed 2

Zones = Zone(s) station is programmed for system. Zone defaults to physical port the station is connected to.
 (Ex: 1=A, 2=B, etc.)

Port + Address	Room Number	Bed No.		Online (Y/N)	Privacy (Y/N)	Paging (Y/N)	Label A (16 characters)	Label B (16 characters)	Zones (A-P, All)
		1	2						
8600									
8601									
8602									
8603									
8604									
8605									
8606									
8607									
8608									
8609									
8610									
8611									
8612									
8613									
8614									
8615									
8616									
8617									
8618									
8619									
8620									
8621									
8622									
8623									
8624									
8625									
8626									
8627									
8628									
8629									
8630									
8631									

Example of how information appears on "View Station" menu

8101	2501	1	2	Y	N	Y	MISS KAREN JONES	MRS JANICE SMITH	A C P
------	------	---	---	---	---	---	------------------	------------------	-------

- Port + Address = Hardware Port, Unit Address
(Ex: for 8120, 01 = Port 1;
20 = Address value 20)
- Room Number = Architectural room number
- Bed No. = Bed Numbers
- Online = Set station online or offline
- Privacy = Set Privacy on or off

- Paging = Set Paging on or off
- Label = 16-character label—bed 1 & bed 2
- Zones = Zone(s) station is programmed for system. Zone defaults to physical port the station is connected to.
(Ex: 1=A, 2=B, etc.)

Port + Address	Room Number	Bed No. 1 2	Online (Y/N)	Privacy (Y/N)	Paging (Y/N)	Label A (16 characters)	Label B (16 characters)	Zones (A-P, All)
8632								
8633								
8634								
8635								
8636								
8637								
8638								
8639								
8640								
8641								
8642								
8643								
8644								
8645								
8646								
8647								
8648								
8649								
8650								
8651								
8652								
8653								
8654								
8655								
8656								
8657								
8658								
8659								
8660								
8661								
8662								
8663								

Example of how information appears on “View Station” menu

8101	2501	1	2	Y	N	Y	MISS KAREN JONES	MRS JANICE SMITH	A C P
------	------	---	---	---	---	---	------------------	------------------	-------

Port + Address = Hardware Port, Unit Address
 (Ex: for 8120, 01 = Port 1;
 20 = Address value 20)

Room Number = Architectural room number

Bed No. = Bed Numbers

Online = Set station online or offline

Privacy = Set Privacy on or off

Paging = Set Paging on or off

Label = 16-character label—bed 1 & bed 2

Zones = Zone(s) station is programmed for system. Zone defaults to physical port the station is connected to.
 (Ex: 1=A, 2=B, etc.)

Port + Address	Room Number	Bed No. 1 2	Online (Y/N)	Privacy (Y/N)	Paging (Y/N)	Label A (16 characters)	Label B (16 characters)	Zones (A-P, All)
8700								
8701								
8702								
8703								
8704								
8705								
8706								
8707								
8708								
8709								
8710								
8711								
8712								
8713								
8714								
8715								
8716								
8717								
8718								
8719								
8720								
8721								
8722								
8723								
8724								
8725								
8726								
8727								
8728								
8729								
8730								
8731								

Example of how information appears on "View Station" menu

8101	2501	1	2	Y	N	Y	MISS KAREN JONES	MRS JANICE SMITH	A C P
------	------	---	---	---	---	---	------------------	------------------	-------

Port + Address = Hardware Port, Unit Address
 (Ex: for 8120, 01 = Port 1;
 20 = Address value 20)

Room Number = Architectural room number

Bed No. = Bed Numbers

Online = Set station online or offline

Privacy = Set Privacy on or off

Paging = Set Paging on or off

Label = 16-character label—bed 1 & bed 2

Zones = Zone(s) station is programmed for system. Zone defaults to physical port the station is connected to.
 (Ex: 1=A, 2=B, etc.)

Port + Address	Room Number	Bed No. 1 2	Online (Y/N)	Privacy (Y/N)	Paging (Y/N)	Label A (16 characters)	Label B (16 characters)	Zones (A-P, All)
8732								
8733								
8734								
8735								
8736								
8737								
8738								
8739								
8740								
8741								
8742								
8743								
8744								
8745								
8746								
8747								
8748								
8749								
8750								
8751								
8752								
8753								
8754								
8755								
8756								
8757								
8758								
8759								
8760								
8761								
8762								
8763								

Example of how information appears on “View Station” menu

8101	2501	1	2	Y	N	Y	MISS KAREN JONES	MRS JANICE SMITH	A C P
------	------	---	---	---	---	---	------------------	------------------	-------

Port + Address = Hardware Port, Unit Address
 (Ex: for 8120, 01 = Port 1;
 20 = Address value 20)

Room Number = Architectural room number

Bed No. = Bed Numbers

Online = Set station online or offline

Privacy = Set Privacy on or off

Paging = Set Paging on or off

Label = 16-character label—bed 1 & bed 2

Zones = Zone(s) station is programmed for system. Zone defaults to physical port the station is connected to.
 (Ex: 1=A, 2=B, etc.)

Port + Address	Room Number	Bed No.		Online (Y/N)	Privacy (Y/N)	Paging (Y/N)	Label A (16 characters)	Label B (16 characters)	Zones (A-P, All)
		1	2						
8800									
8801									
8802									
8803									
8804									
8805									
8806									
8807									
8808									
8809									
8810									
8811									
8812									
8813									
8814									
8815									
8816									
8817									
8818									
8819									
8820									
8821									
8822									
8823									
8824									
8825									
8826									
8827									
8828									
8829									
8830									
8831									

Example of how information appears on "View Station" menu

8101	2501	1	2	Y	N	Y	MISS KAREN JONES	MRS JANICE SMITH	A C P
------	------	---	---	---	---	---	------------------	------------------	-------

Port + Address = Hardware Port, Unit Address
 (Ex: for 8120, 01 = Port 1;
 20 = Address value 20)

Room Number = Architectural room number

Bed No. = Bed Numbers

Online = Set station online or offline

Privacy = Set Privacy on or off

Paging = Set Paging on or off

Label = 16-character label—bed 1 & bed 2

Zones = Zone(s) station is programmed for system. Zone defaults to physical port the station is connected to.
 (Ex: 1=A, 2=B, etc.)

Port + Address	Room Number	Bed No.		Online (Y/N)	Privacy (Y/N)	Paging (Y/N)	Label A (16 characters)	Label B (16 characters)	Zones (A-P, All)
		1	2						
8832									
8833									
8834									
8835									
8836									
8837									
8838									
8839									
8840									
8841									
8842									
8843									
8844									
8845									
8846									
8847									
8848									
8849									
8850									
8851									
8852									
8853									
8854									
8855									
8856									
8857									
8858									
8859									
8860									
8861									
8862									
8863									

Example of how information appears on "View Station" menu

8101	2501	1	2	Y	N	Y	MISS KAREN JONES	MRS JANICE SMITH	A C P
------	------	---	---	---	---	---	------------------	------------------	-------

Port + Address = Hardware Port, Unit Address
 (Ex: for 8120, 01 = Port 1;
 20 = Address value 20)

Room Number = Architectural room number

Bed No. = Bed Numbers

Online = Set station online or offline

Privacy = Set Privacy on or off

Paging = Set Paging on or off

Label = 16-character label—bed 1 & bed 2

Zones = Zone(s) station is programmed for system. Zone defaults to physical port the station is connected to.
 (Ex: 1=A, 2=B, etc.)

Figure 26—Tek-CARE® NC300™ II System Connection Diagram

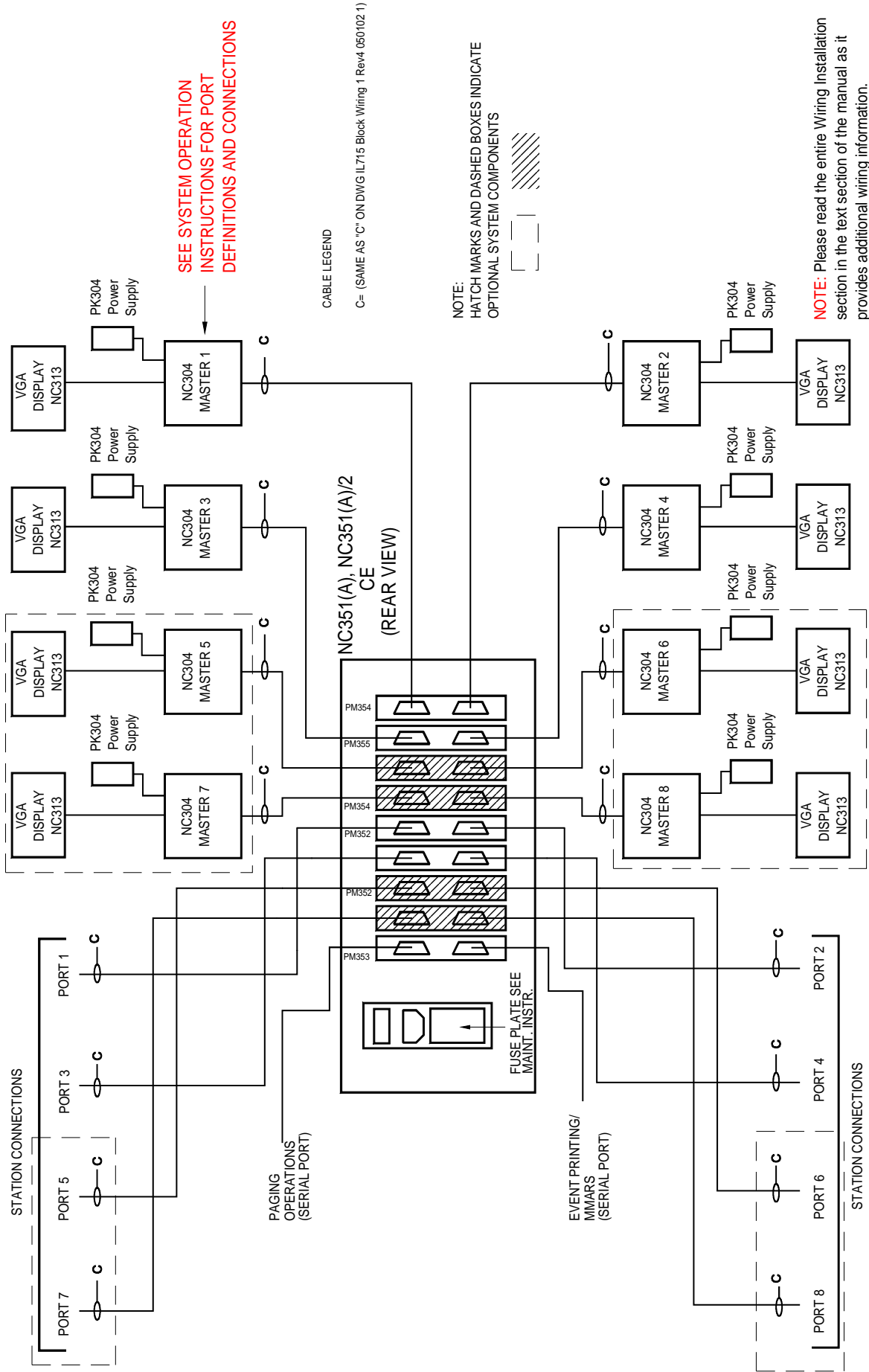

Drawing Name & Number: IL715 Block Wiring 2 Rev4 042004 1

Figure 27—NC304/NC306 Block Wiring Diagram

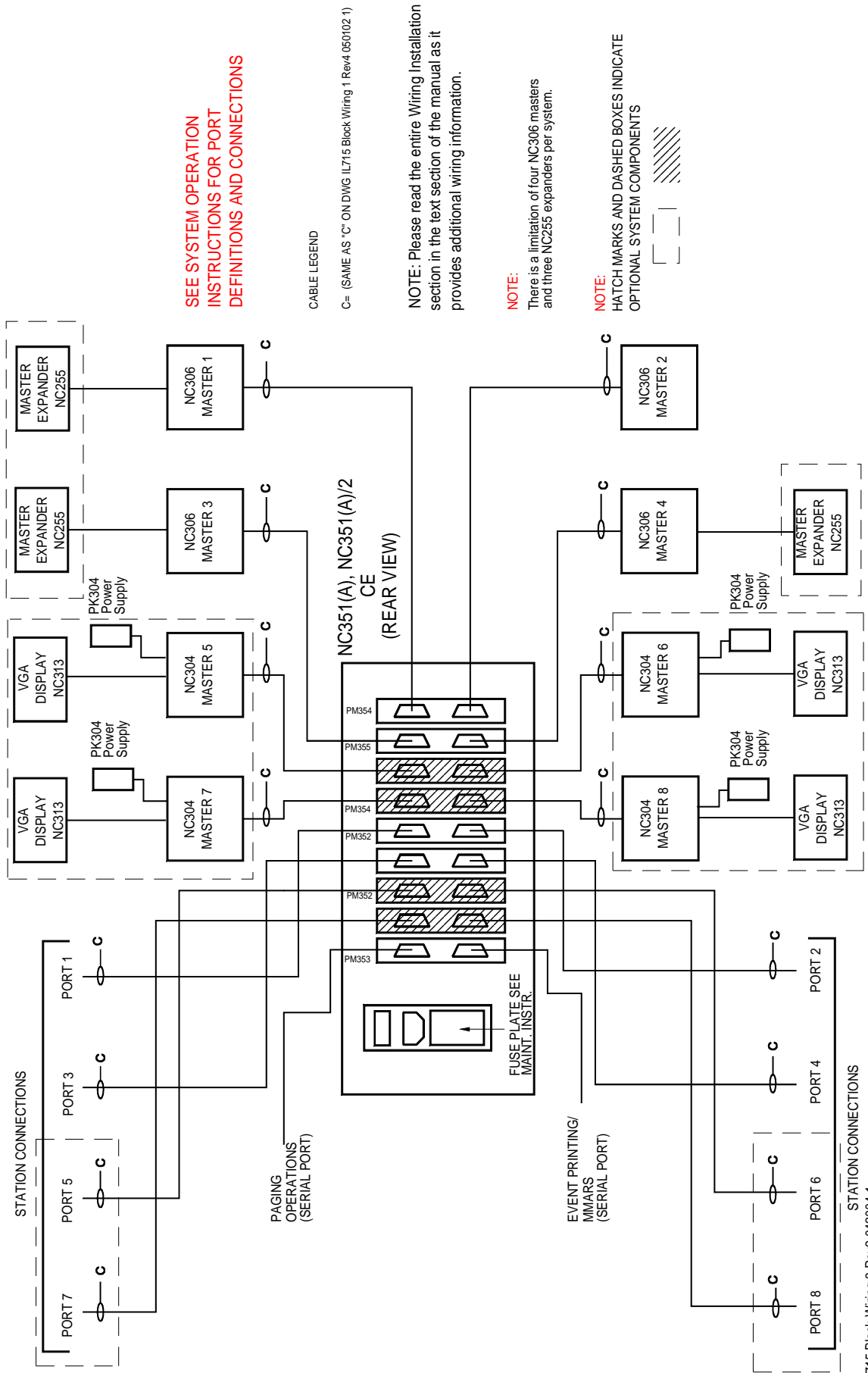

SEE SYSTEM OPERATION INSTRUCTIONS FOR PORT DEFINITIONS AND CONNECTIONS

CABLE LEGEND

C= (SAME AS "C" ON DWG IL715 Block Wiring 1 Rev4 050102.1)

NOTE: Please read the entire Wiring Installation section in the text section of the manual as it provides additional wiring information.

NOTE:

There is a limitation of four NC306 masters and three NC255 expanders per system.

NOTE: HATCH MARKS AND DASHED BOXES INDICATE OPTIONAL SYSTEM COMPONENTS

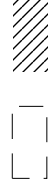

Figure 28—NC351(A) Wiring Diagram Using Individual Cables

NC351(A) Cable Requirements Using Individual Cables

Maximum number of stations on any one cable run: 32 without DOME LAMPS
16 with DOME LAMPS

Maximum number of stations on a port: 64

Note: Total combined cable lengths using #18 wire cannot exceed 1000 ft.

NOTE: Please read the entire Wiring Installation section in the text section of the manual as it provides additional wiring information.

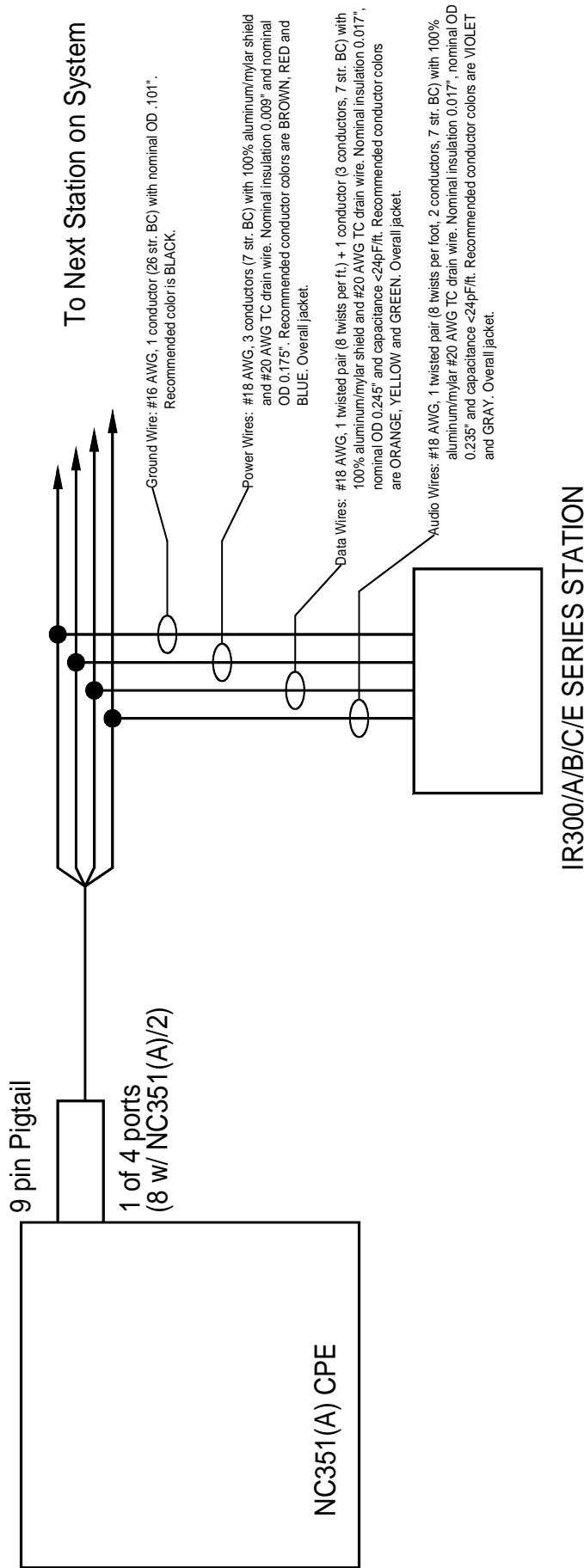

Drawing Name & Number: IL715 Port Wiring 1 Rev7 101706 1

Figure 29—NC304, NC304LCD, NC306 Wiring to Central Equipment

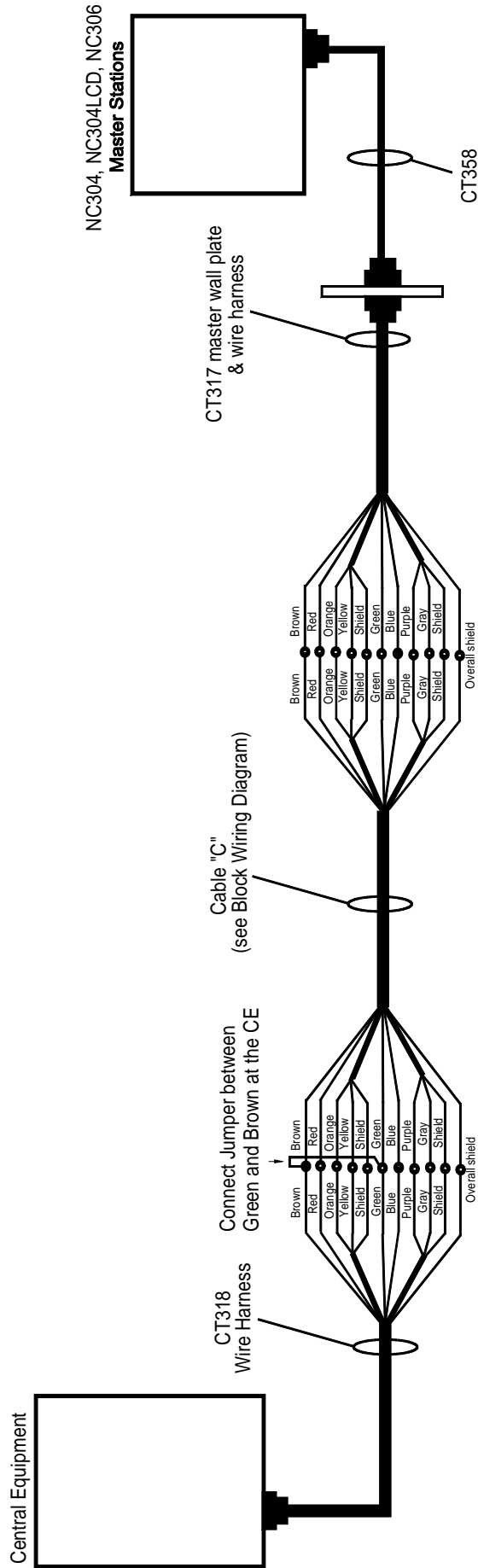

Drawing Name & Number: IL715 NC304ser NC306 Wiring Drawing Rev0 021202 1

Figure 30—Connector Interconnections for Addressable Stations

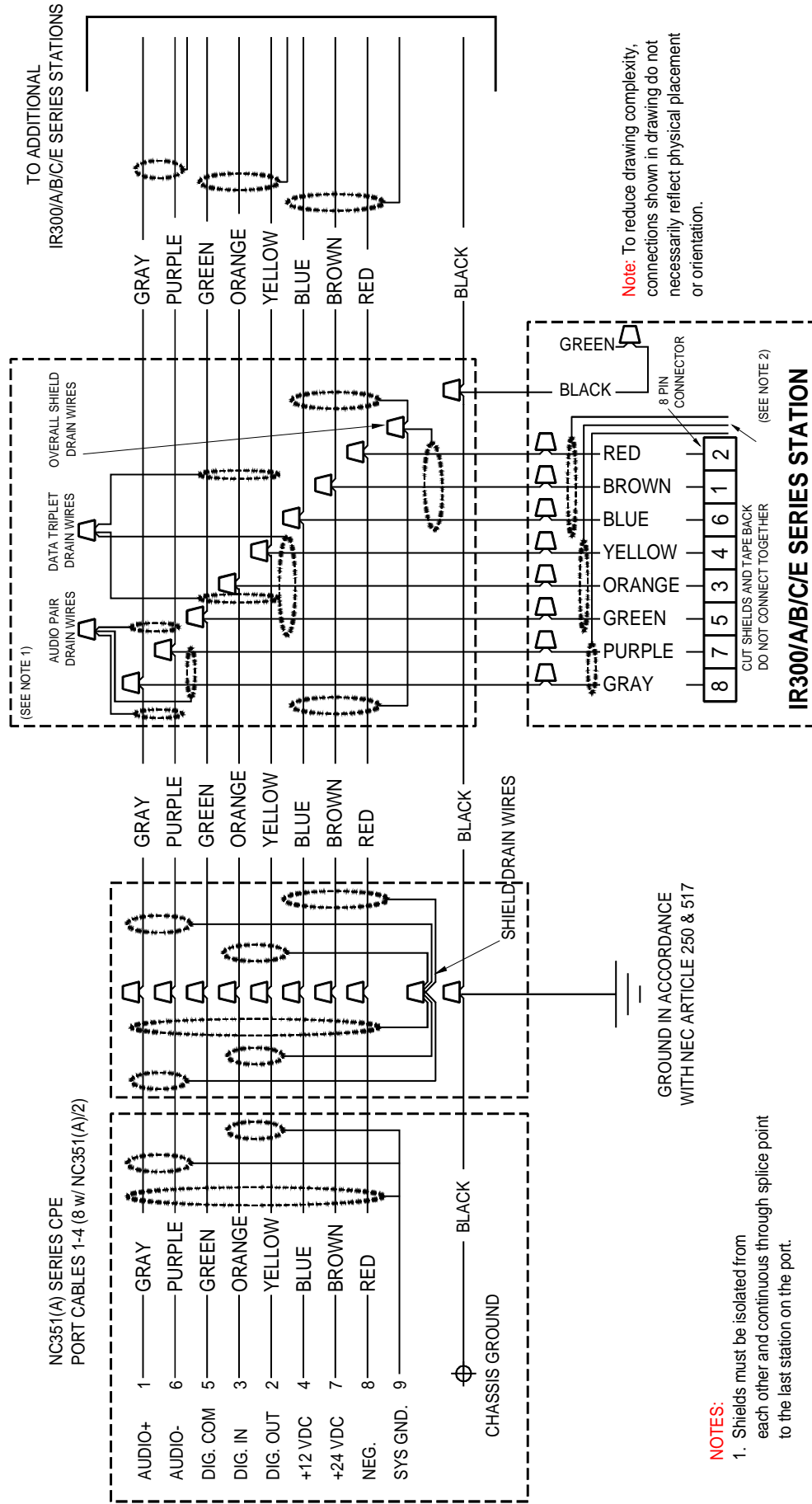
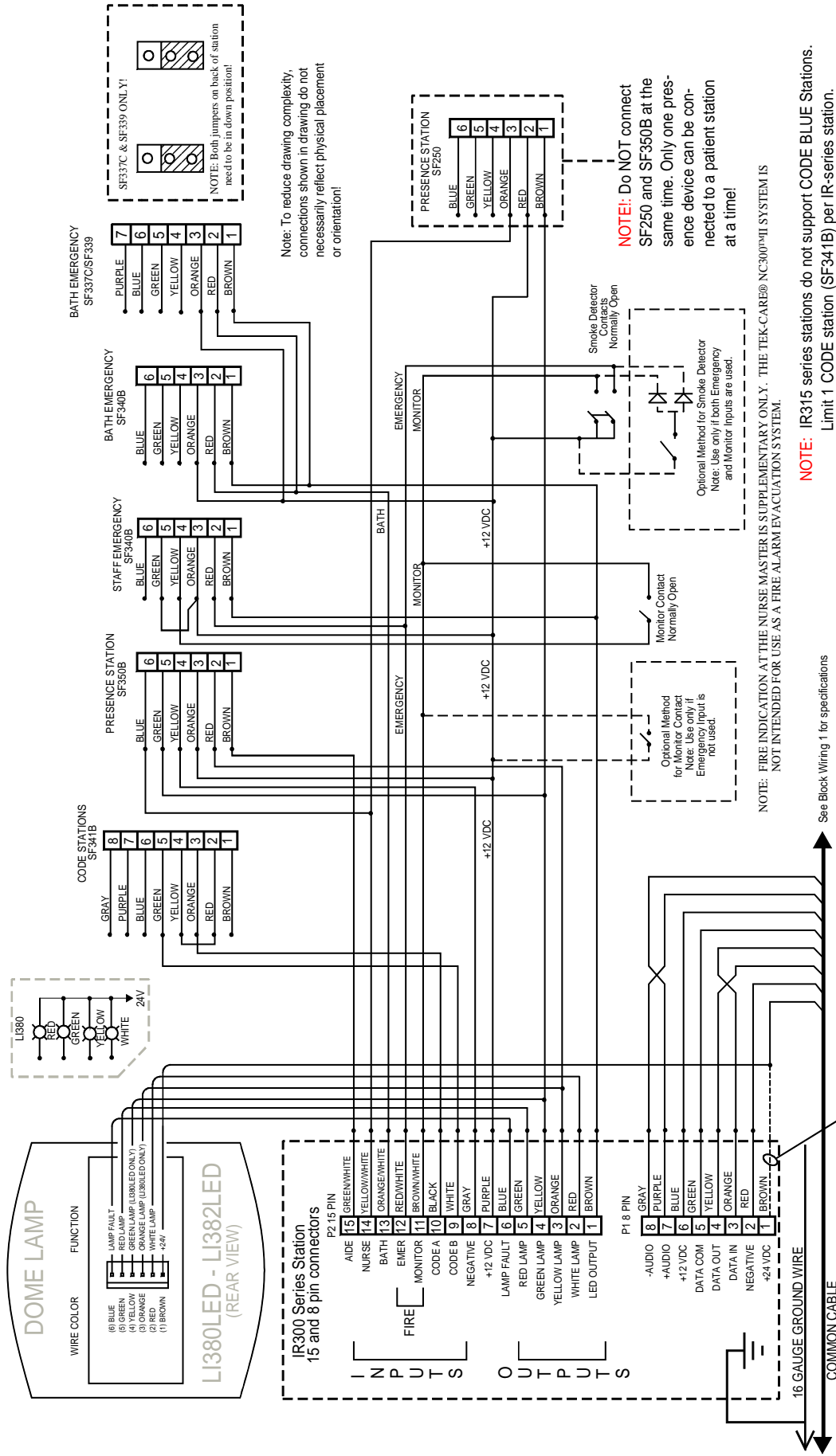

Figure 31—IR3xx-series Connections to Peripheral Devices



Drawing Name & Number: IL715 IR300 Series Wiring 1 Rev10 092710 1

See Block Wiring 1 for specifications
 DO NOT CONNECT IF USING RY351B
 To NC351(A) CE

Figure 32—IR3xx-series Connections with Supervised Dome Light

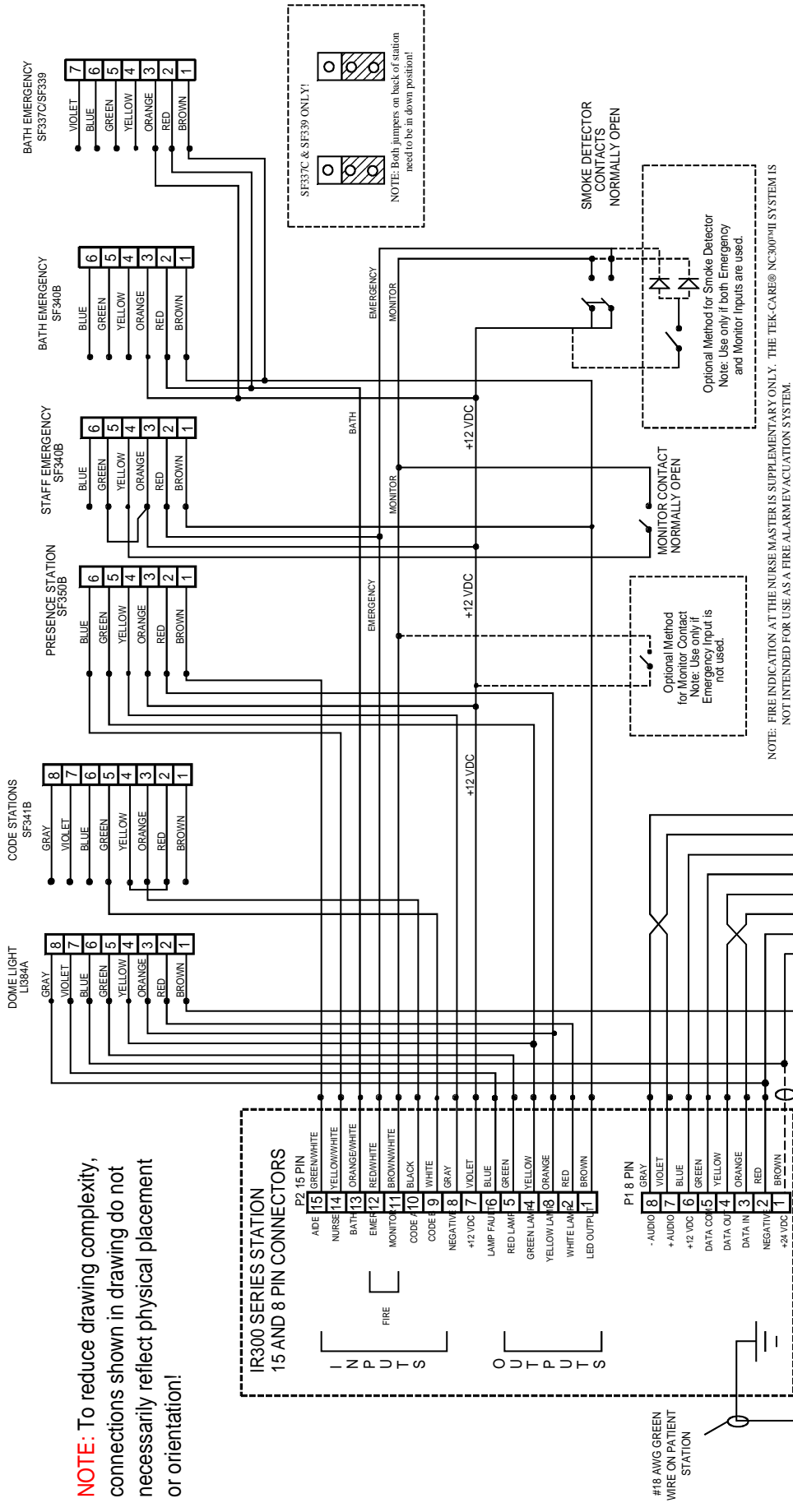

NOTE: To reduce drawing complexity, connections shown in drawing do not necessarily reflect physical placement or orientation!

NOTE: IR315 SERIES DOES NOT SUPPORT CODE BLUE STATIONS.
Limit 1 CODE station (SF341B) per IR-series station.

DO NOT CONNECT IF USING RY351B 16 GAUGE GROUND WIRE (CONNECT TO BURNISHED SCREW POINT ON CENTRAL EQUIPMENT CHASSIS)

Drawing Name & Number: IL715 IR300 Series Wiring 2 Rev9 031010 1

Figure 33—LI386-series Dome/Zone Light Wiring Diagram

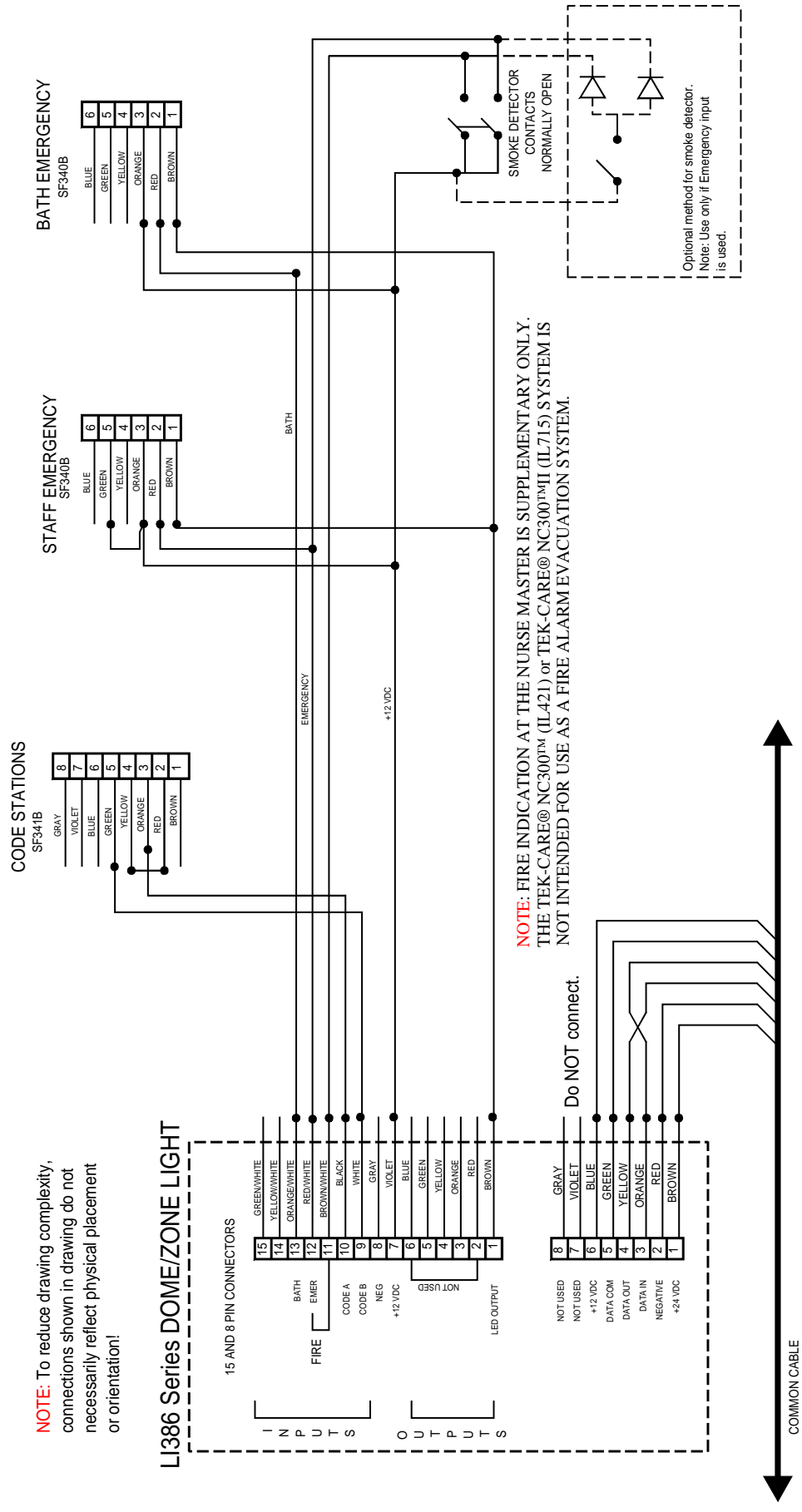

To NC351(A) (IL715) or NC350C (IL421) Series CE

Drawing Name & Number: IL715 IL421 LI386 Series Wiring Rev6 041105

Figure 34—RY351B Wiring Diagram

NOTE: To reduce drawing complexity, connections shown in drawing do not necessarily reflect physical placement or orientation!

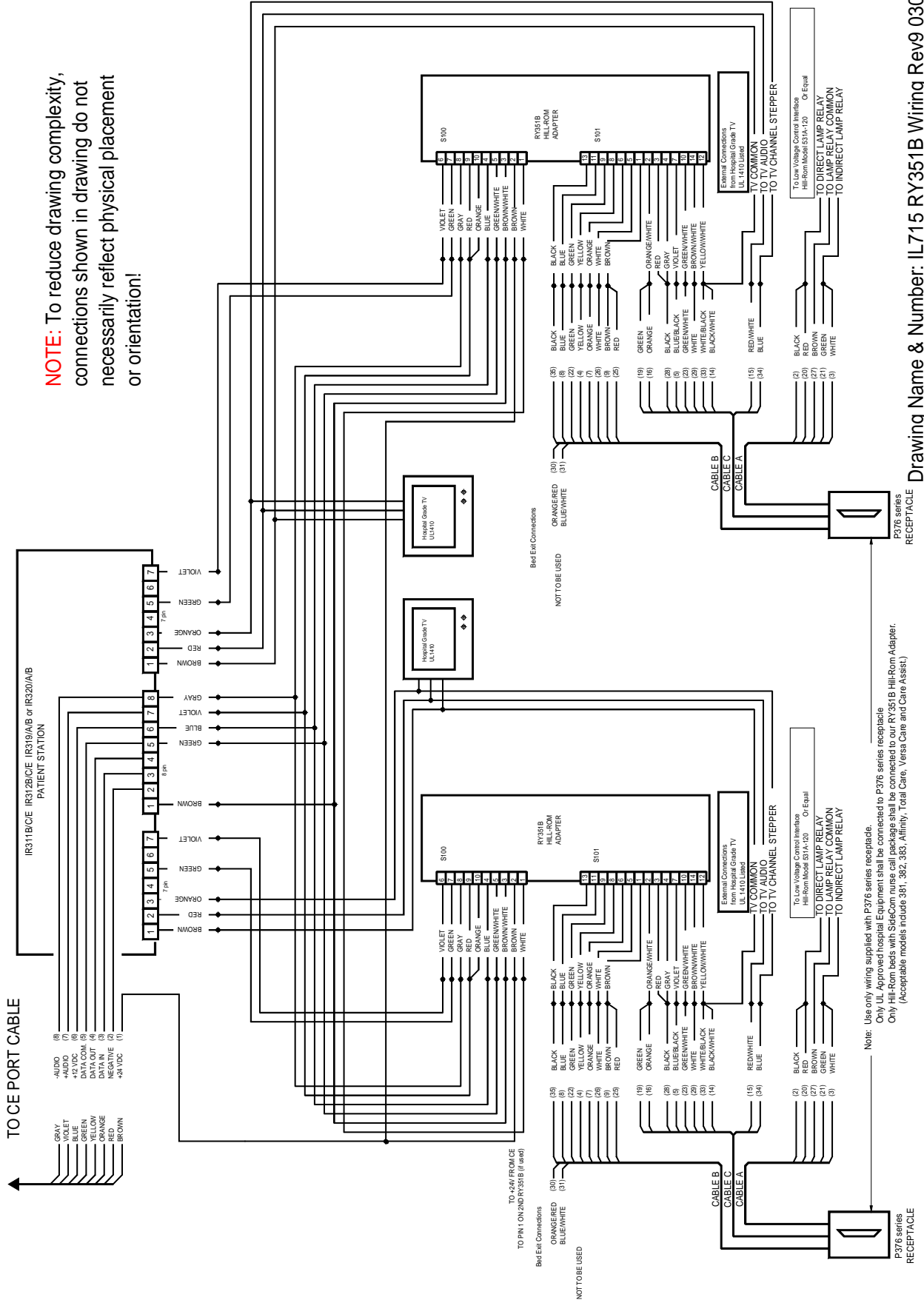

Drawing Name & Number: IL715 RY351B Wiring Rev9 030608 1

Figure 35—RY350B Wiring Diagram

NOTE: To reduce drawing complexity, connections shown in drawing do not necessarily reflect physical placement or orientation!

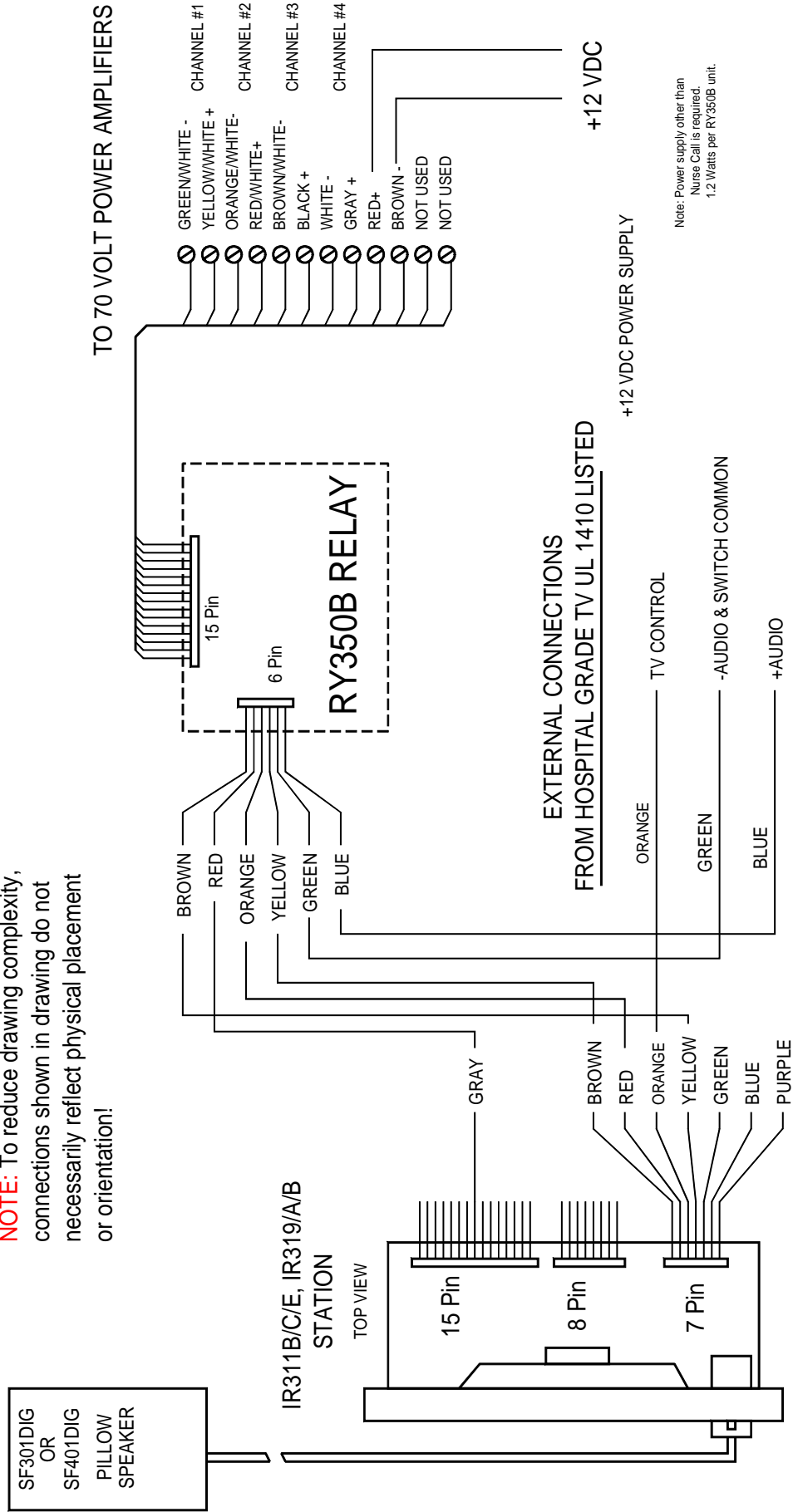

Note: For remaining connections see diagrams:
 IL715 IR300B-C Ser Wiring 1 Rev5 033103 1
 IL715 IR300B-C Ser Wiring 2 Rev4 033103 1

Note: This should be duplicated for IR312B/C/E or IR320/A/B Dual Patient Stations

Drawing Name & Number: IL715 RY350B Wiring Rev6 101806 1

Figure 36—PM321B/PM322B Lamp Module Wiring Diagram

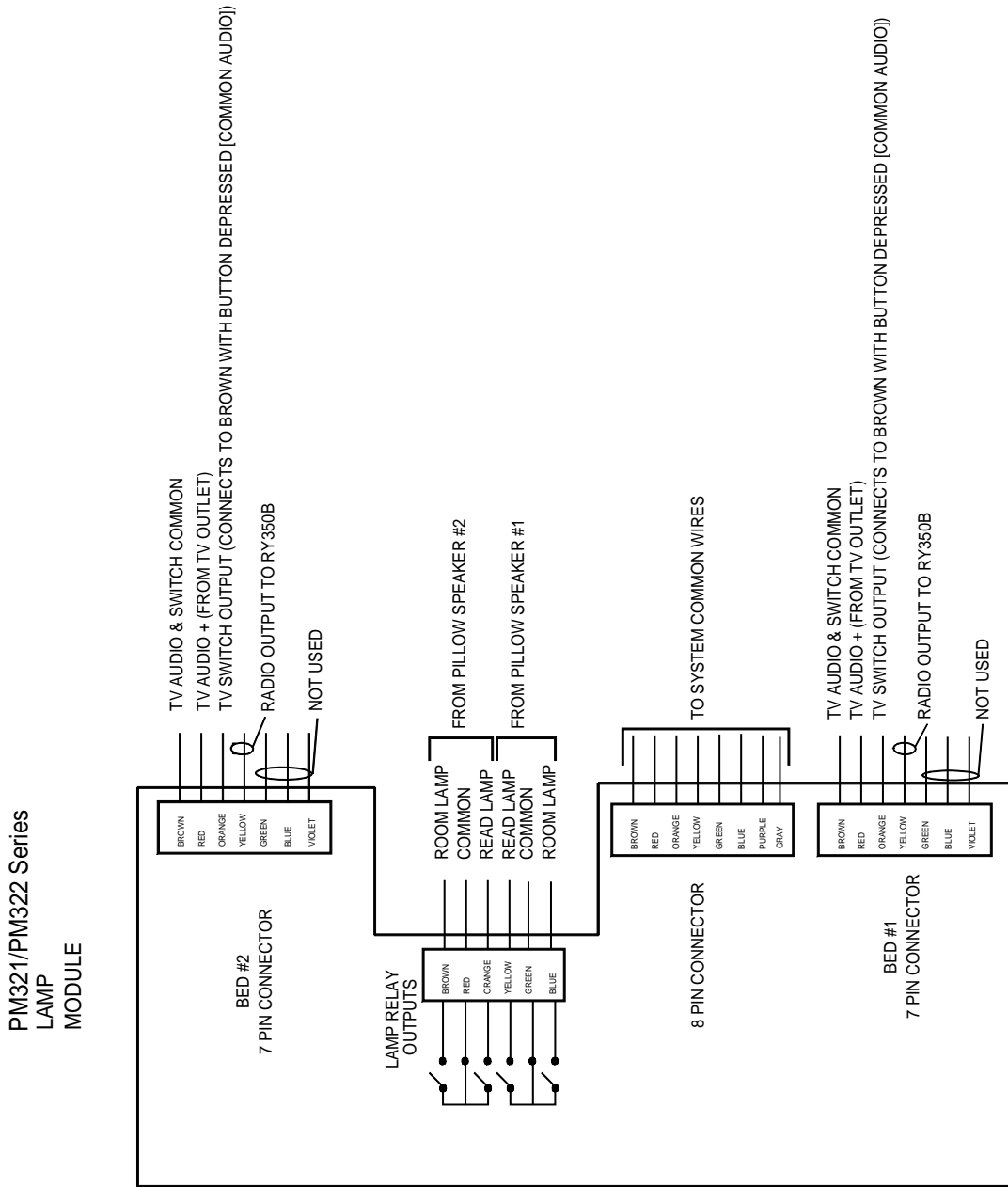

Drawing Name & Number: IL715 PM321 PM322 Series Connections Rev2 041

Figure 37—LI384A Multiple Stations

NOTE: To reduce drawing complexity, connections shown in drawing do not necessarily reflect physical placement or orientation!

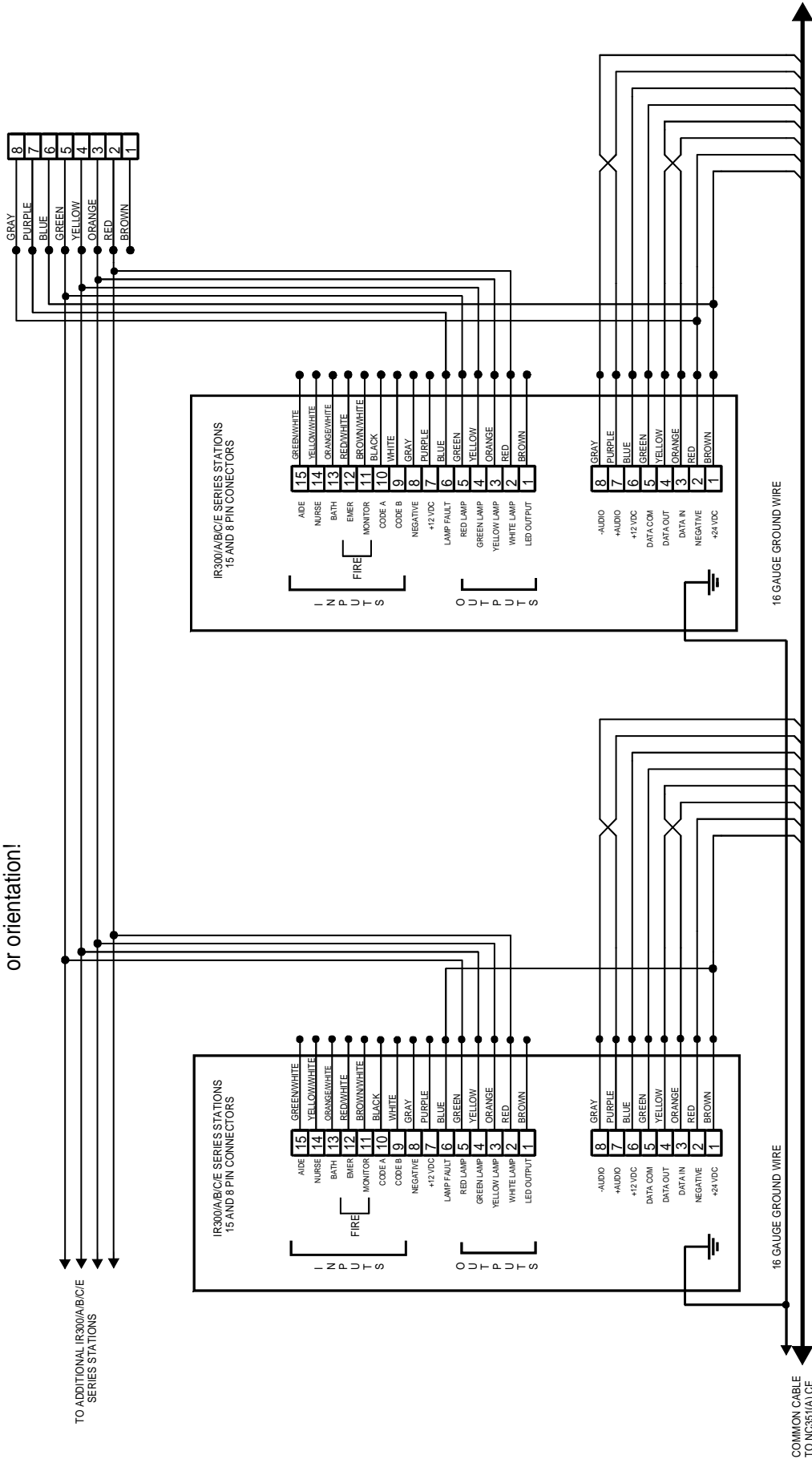

Drawing Name & Number: IL715 LI384A Multi-Wiring Rev6 101806 1

Figure 38—6 & 7-PIN Connector Outputs for IR3xx-series Stations

**7 PIN CONNECTOR
IR300B/C/E STATION**

PURPLE	7	V-out
BLUE	6	CORD OUT INPUT (Use w/ V-out)
GREEN	5	NOT USED
YELLOW	4	CALL INPUT (Use w/ V-out)
ORANGE	3	CANCEL INPUT (Use w/ V-out)
RED	2	+ AUDIO OUT
BROWN	1	- AUDIO OUT

**7 PIN CONNECTOR
IR311B/C/E, IR312B/C/E, IR319/A/B, IR320/A/B STATION**

PURPLE	7	CALL LED OUTPUT
BLUE	6	CONTROL (PM311C/PM312C ONLY)
GREEN	5	CALL INPUT +12 VDC
YELLOW	4	RADIO OUT +12 VDC
ORANGE	3	TV ON/OFF SWITCH
RED	2	TV + AUDIO
BROWN	1	TV - COMMON

**6 PIN CONNECTOR
IR300A STATION**

BLUE	6	+12 VDC
GREEN	5	CALL LED INPUT
YELLOW	4	CALL INPUT +12 VDC
ORANGE	3	CANCEL INPUT +12 VDC
RED	2	+ AUDIO OUT
BROWN	1	- AUDIO OUT

**6 PIN CONNECTOR
IR311A, IR312A STATION**

BLUE	6	CALL LED INPUT
GREEN	5	CONTROL (PM311C/PM312C ONLY)
YELLOW	4	RADIO OUTPUT +12 VDC
ORANGE	3	TV ON/OFF SWITCH
RED	2	TV + AUDIO
BROWN	1	TV COMMON

Figure 39—NC351(A) Serial Connection Diagram

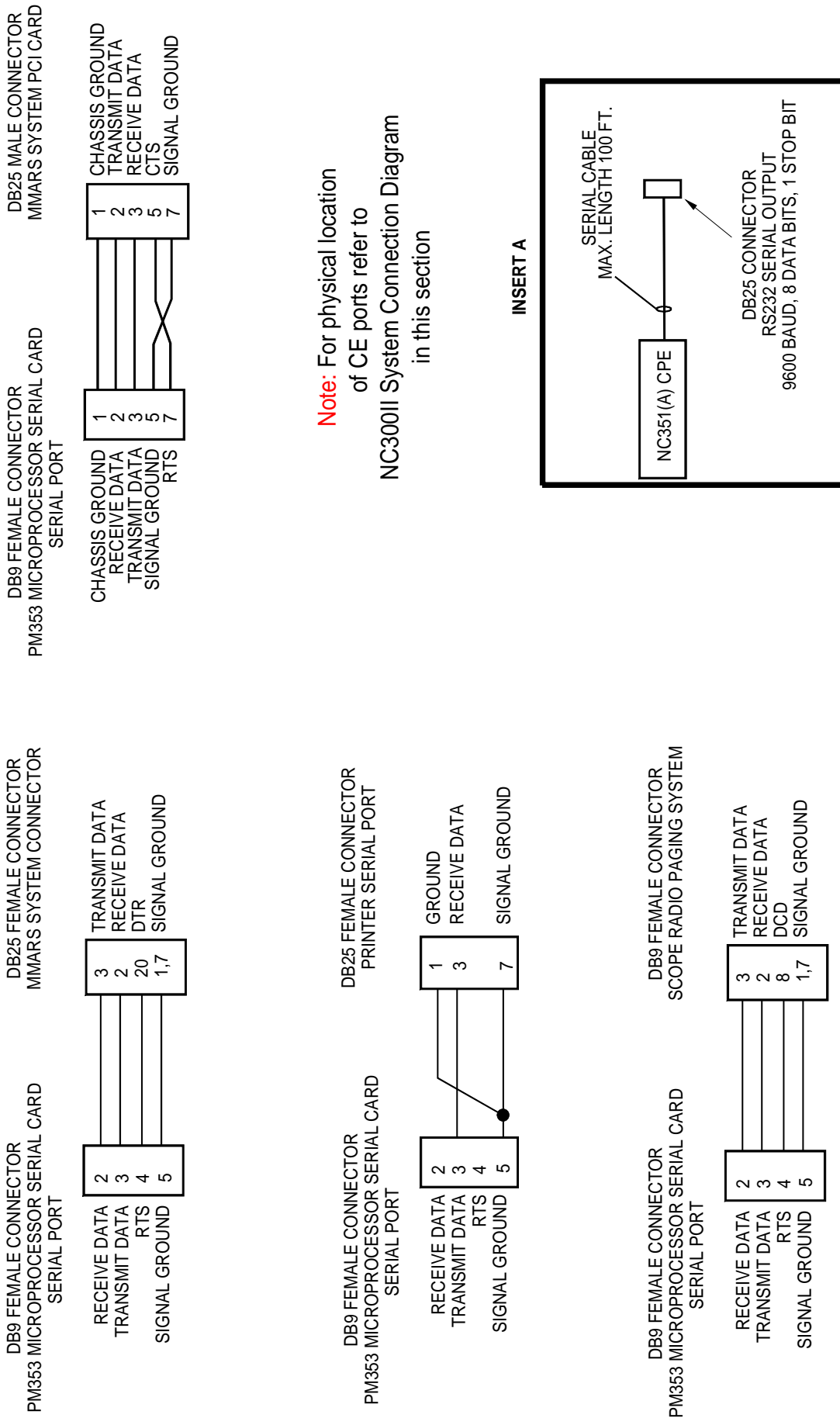

Drawing Name & Number: IL715 NC351(A) Serial Wiring Rev0 042004 1

Figure 40—NC351/2 Internal Hardware Diagram

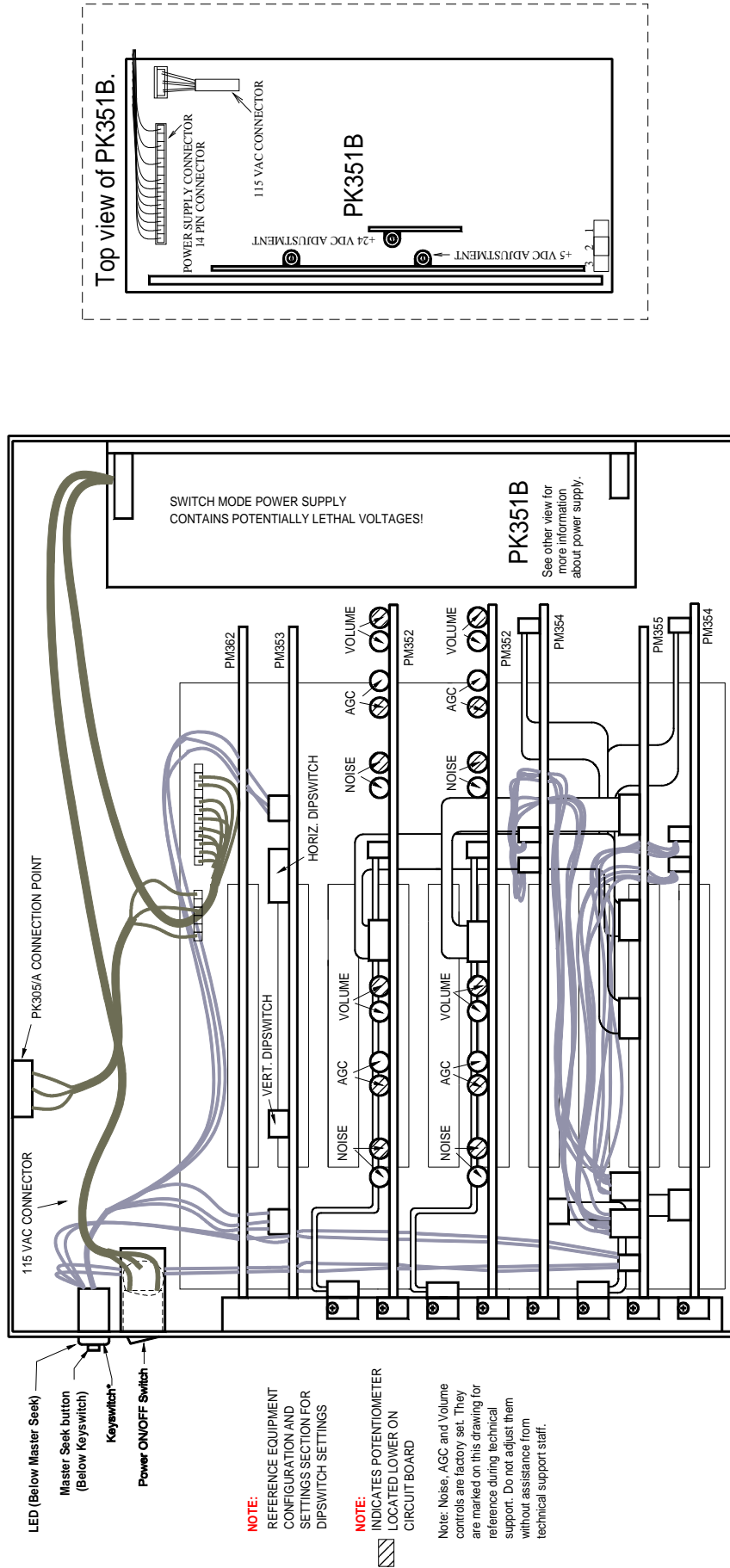

Drawing Name & Number: IL715 NC351 Internal Wiring Rev4 051204 1

Figure 40a—NC351(A)/2 Internal Hardware Diagram

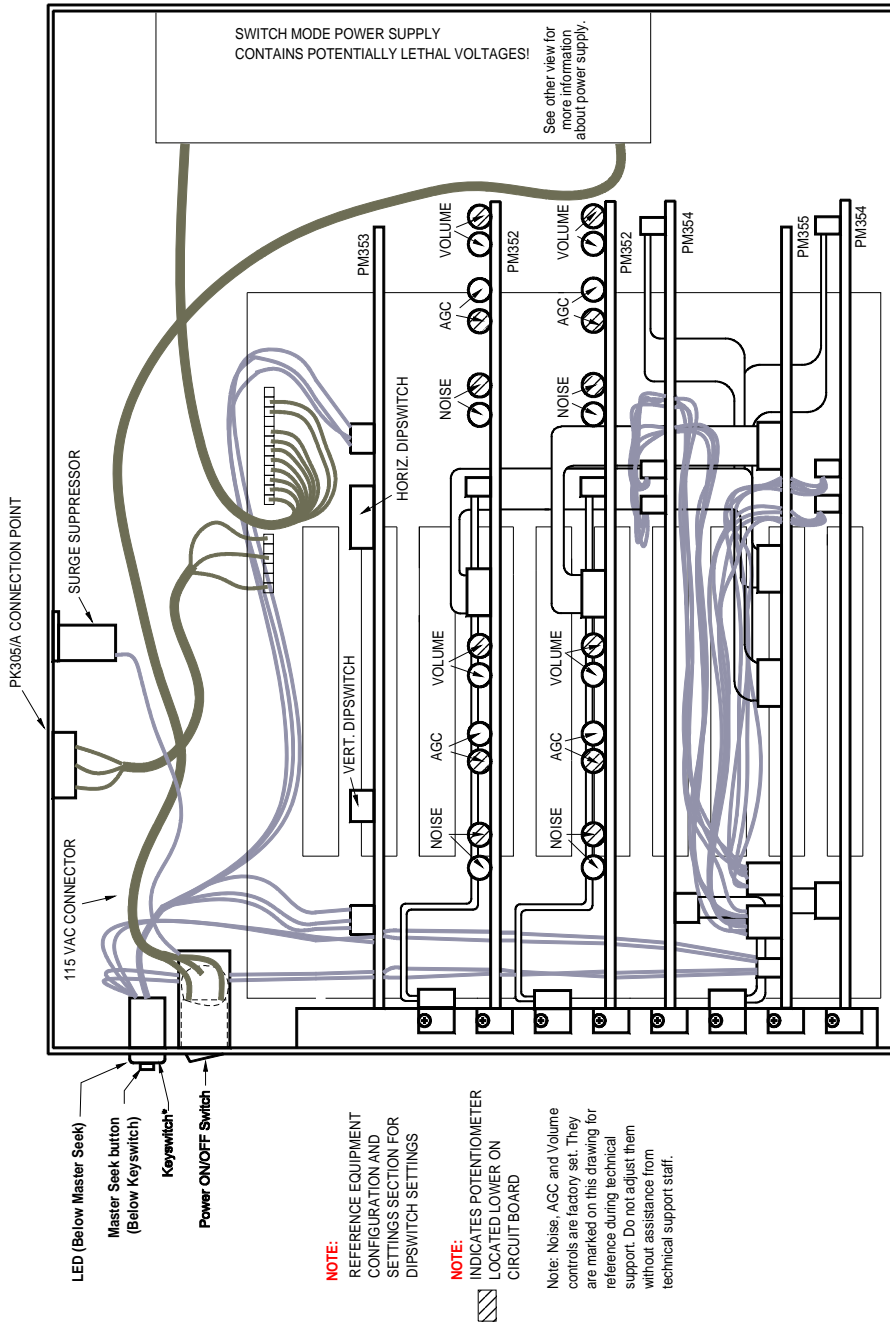

NOTES:

1. NC351A/2 EXPANDED SYSTEM SHOWN. NC351A STANDARD SYSTEM CONTAINS ONE PM352 CIRCUIT BOARD AND ONE PM354 CIRCUIT BOARD
2. KEYSWITCH USED TO ENABLE FIRMWARE REPROGRAMMING. TURN RIGHT (HORIZONTAL) TO ENABLE REPROGRAMMING. TURN LEFT (VERTICAL) FOR NORMAL OPERATION. FIRMWARE REPROGRAMMING SHOULD ONLY BE DONE UNDER THE DIRECTION OF THE SYSTEM ADMINISTRATOR!!!

Top view of PK357

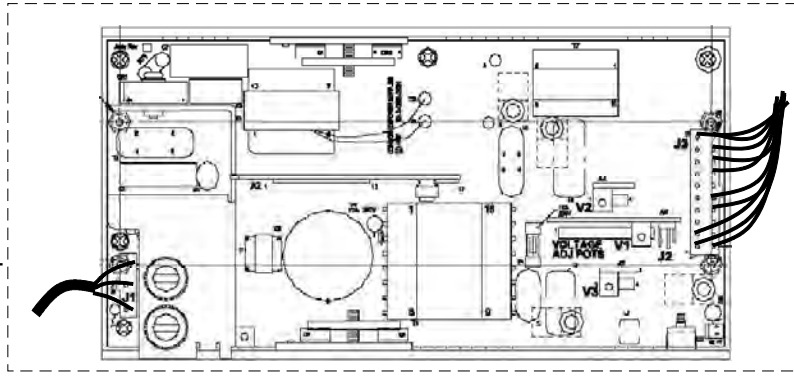

Drawing Name & Number: IL715 NC351A/2 Internal Wiring Rev2 082305 1

Figure 41—NC351(A)/2 Expanded System Exploded Internal Wiring Diagram

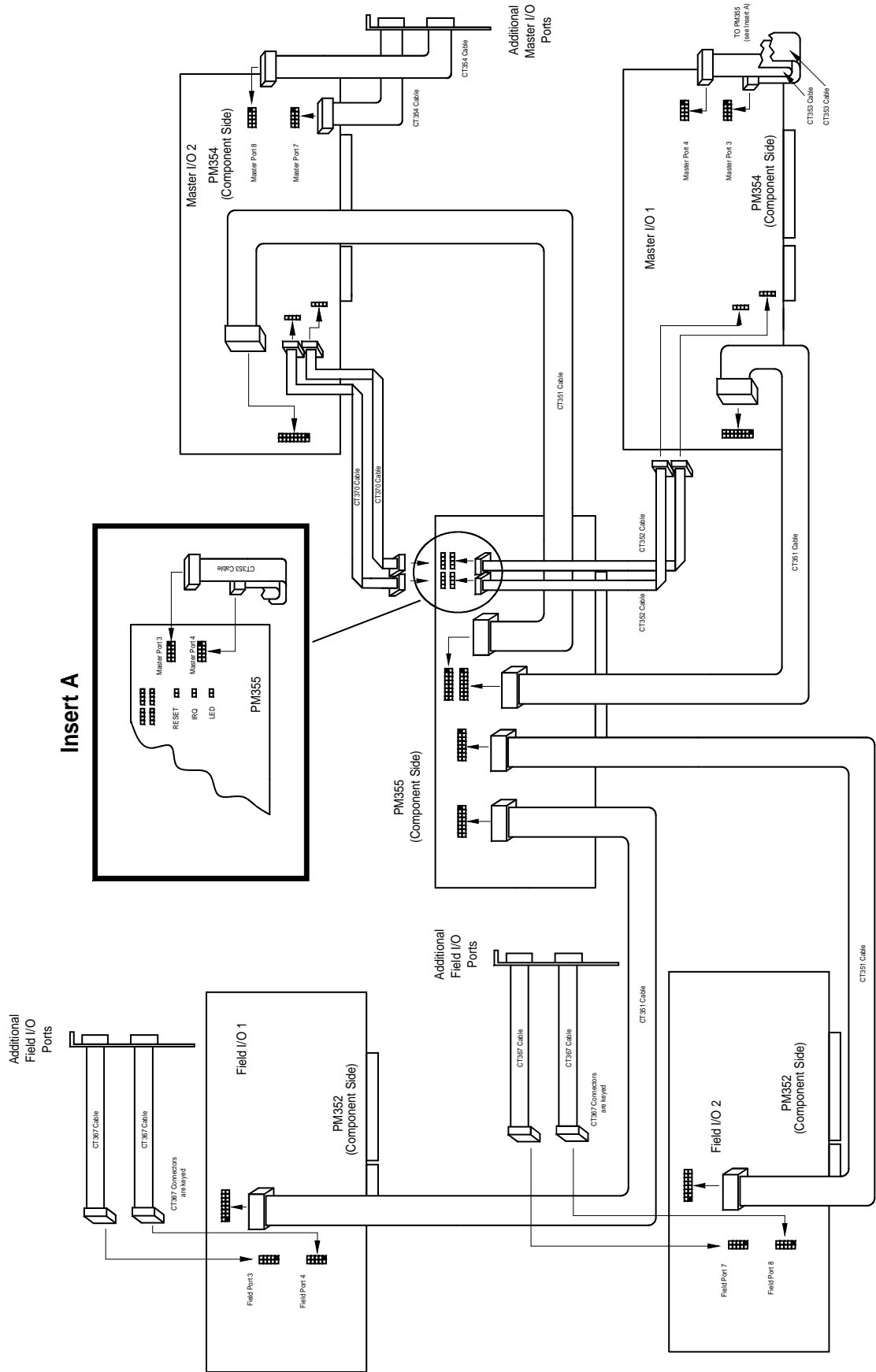

Drawing Name & Number: IL715 NC351(A)/2 Internal Wir Exploded Rev4 042004 1

Figure 42—PM352 and PM354 Jumper Settings

Field I/O # 1

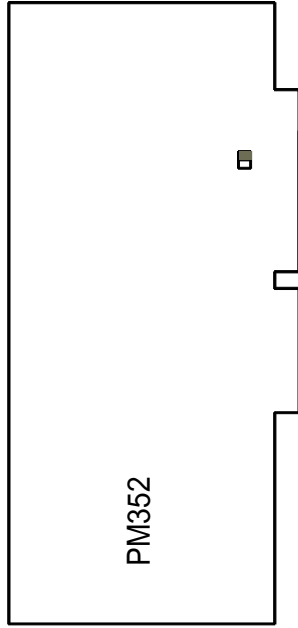

Field I/O # 2

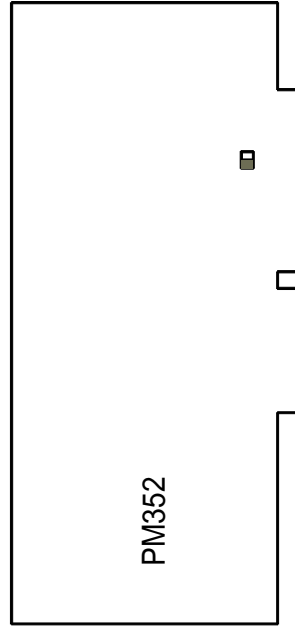

Master I/O # 1

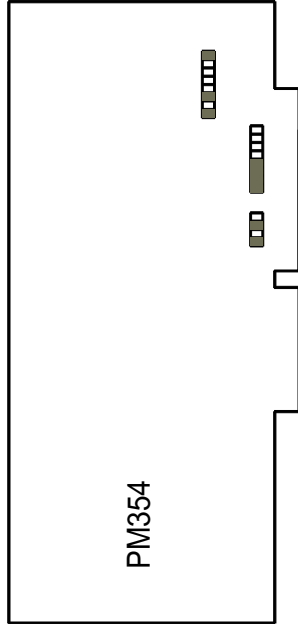

Master I/O # 2

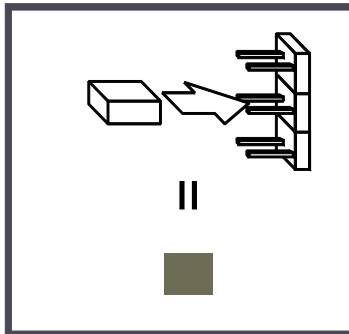
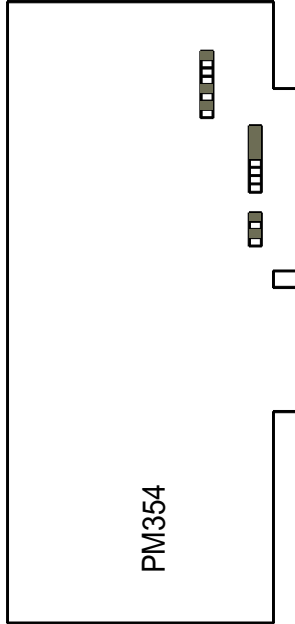

Drawing Name & Number: IL715 PM352 PM354 Card Settings Rev1 042302 1

Figure 43—SF380C Connections to Peripheral Devices

NOTE: To reduce drawing complexity, connections shown in drawing do not necessarily reflect physical placement or orientation!

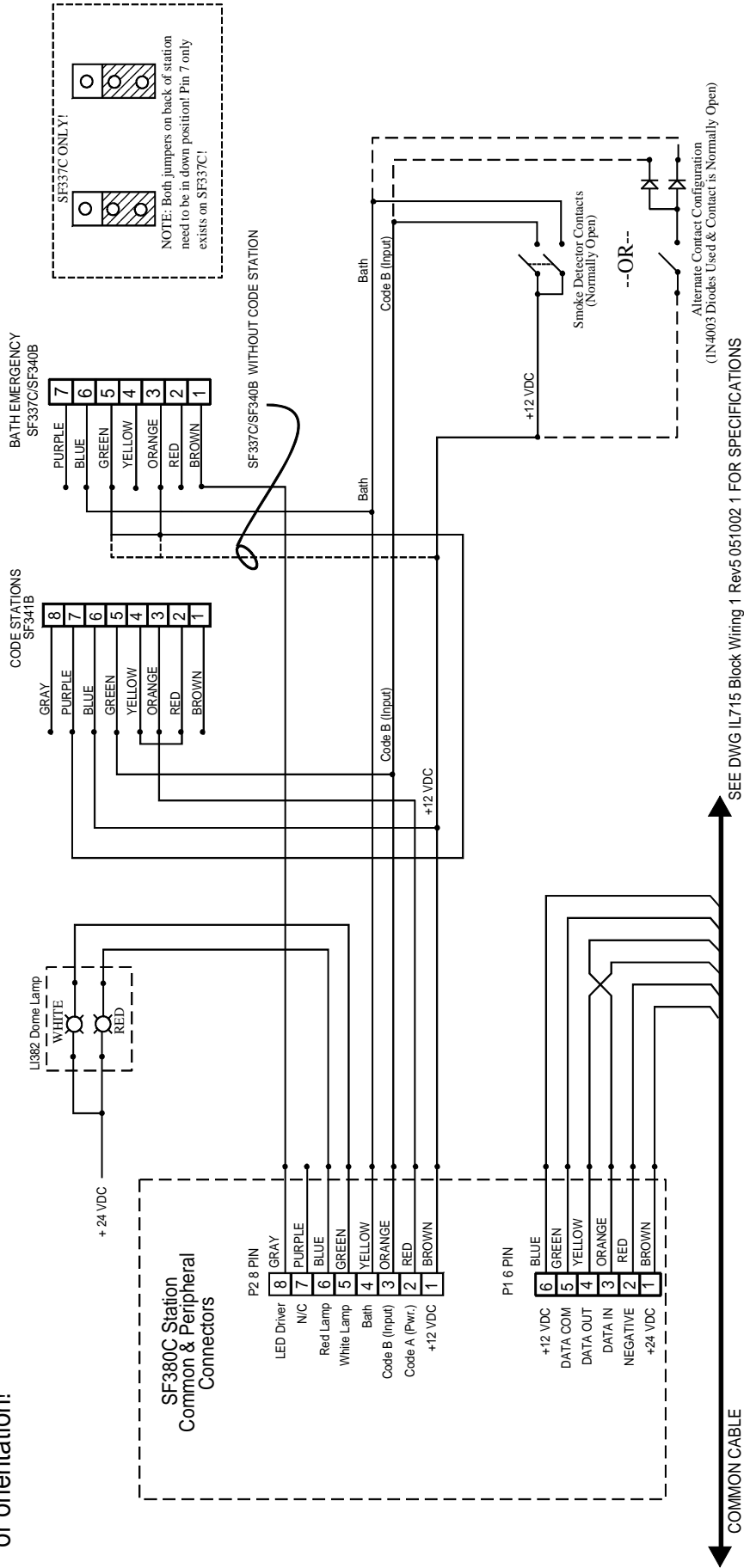

To NC351(A) (IL715) or NC350C (IL421) Series CE

NOTE: FIRE INDICATION AT THE NURSE MASTER IS SUPPLEMENTARY ONLY. THE TEK-CARE® NC300™ (IL421) or TEK-CARE® NC300™II (IL715) SYSTEM IS NOT INTENDED FOR USE AS A FIRE ALARM EVACUATION SYSTEM.

Drawing Name & Number: IL715 IL421 SF380C Wiring Rev5 042004 1

Figure 44—SF380P Connections to Peripheral Devices

NOTE: To reduce drawing complexity, connections shown in drawing do not necessarily reflect physical placement or orientation!

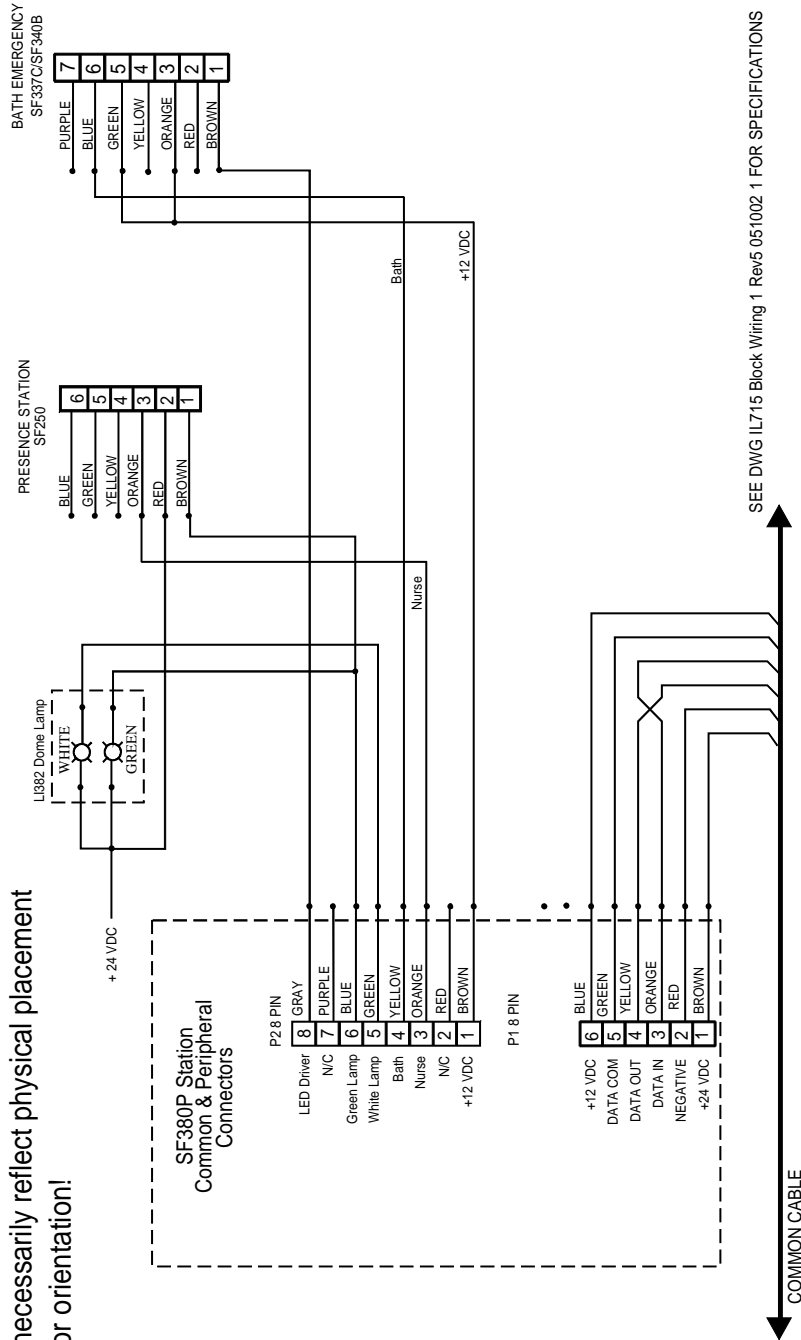

SEE DWG IL715 Block Wiring 1 Rev5 051002 1 FOR SPECIFICATIONS

To NC351(A) (IL715) or NC350C (IL421) Series CE

NOTE: FIRE INDICATION AT THE NURSE MASTER IS SUPPLEMENTARY ONLY. THE TEK-CARE® NC300™ (IL421) or TEK-CARE® NC300™II (IL715) SYSTEM IS NOT INTENDED FOR USE AS A FIRE ALARM EVACUATION SYSTEM.

Drawing Name & Number: IL715 IL421 SF380P Wiring Rev4 042004 1

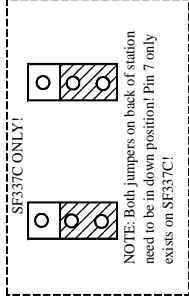

Dipswitch Settings

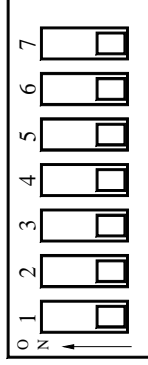

Switch "ON" = Value

1	=	1
2	=	2
3	=	4
4	=	8
5	=	16
6	=	32
7	=	not used

Figure 45—SF381/SF382 Wiring Diagram

NOTE: To reduce drawing complexity, connections shown in drawing do not necessarily reflect physical placement or orientation!

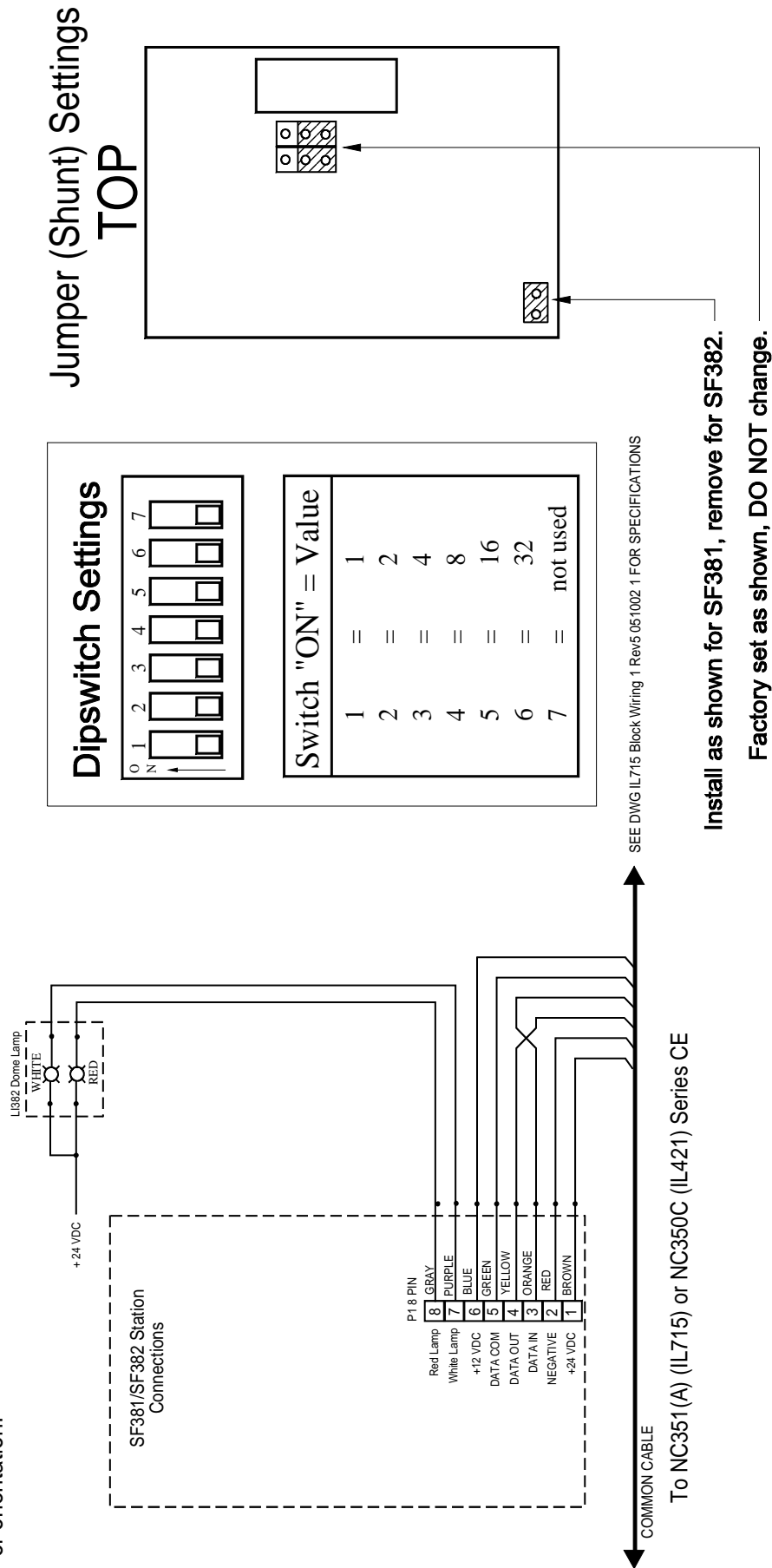

SEE DWG IL715 Block Wiring 1 Rev5 051002 1 FOR SPECIFICATIONS

**Install as shown for SF381, remove for SF382.
Factory set as shown, DO NOT change.**

Drawing Name & Number: IL715 IL421 SF381 SF382 Wiring Rev3 042004 1

Figure 46—Keypad for NC306

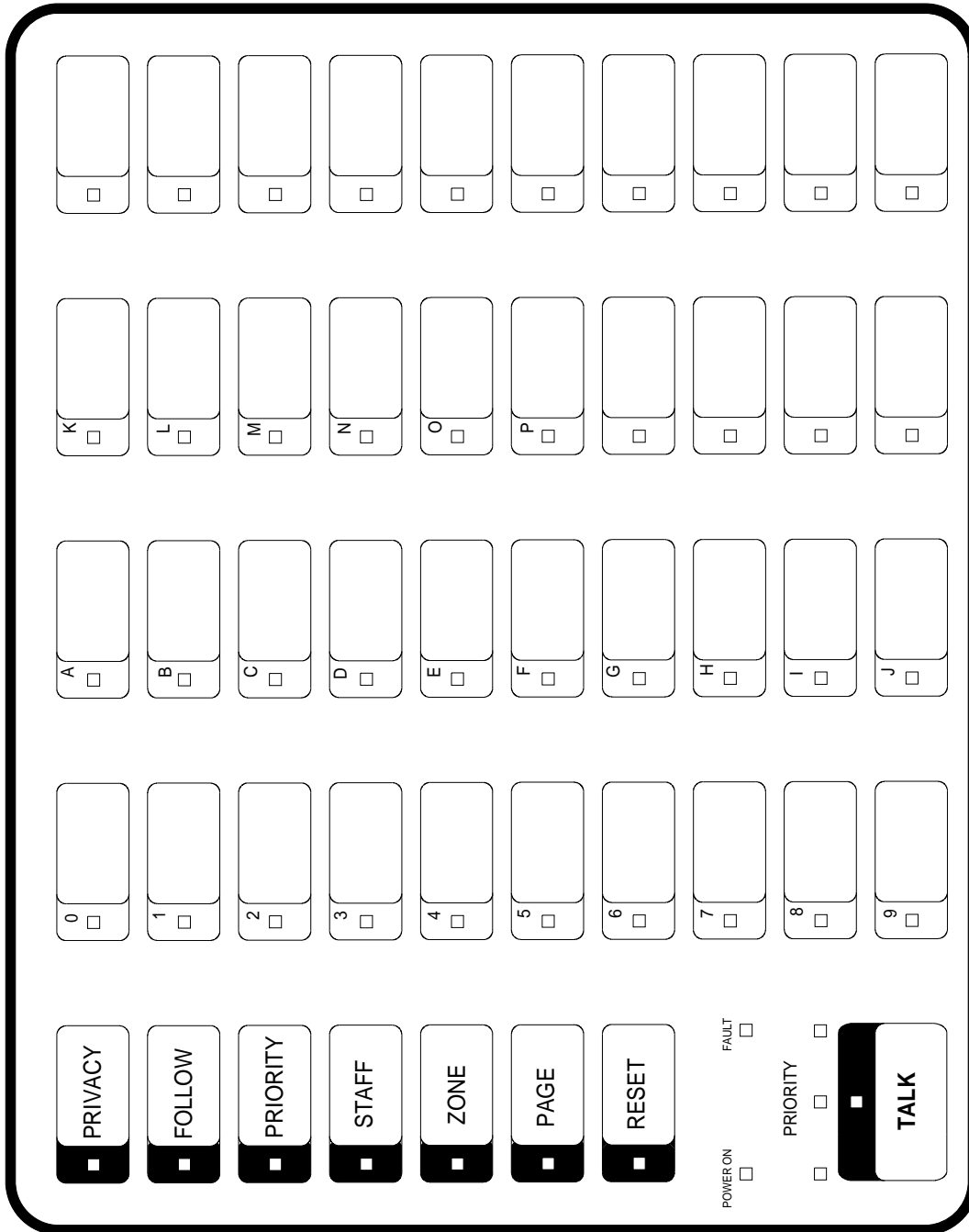

DRAWING#: IL715 ST097 K-P ZONES REV0 021302 2

Figure 47— SF380A Wiring Diagram

NOTE: To reduce drawing complexity, connections shown in drawing do not necessarily reflect physical placement or orientation!

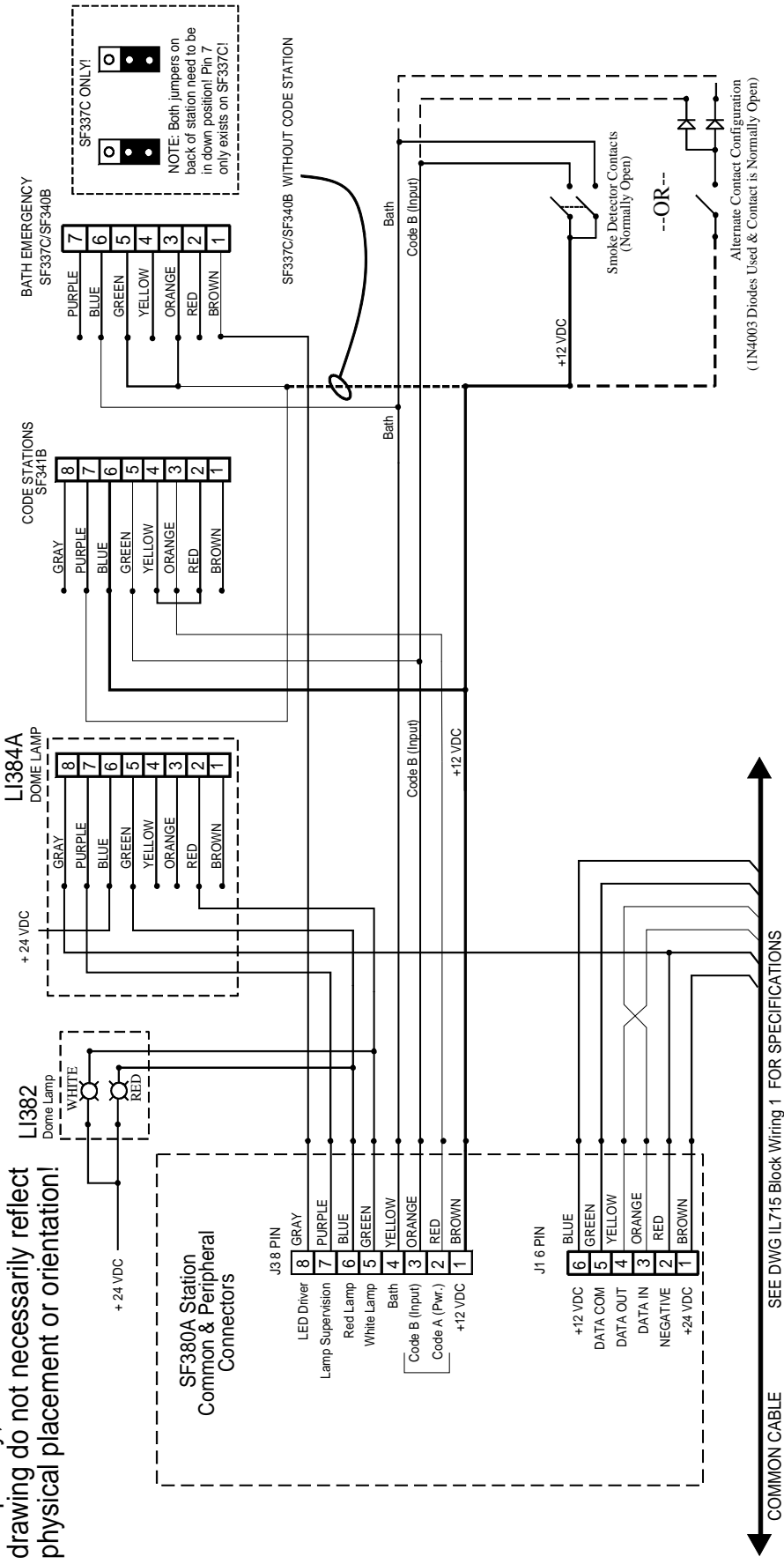

Dipswitch Settings

Switch "ON" = Value	Value
1	= 1
2	= 2
3	= 4
4	= 8
5	= 16
6	= 32
7	= See right



DIPSWITCH #7 SETTINGS
 ON = LAMP FAULT sensing ENABLED
 OFF = LAMP FAULT sensing DISABLED

To NC351(A) (IL715) or NC350C (IL421) Series CE

NOTE: FIRE INDICATION AT THE NURSE MASTER IS SUPPLEMENTARY ONLY. THE TEK-CARE® NURSE CALL SYSTEM IS NOT INTENDED FOR USE AS A FIRE ALARM EVACUATION SYSTEM.

COMMON CABLE SEE DWG IL715 Block Wiring 1 FOR SPECIFICATIONS

Drawing Name & Number: IL884 IL715 IL421 SF380A Wiring Rev2 01/28/09 1

Figure 48—LI484LED Wiring Diagram

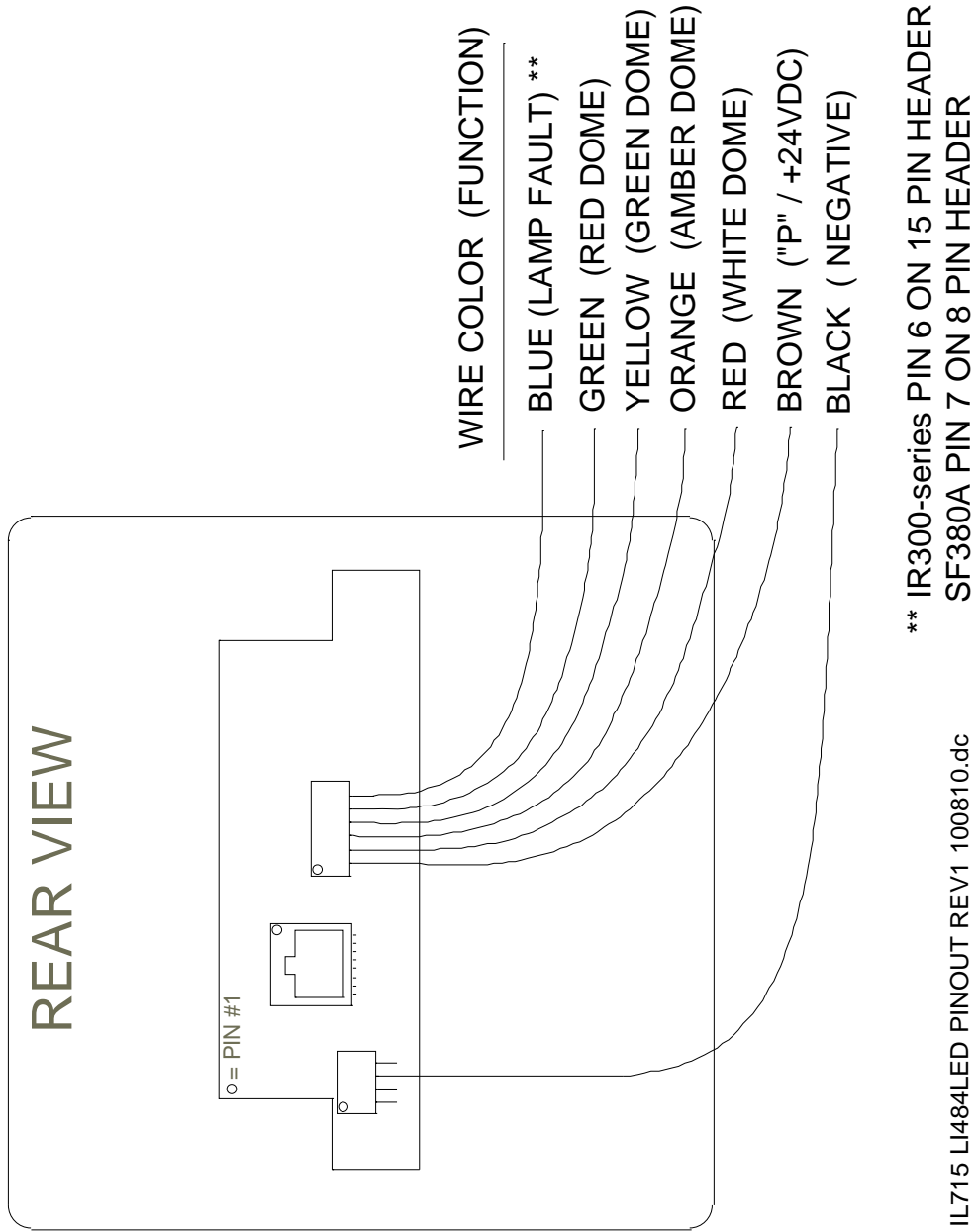

Figure 49—LI380 LED Wiring Diagram

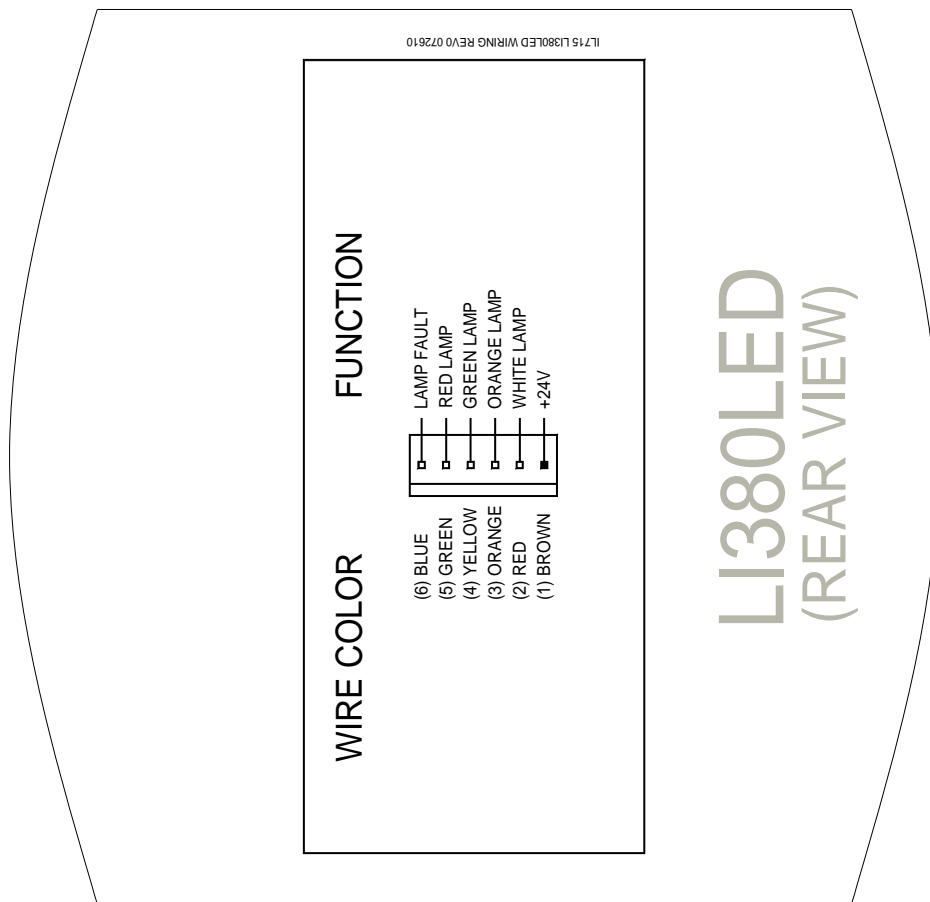

Figure 50—LI386LED Wiring Diagram

