



AdaptaBeacon® Heavy Duty Strobe Light

Portable

91B Series

FEATURES

- > Weatherproof
- > Battery operated (uses two 6V DC lantern batteries)
- > 65 flashes per minute
- > Xenon flash tube

www.leedan.com info@leedan.com Toll-Free: 800-231-1414

The Edwards 91B Series AdaptaBeacon heavy duty portable strobe lights are designed to maximize the strobe tube brilliance. This is accomplished with a series of complementing fresnels that cause the dome to "fill" with light each time the strobe flashes. This design feature increases the AdaptaBeacon "on-time", thus improving viewer perception. Beam distance is also increased with external fresnel lenses. The 91B Series' trigger and timing circuits are included as integral parts of the power supply. Replacement costs are reduced as it is necessary to replace only the strobe tube.

The 91B Series heavy duty portable strobes are ideal for use in identifying repair areas, temporary barriers, or emergency construction areas.

TECHNICAL INFORMATION

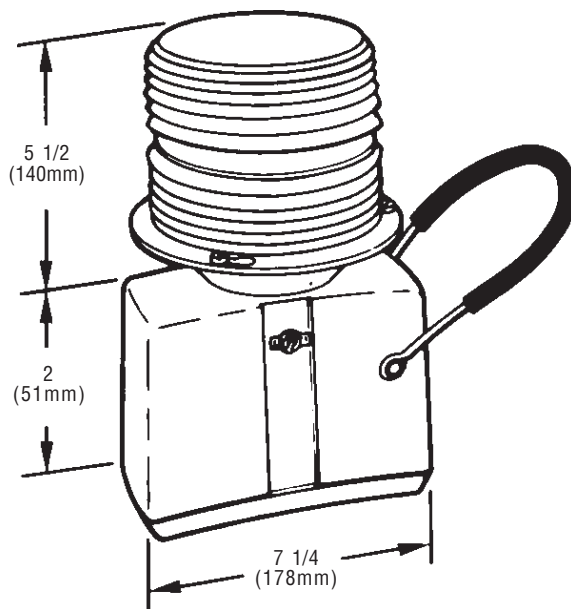

Cat. No.	Lens Color	Replacement Lens	Voltage	Peak Candlepower	Replacement Strobe Tube
91B-R	Red	93-LR	12V DC	300,000	91B-ST
91B-A	Amber	93-LA			300,000 cd*
91B-B	Blue	93-LB			3,000 hour**
91B-G	Green	93-LG			
91B-M	Magenta	93-LM			
91B-C	Clear	93-LC			

*Peak candela

**Calculated at operating power to 75% efficiency.

www.leedan.com info@leedan.com Toll-Free: 800-231-1414