



AdaptaBeacon[®] Light Duty Strobe

Weatherproof

90 Series

FEATURES

- > Weatherproof
- > Optically designed fresnel lens
- > Protective polycarbonate dome cover provides easy cleaning
- > Cast base can be utilized as a junction box
- > Immune to shock and vibration

AGENCY APPROVALS

- > UL 1638 Listed
- > CSA Certified C22.2 No. 205

www.leedan.com info@leedan.com Toll-Free: 800-231-1414

The Edwards 90 Series AdaptaBeacon Light Duty strobe lights are designed to maximize the strobe tube brilliance. This is accomplished with a series of complementing fresnels that cause the dome to "fill" with light each time the strobe flashes. This design feature increases the AdaptaBeacon "on-time", thus improving viewer perception.

The 90 Series' trigger and timing circuits are included as integral parts of the power supply. Replacement costs are reduced as it is necessary to replace only the strobe tube.

Designed for indoor or outdoor installation. May be direct, 1/2" (13mm) conduit, or box mounted on a 4" (102mm) octagon box on any plane. However, vertical installation ensures maximum beam width projection. For weatherproof installations units must be mounted vertically with dome up. May be corner mounted using the Cat. No. CBR, corner mount bracket, or wall mounted using the Cat. No. WBR, wall mount bracket. Cat. No. See AdaptaBeacon Accessories.

90 Series strobes are designed for light duty applications in industrial, commercial, and institutional applications where short term intermittent visual signaling is required. Ideally suited for installations where high ambient light levels make traditional rotating or flashing lights difficult to distinguish or where ambient noise levels make audible signals difficult to hear.

TECHNICAL INFORMATION

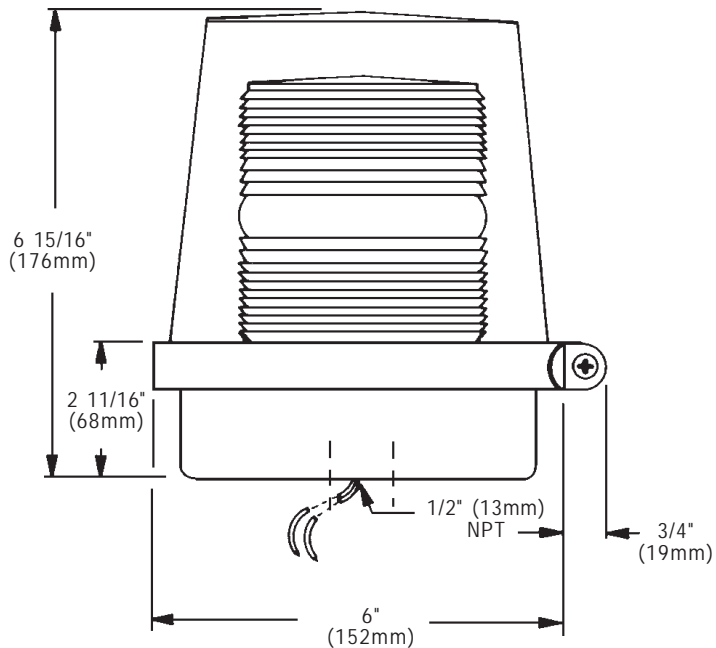

Cat. No.	Lens Color	Replacement Lens	Peak Candlepower	Electrical Ratings	Flash Rate	Replacement Dome	Replacement Strobe Tube
90R-N5	Red	92-LR	1,400	120V	65 fpm	52-LC	92-LST
90A-N5	Amber	92-LA		50/60 Hz			5,000 hours*
90B-N5	Blue	92-LB		0.1 Amps			
90G-N5	Green	92-LG					
90M-N5	Magenta	92-LM					
90C-N5	Clear	92-LC					

*Calculated at operating power to 75% efficiency.

www.leedan.com info@leedan.com Toll-Free: 800-231-1414