



AdaptaBeacon® Flashing Light

*Weatherproof
Protective Dome*

49 Series

FEATURES

- > 40 Watt Halogen Lamp in 120V AC Model
- > Weatherproof
- > Protective polycarbonate dome for easy cleaning
- > Cast base can be utilized as junction box

AGENCY APPROVALS

- > UL 1638 Listed
- > CSA Certified C22.2 No. 205

www.leedan.com info@leedan.com Toll-Free: 800-231-1414

The Edwards 49 Series AdaptaBeacon flashing lights are designed to provide a bright visual indication utilizing special optics within a shatter resistant polycarbonate lens. The polycarbonate double fresnel lens ensures efficient light dispersion. This is accomplished with a series of complementing fresnels that cause the dome to "fill" when the light is operating. Beam distance is also increased with fresnel lenses. Lenses are available in six colors: red, amber, blue, green, magenta, and clear

Designed for indoor or outdoor installation. May be direct, 1/2" (13mm) conduit, or box mounted on a 4" (102mm) octagon box. For weatherproof installation, units must be mounted vertically with lens facing up. May be corner mounted using the Cat. No. CBR, corner mount bracket, or wall mounted using the Cat. No. WBR, wall mount bracket. See Adaptabeacon Accessories.

Edwards flashing lights are particularly effective in high noise level areas, especially where ear protection must be worn and audible signals may not be heard or understood. They can advise personnel in manufacturing and process areas when an operation is starting or stopping. Often used to signal malfunctions in equipment, such as assembly line jams. Can warn personnel that they are entering a restricted area or an area of high danger.

TECHNICAL INFORMATION

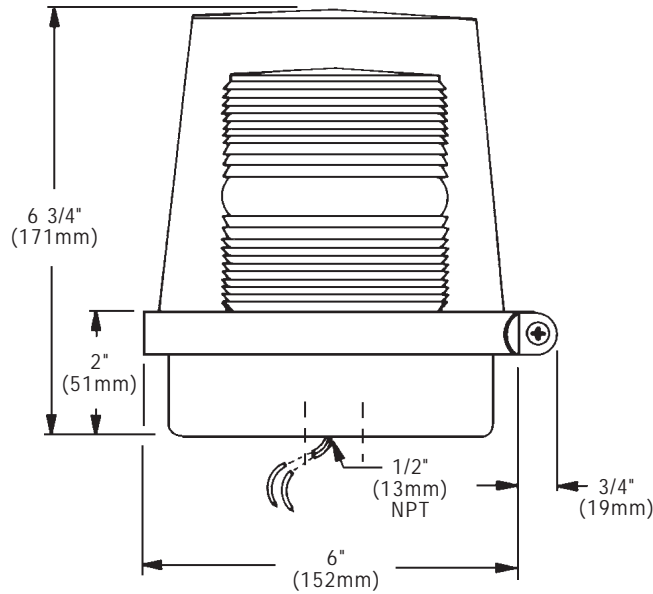

Cat. No.	Lens Color	Repl. Lens	Repl. Dome	Lamp Ratings	Replacement Flasher	Electrical Ratings	Replacement Lamp
49R-N5-40WH	Red	92-LR	52-LC	40 watts	P-041917-0026	120V 50/60 Hz	50LMP-40WH
49A-N5-40WH	Amber	92-LA		265 lumens*		0.30 Amps	
49B-N5-40WH	Blue	92-LB		3328 candlepower			
49G-N5-40WH	Green	92-LG		25,000 hours**			
49M-N5-40WH	Magenta	92-LM					
49C-N5-40WH	Clear	92-LC					
49R-R5	Red	92-LR	52-LC	25 watts	P-041917-0038	240V 50/60 Hz	P-041917-0039
49A-R5	Amber	92-LA		232 lumens*		0.10 Amps	or Industry Trade
49B-R5	Blue	92-LB		2914 candlepower			No. 25T8/240V/DC/CL
49G-R5	Green	92-LG		120 hours**			
49M-R5	Magenta	92-LM					
49C-R5	Clear	92-LC					

*Bulb manufacturer's lumen rating

**Projected lamp life based on manufacturer's calculated long life at 65 FPM and 50% duty cycle.

www.leedan.com info@leedan.com Toll-Free: 800-231-1414