



6500 VEHICULAR SWING GATE OPERATOR



easy access
case design



breakaway
hub prevents gearbox damage



simple
manual release



steel frame
belt driven

- Split polyurethane housing allows easy access without having to remove the gate arm!
- Easy to adjust electronic magnetic limits eliminate old style mechanical switches that can wear out, break or fail
- Unique breakaway hub design prevents gear box damage if the gate is struck
- Steel frame for strength and durability
- Belt driven gear box for quiet operation
- Easy to use manual release system
- Advanced microprocessor control board features programming switches to set the mode of operation required and has ports for DKS plug-in loop detectors
- Easy bi-parting (dual) gate system connection from one circuit board
- 5-year limited warranty

FEATURES

ACCESS CONTROL SOLUTIONS





6500 VEHICULAR SWING GATE OPERATOR

The DKS 6500 swing gate operator is designed for residential, commercial and industrial applications for both single and dual-leaf gates. The unique design of this operator allows for easy access to the electronics and mechanical areas of the operator without ever having to remove the gate arm. This simplifies installation and maintenance. The electronic magnetic limits will never wear out or break and they are easily adjusted. The solid steel frame and belt driven gear box make this operator one of the quietest vehicular gate operators on the market today.

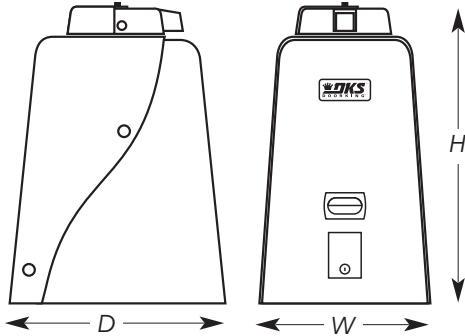

6500 1/2 & 1 HP
 18.375" W x 31.675" H x 23.25" D
 (466.7 mm W x 804.5 mm H x 590.5 mm D)

6500 1/2 HP Specs

Class of operation	Max Gate Length *	Max Gate Weight *	HP	Power	Convenience Open Package
I, II, III, IV	18 Ft (5.48 m)	700 Lbs. (317.5 kg)	1/2HP 60 cycles/hr continuous duty	115 VAC, 60 Hz, 5.4A 208/230 VAC, 60 Hz, 2.7A** 460 VAC, 60 Hz, 1.4A**	Optional †

6500 1 HP Specs

Class of operation	Max Gate Length *	Max Gate Weight *	HP	Power	Convenience Open Package
I, II, III, IV	22 Ft (6.7 m)	800 Lbs. (362.8 kg)	1HP 60 cycles/hr continuous duty	115 VAC, 60 Hz, 9.7A 208/230 VAC, 60 Hz, 4.9A** 460 VAC, 60 Hz, 2.5A**	Optional †

* Assumes gate to be in good condition and swinging in a level plane.
 When combined with convenience open option, 1/2HP max weight is 500 Lbs., and 600 Lbs. with 1HP.
 ** These operators use a step-down transformer to achieve 115 VAC operating voltage.
 † Optional factory installed DC powered drive system provides an automatic method to open a gate when primary (AC) power fails.

General Specs

Mechanical

Primary Reduction: Pulley / belt driving a worm gear running in a continuous oil bath
 Speed: Rotates gate 90° in approximately 12-14 seconds
 Frame: Steel frame plated for corrosion resistance
 Arm: Articulating arms to allow mechanical slow start / slow stop function.
 Mounting: Pad mount

Manual Release

Keyed access to arm release

Safety Standards

Compliant with UL 325 and UL 991 safety standards

Advanced Features

Adjustable electronic magnetic limits
 Auto-close timer (1-23 seconds)
 Gate overlap feature for bi-parting (dual) gate operation
 Simple connection for secondary operator in bi-parting gate systems
 Built-in On / Off switch
 Built-in alarm reset switch
 Selectable shadow / reverse loop function
 Magnetic lock power
 Ports for plug-in open and reverse loop detectors. DKS plug-in detectors only
 Three 115 VAC convenience outlets for accessory transformers
 Gate Tracker reporting output provides operator data to access control system (DKS systems with card access only)
 Split polyurethane housing simplifies installation and maintenance. No need to remove the gate arm
 Unique breakaway hub protects the gear box if the gate is rammed

Operating Temp

10°F to 115°F
 -12°C to 46°C
 Heater kit recommended for colder environments

Shipping Weight

Approximately 175-225 Lbs (79.1-101.8 kg)
 Depending on model and options selected

Warranty

5-year limited warranty

DOORKING®, INC.

© 2008 All Rights Reserved. Product specifications may change without notice. Rev. 1/08

MEMBER:



Distributed by:
LEE DAN COMMUNICATIONS, INC.
www.leedan.com
info@leedan.com
Toll-Free: 800-231-1414