

LEF-3L

3-Call Master Station with Selective Control Capability (Door Release or Camera Call-up)

Used with LE-D, LE-DA, LE-DL, LS-NVP/B Door Stations

- SUPPLEMENT TO LEF INSTRUCTIONS -

The LEF-3L is a compact, wall or desk mount master station able to selectively release a door or call up a camera. Used with any LE- or LS-series remote station, communication can be established with each station by selecting the channel on the master station. While the channel is selected, pressing the door release button (left of TALK button) will release only the associated door. When used for camera call-up, a relay closure will be maintained as long as a station is selected. The system can have up to four stations, in any combination of masters or door stations (e.g. 2 masters and 2 doors). Master-to-master communication is also a standard feature.

(If communication between masters is not required, multiple LEF-3L's can be used to talk to 3 door stations.)

1 NAMES & FEATURES

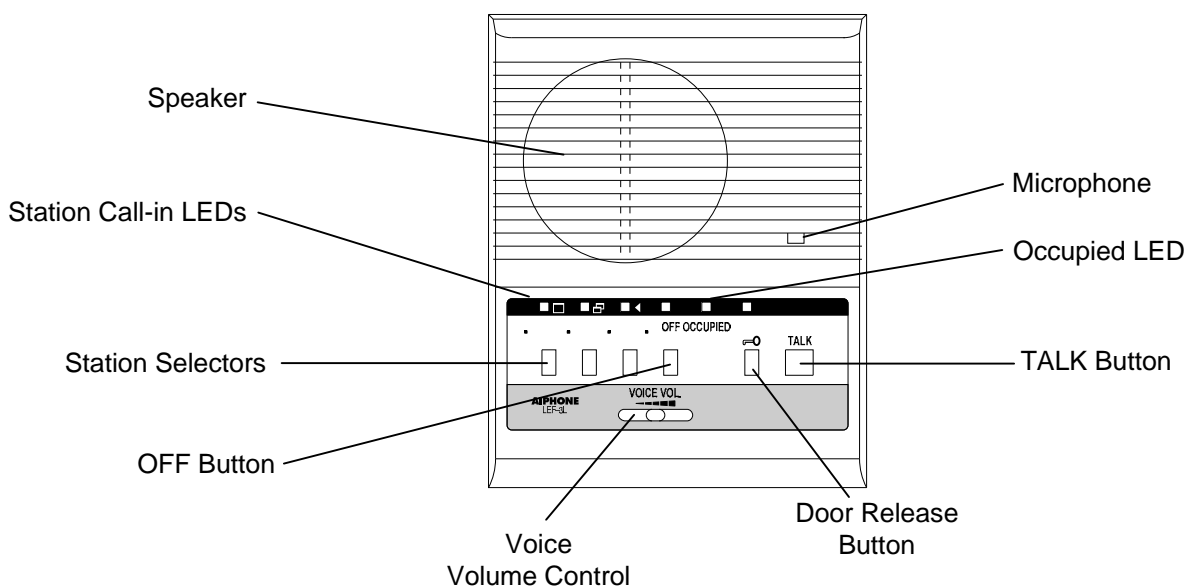

FEATURES:

- Selective door release control
- CCTV camera call-up capability
- Single or multiple masters can be used in a system
- Master to master communication in a multi-master system
- Single talkpath, with push-to-talk operation at master, and hands free communication at sub station
- Large variety of sub stations available
 - Surface or flush mount, with or without privacy (LE-A, LE-AN, LE-B, LE-BN)
 - Weather resistant door stations (LE-D, LE-DA, LE-DL)
 - Vandal proof sub stations (LE-SS, LE-SSR & LS-NVP/B)
- Subs call in with momentary tone and LED, remaining lit for approximately 20 seconds
- Selective calling to sub stations

Individual Components for LEF-3L System:

LEF-3L	3-call master with selective door release
LE-D	Surface mount door station
LE-DA	Flush mount door station with stainless steel faceplate
LS-NVP/B	Vandal and weather resistant sub station, white powder coated (optional SBX-NVP surface box)
LE-SS	Stainless Steel 2-Gang sub station
LE-SSR	Stainless Steel 2-Gang sub station with red mushroom push button
SBX-2G	Surface mount box for LE-SS and LE-SSR
LE-SS-1G	Stainless Steel 1-Gang sub station (optional SBX-SS-1G surface box)
SA-1	Surge Arrestor (1 per 2 wires being protected)
RY-PA	Relay, 12V DC input, N/O dry closure output. One required for each contact closure required off of each channel. Can be momentary or maintained, according to wiring.
RY-18L	12-18V DC "Form C" relay (N/O and N/C contacts)
PS-1225UL	12V DC , 2.5A power supply, use for intercom only, 1 per system

LEF-3L TERMINAL DEFINITIONS:

+	Positive 12V DC	12V DC VOLTAGE ONLY.
-	Negative	AC VOLTAGE WILL DAMAGE THE UNIT.
1~3	Station number, communication to sub or other master	
C	"CALL", for receiving a call from another master station	
E	Common communication	
R	Occupied light control (0V DC when system is occupied)	
Y	All Call override control (Not used in LEF-3L system)	

LE-D/LE-DA TERMINAL DEFINITIONS:

1	Station number
E	Common communication
-	Negative

LS-NVP/B TERMINAL DEFINITIONS:

Red	Station number
Black	Common communication
Green	Negative

COLOR-CODED WIRES:

White	Common Door release activation (+12V DC when door release button is pressed)
Brown	Ground when station 1 is pressed
Red	Ground when station 2 is pressed
Orange	Ground when station 3 is pressed

LE-SS(R)/LE-SS-1G Color Code:

Red	Station number
Black	Common communication
Green	Negative

WIRING & INSTALLATION:

Before Installation:

- Make sure you have the proper power supply(ies) and all necessary and compatible equipment for the system.
- Lay out your system in advance, assigning station numbers for all sub station locations.
- Surge protection for the intercom equipment is recommended. Add SA-1 surge arrestors for the power supply, plus one per two wires connected to the master station.

Wire:

- **Shielded wire is strongly recommended.** Use the proper gauge for the distance being run.
- Wiring between masters must be a multi-conductor cable. If more than one cable is used to connect masters, the "E", "C", and number terminal wires must be in the same jacketed cable. If necessary, run multiple "E" wires, one in each cable.

Wiring Method:

- Run intercom cables at least 20" away from all AC wiring, fluorescent lights, dimmer switches, and other electrical or electronic devices. Intercom wiring can cross AC wires at 90 degrees.
- Sub stations can be homerun to the nearest master station, or daisy-chained. If daisy-chained, include 2 common wires plus 1 individual wire per station on the run.
- In a SINGLE MASTER SYSTEM ONLY: Subs can be wired with 2 conductors homerun. Jumpers between "E" and "-" must be attached on all subs and at the master station.

Intercom Locations:

- Do not install intercoms near dimmer or light switches, or other electrical wall devices.
- To prevent feedback, do not place sub stations back-to-back on a common wall.

3 WIRING DIAGRAMS - Most Common Applications

DISTRIBUTED BY:
www.leedan.com info@leedan.com Toll-Free: 800-231-1414

1 LEF-3L, 3 Door Stations - With Selective Door Release

IMPORTANT: When using selective outputs, a separate relay and power source are required. Do not power external devices off of the system power supply.

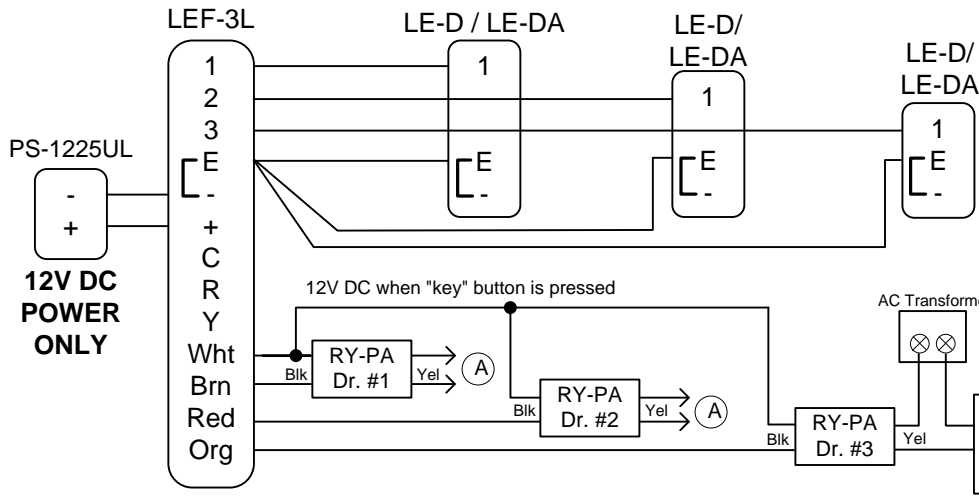

NOTE:
 When running 2 conductors homerun to each sub (single master system only), leave jumper attached between E & - on master and door stations. Otherwise, remove jumpers and use separate wires for E and - terminals.

(A) Momentary dry closure when station is selected and "key" button is pressed. Connect to door strike & power.

2 LEF-3L, 2 Door Stations

With Master-to-Master communication shown on channel 3
 With Selective Door Release

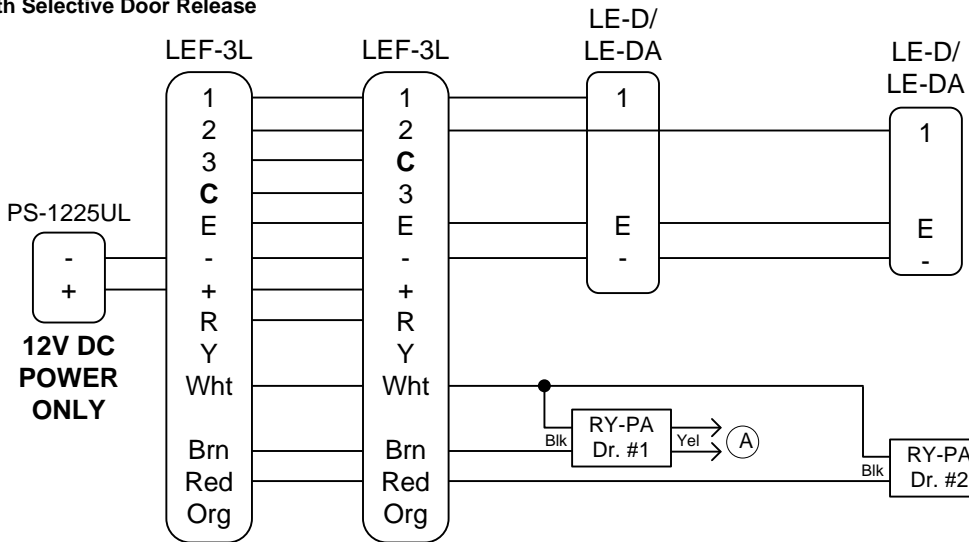

(A) Momentary dry closure when station is selected and "key" button is pressed. Connect to door strike & power.

3 LEF-3L, 1 Door Station

With Master to Master Communication

Door Station wired on each station's own number terminal (different on each master)

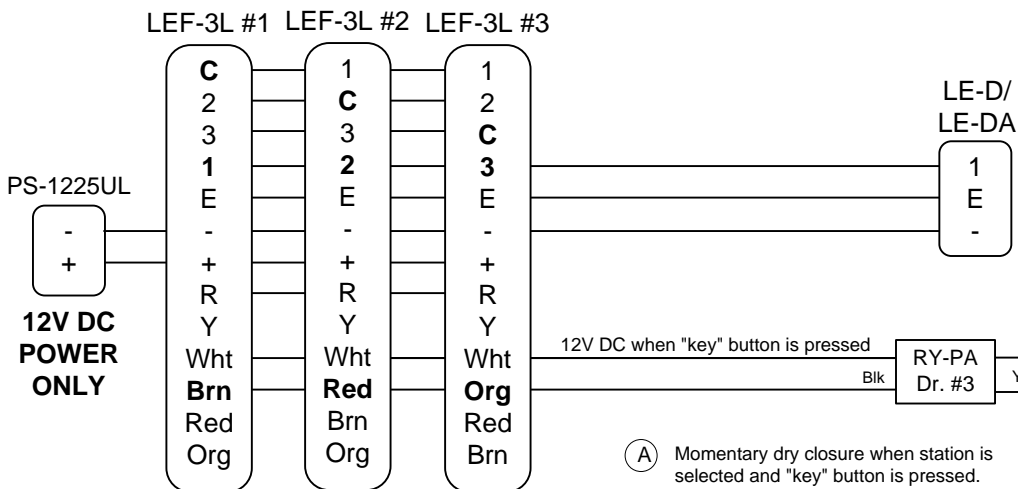

(A) Momentary dry closure when station is selected and "key" button is pressed. Connect to door strike & power.

Optional Remote station:

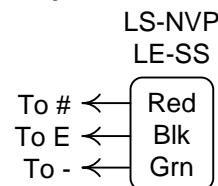

3 WIRING DIAGRAMS - Multiple Masters for Door Answering Only

DISTRIBUTED BY:
www.leedan.com info@leedan.com Toll-Free: 800-231-1414

2 LEF-3L, 3 Door Stations - No Master-to-Master Communication

Shown with door release relays

IMPORTANT: When using selective outputs, a separate relay and power source are required. Do not power external devices off of the system power supply.

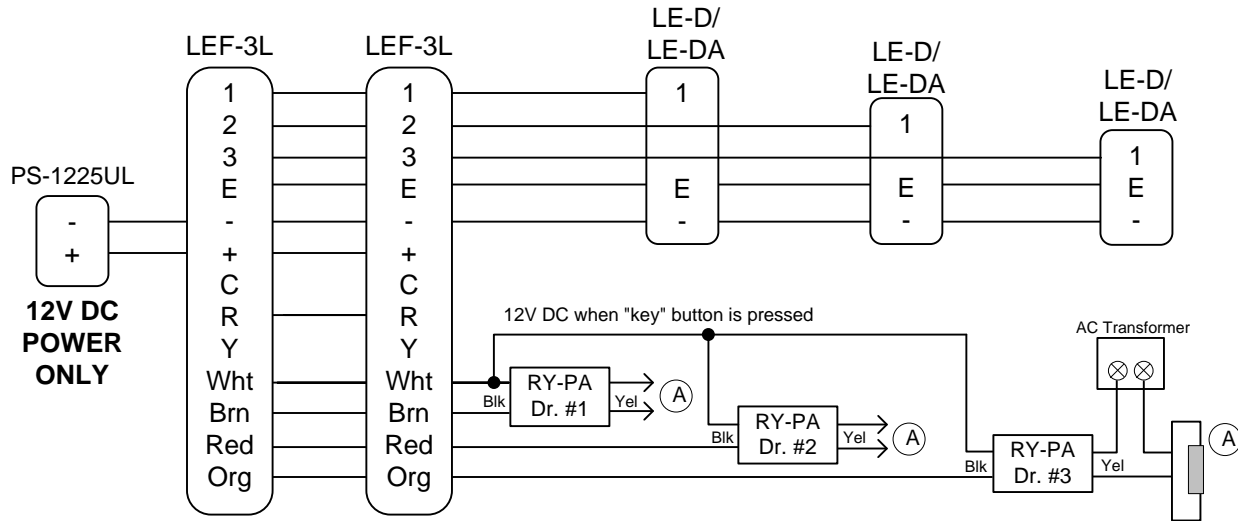

(A) Momentary dry closure when station is selected and "key" button is pressed. Connect to door strike & power.

Multiple LEF-3L's (max. 10) and 2 Door Stations No Master-to-Master Communication

Shown with 5 masters, 2 doors. Connect up to 10 masters in parallel as shown, and up to 3 door stations.

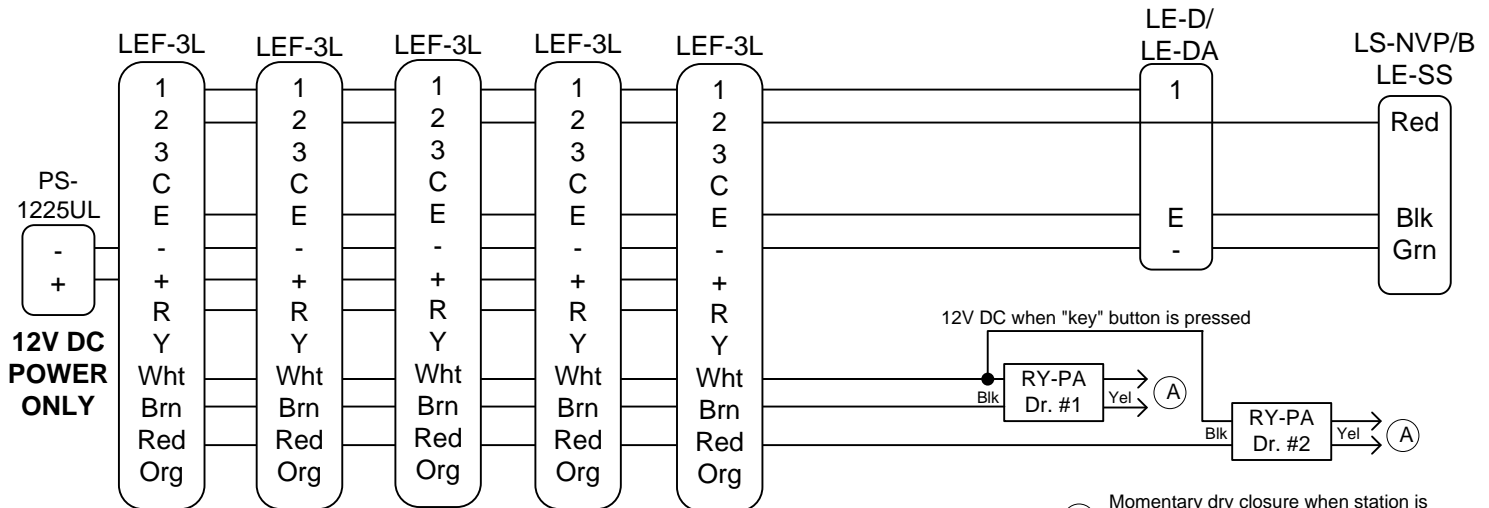

(A) Momentary dry closure when station is selected and "key" button is pressed. Connect to door strike & power.

LEF-3L System with External Signaling (RY-AC)

One door station with the ability to activate a separate doorbell
 Shown with external signaling and door release relays

IMPORTANT: When using selective outputs, a separate relay and power source are required. Do not power external devices off of the system power supply.

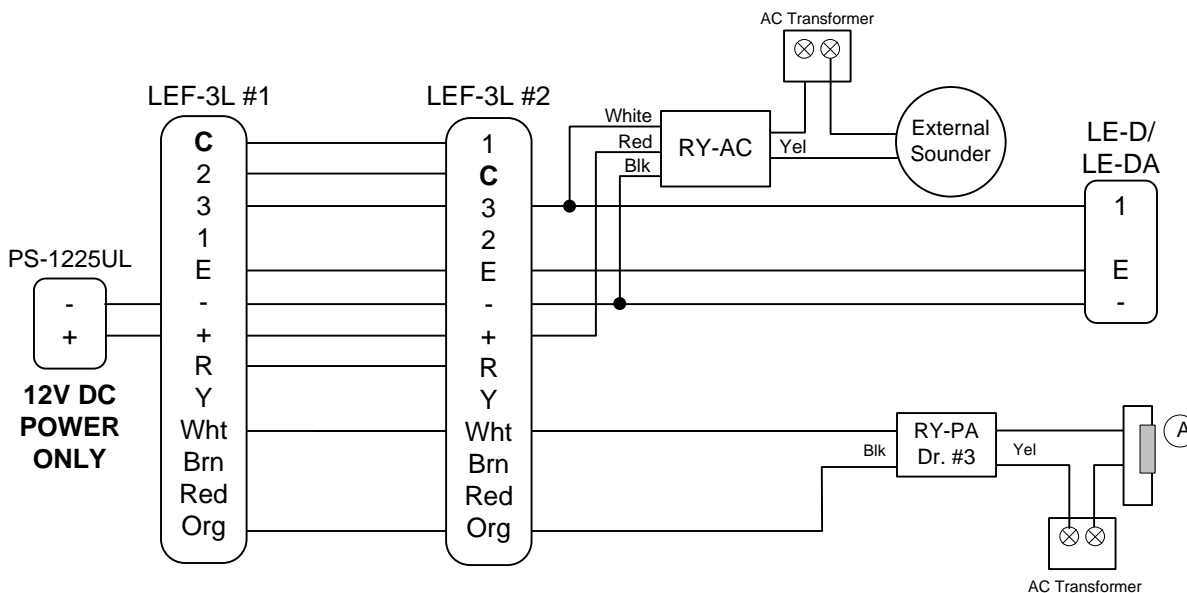

LEF-3L System with External Signaling (RY-AC)

Selective external signaling relay outputs for each door station call-in

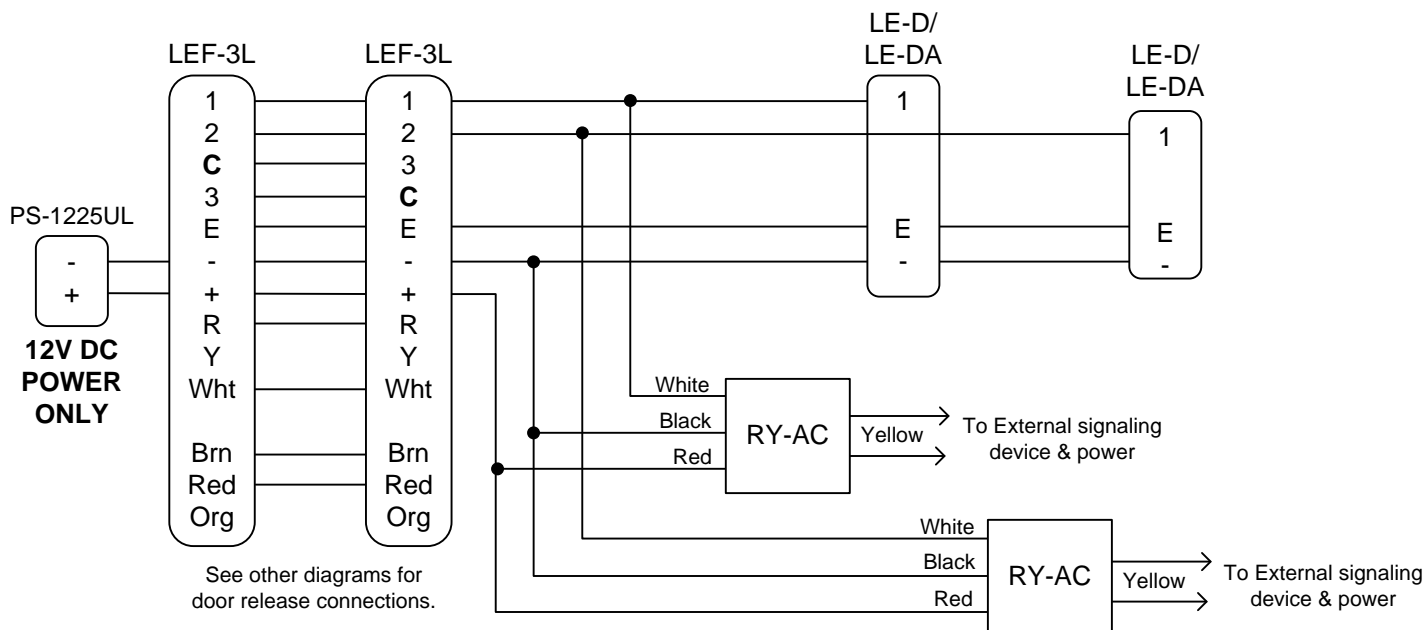

1 LEF-3L, 2 Door Stations -

Shown with both Door Release and CCTV Camera Call-up relays

IMPORTANT: When using selective outputs, a separate relay and power source are required. Do not power external devices off of the system power supply.

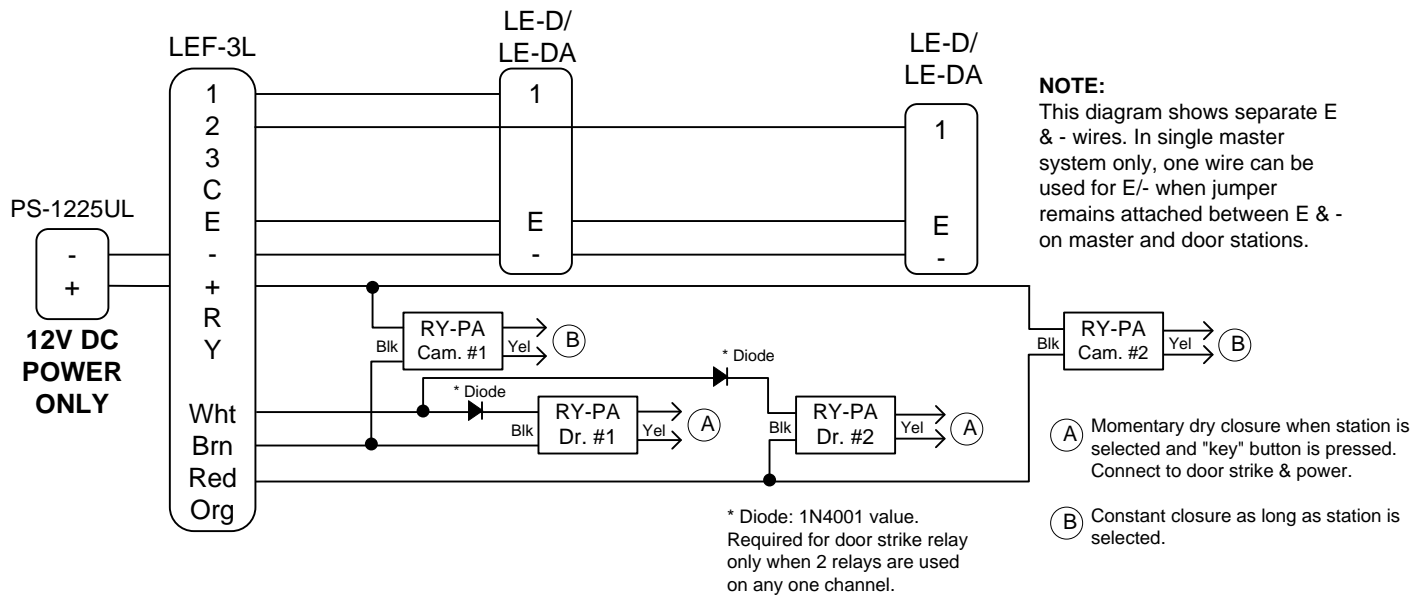

4 TROUBLESHOOTING GUIDE

ENTRY #	PROBLEM	POSSIBLE CAUSE	SOLUTION
1	Door station does not call in (no call tone or LED light).	Missing jumpers	Are there 2 or 3 conductors run to the door station? If 2 wires, jumper must remain attached between E and - at both the door station and the master station. Replace jumper. In a multi-master system, the E/- jumper should be removed and 3 wires should be connected.
2	Door station does not call in (no call tone or LED light) -- 3-wire connection.	Missing connection of - terminal.	If communication works, check connection between - terminal of door station and master. Test call-in at master station by touching a jumper wire between # and - terminal of master. If this rings the tone and lights the light, the - wire from the door station is not connected properly.
3	Door station does not call in (no call tone or LED light) -- 3-wire connection.	Mis-wiring of 1 and E terminals.	Check that the 1 and E wire are not reversed. If they are, communication will work but call-in will not.
4	No communication to door station.	Mis-wiring of E terminal.	Communication is between the 1 and E terminal of the door station to a # and E terminal of the master station. If call-in works, check the E wire for continuity. Check the 1 and - wires at the sub to ensure that they are not reversed.
5	No master-to-master communication.	C terminals mis-wired between masters.	Communication between masters is carried on the # wire of the calling master to the C terminal of the receiving master. Verify that the C terminal of the master that is being called is actually wired to the # terminal that is being selected on the calling master.
6	LEF master has no communication or tone, but LED lights work.	Wrong power supply is being used.	The LED lights will operate with a power source from 6VDC - 24VDC. The amplifier in the LEF unit will only work when the system is supplied 12VDC. Proper power supply is the PS-1225UL.
7	Feedback when the volume control is turned up over halfway.	E/- jumpers attached in a multi-master system.	Remove E/- jumpers on masters and door stations in the system, provided there are 3 wires to the sub(s). If the sub only has 2 wires in a multi-master system, the jumper must remain in place for the door call-in to work. In this case, the side effect is the feedback problem when the audio volume is turned up. The only alternative is to run the proper wire to the door station(s) and remove all of the jumpers.
8	New installation has AC buzz, noise, or hum in system.	Too close to AC and/or incorrect wire was used.	If the units are too close to an AC source such as AC wiring or dimmer switches, move the intercom at least one stud space away from the AC source. Other precautions include using shielded cable. If shielded wire was used and there is still AC noise, tie all the shields together and ground to an earth ground or negative on the power supply. If more than one jacketed cable was used between masters, make sure the # terminals, C terminal, and the E terminals are all in the same jacketed cable. If multiple cables were used, include an E wire in each cable that carries a station number wire in it.
9	Door release does not work.	Miswire or lack of RY-PA relays.	Check the WHITE wire coming out of the PC board for voltage. When depressing the key button, 12VDC is present across WHT and negative, which activates the relay. Ensure that the black wires of the RY-PA are connected to WHT and either the BRN, RED, or ORG wire for selective door release (which provides selective ground when the corresponding channel is selected).
10	No call tone between masters. No Privacy feature on LEF-3L.	Features not available	The LEF-3L unit does not have the PRIVACY feature or the ability to send a call tone to another master station (as with the standard LEF-3). This function is removed to allow the switch to be used for door release instead of privacy.
11	Can't release the door from the 2nd (additional masters)	Wiring not connected properly.	If door release works from the first master but not another(s), verify that selective door release wires are connected between masters. (WHT, BRN, RED, ORG). RY-PA's are only required at one master.
12	External Signaling device doesn't activate	RY-AC mis-wired	Make sure that the WHITE wire of the RY-AC is connected to the # terminal that is to be activating the relay, and that RED and BLK are connected to + and -, respectively.

5 MODIFICATIONS

CONVERTING THE RY-PA CONTACT OUTPUT TO NORMALLY CLOSED

Magnetic locks require Normally Closed (N/C) contacts, keeping power applied to the magnet to keep the door locked, and breaking power to release the door. These instructions explain how to change the RY-PA relay output from Normally Open (N/O) to Normally Closed.

Bottom view of relay module (inside plastic case) as it comes from the factory. (Normally Open)

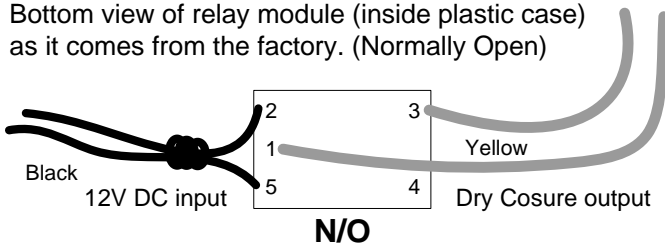

To change to NORMALLY CLOSED contact, unsolder the wire from pin 3 and resolder onto pin 4, as shown below.

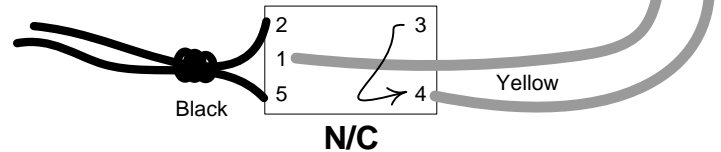

6 OPERATIONS & SPECIFICATIONS

OPERATION:

1. Pressing the call button at the door station will activate a tone, plus light the red channel LED indicator at the master. The tone will be momentary, and the light will remain activated for approximately 20 seconds.
2. The person at the master station answers the call by pressing the selector button with the lit LED. If the LED has already gone out, the call can still be answered by pressing the selector button.
3. Communication at the master station is "press-to-talk, release-to-listen". Communication at the door station is hands free.
4. If the "Camera Call-up" feature is included, the associated relay will provide a maintained closure as long as the station is selected at the master.
5. With communication established to a door station, pressing the door release button (marked with key symbol, left of TALK button) will activate the door release mechanism at the corresponding door. The door release button will be non-functional if a station button is not pressed.
6. When the conversation is completed, the OFF button must be pressed to disengage the call.

NOTE:

The LEF-3L does not have the "privacy feature", and also cannot send a call tone to another master or remote station in the system.

SPECIFICATIONS:

Power Source:	12V DC at master. Use PS-1225UL. Do not use AC power. Damage to the unit will result.
Communication Output:	800mW @ 20 ohms (receive); 500mW @ 20 ohms (transmit)
Communication:	Push-to-talk, release-to-listen at master station. Hands free at sub station.
Calling:	Master to sub: By voice Sub to master: Call tone and LED
Wiring:	2 common plus 1 individual per sub, looped; or 3 conductors homerun from each sub. 2 conductors homerun from each sub in a single-master system only. Use Aiphone #822202 or #821802 (2 cond., 22 or 18AWG), or #822203 (3 cond. 22AWG) 12 conductors between master stations. Use Aiphone #822212. Shielded cable is strongly recommended.
Wiring Distance:	650' with 22AWG; 1,600' with 18AWG.
Dimensions (HxWxD):	7-1/16" x 5-5/8" x 2-3/16"
RY-PA Contact Rating:	1A, 110V AC or 24V DC