

IP INTERCOM EXCHANGE

AN-8000EX

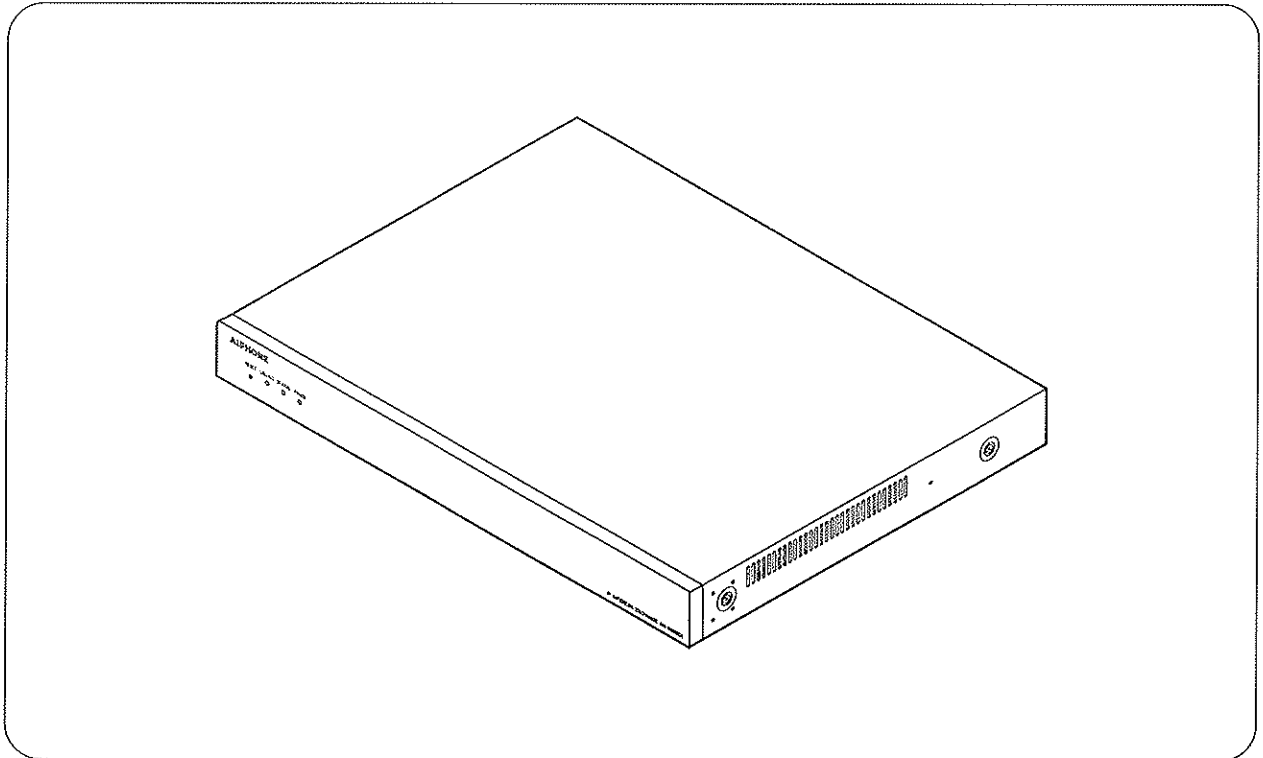

Thank you for purchasing AIPHONE's IP Intercom Exchange.
Please carefully follow the instructions in this manual to ensure long, trouble-free use of your equipment.

TABLE OF CONTENTS

1. SAFETY PRECAUTIONS	3
2. GENERAL DESCRIPTION	4
3. FEATURES	4
4. SPECIFICATIONS	4
5. SYSTEM CONFIGURATION EXAMPLE	5
6. NOMENCLATURE AND FUNCTIONS	
Front	6
Rear	6
7. INSTALLATION	
7.1. Rack Mounting	
7.1.1. Setting space	7
7.1.2. Caution when installing the unit	7
7.1.3. Mounting on the rack	8
7.2. Desk-Top Installation	8
7.3. Wall Mounting	9
8. WIRING	
8.1. Connection Diagram	10
8.2. Type of Cable	12
8.3. Relations Between Core Diameter of Cable and Maximum Cable Length	12
8.4. Connector Connection	
8.4.1. Mini-clamp connector connection	13
8.4.2. Removable terminal plug connection	14
8.5. E-7000TB Terminal Board Wiring	15
9. ACCESSORIES	16

1. SAFETY PRECAUTIONS

- Before installation or use, be sure to carefully read all the instructions in this section for correct and safe operation.
- Be sure to follow all the precautionary instructions in this section, which contain important warnings and/or cautions regarding safety.
- After reading, keep this manual handy for future reference.

Safety Symbol and Message Conventions

Safety symbols and messages described below are used in this manual to prevent bodily injury and property damage which could result from mishandling. Before operating your product, read this manual first and understand the safety symbols and messages so you are thoroughly aware of the potential safety hazards.



WARNING

Indicates a potentially hazardous situation which, if mishandled, could result in death or serious personal injury.



CAUTION

Indicates a potentially hazardous situation which, if mishandled, could result in moderate or minor personal injury, and/or property damage.



WARNING

When Installing the Unit

- Do not expose the unit to rain or an environment where it may be splashed by water or other liquids, as doing so may result in fire or electric shock.
- Use the unit only with the voltage specified on the unit. Using a voltage higher than that which is specified may result in fire or electric shock.
- Do not cut, kink, otherwise damage nor modify the power supply cord. In addition, avoid using the power cord in close proximity to heaters, and never place heavy objects -- including the unit itself -- on the power cord, as doing so may result in fire or electric shock.
- Avoid installing or mounting the unit in unstable locations, such as on a rickety table or a slanted surface. Doing so may result in the unit falling down and causing personal injury and/or property damage.
- Install the unit only in a location that can structurally support the weight of the unit and the mounting bracket. Doing otherwise may result in the unit falling down and causing personal injury and/or property damage.

When the Unit is in Use

- Should the following irregularity be found during use, immediately switch off the power, disconnect the power supply plug from the AC outlet and contact your nearest AIPHONE sales office. Make no further attempt to operate the unit in this condition as this may cause fire or electric shock.

- If you detect smoke or a strange smell coming from the unit
- If water or any metallic object gets into the unit
- If the power supply cord is damaged (exposure of the core, disconnection, etc.)
- If it is malfunctioning (no tone sounds.)
- To prevent a fire or electric shock, never open nor remove the unit case as there are high voltage components inside the unit. Refer all servicing to your nearest AIPHONE sales office.
- Do not insert nor drop metallic objects or flammable materials in the ventilation slots of the unit's cover, as this may result in fire or electric shock.
- Do not touch a plug during thunder and lightning, as this may result in electric shock.



CAUTION

When Installing the Unit

- Never plug in nor remove the power supply plug with wet hands, as doing so may cause electric shock.
- When unplugging the power supply cord, be sure to grasp the power supply plug; never pull on the cord itself. Operating the unit with a damaged power supply cord may cause a fire or electric shock.
- Do not block the fan exhaust vent on the unit's rear. Doing so may cause heat to build up inside the unit and result in fire.

- Be sure to follow the instructions below when rack-mounting the unit. Failure to do so may cause a fire or personal injury.
 - Install the equipment rack on a stable, hard floor. Fix it with anchor bolts or take other arrangements to prevent it from falling down.
 - To mount the unit on the equipment rack CR-273 or CR-413, use the rack mounting hardware supplied with the unit.
 - When connecting the unit's power cord to an AC outlet, use the AC outlet with current capacity allowable to the unit.

When the Unit is in Use

- Do not place heavy objects on the unit as this may cause it to fall or break which may result in personal injury and/or property damage. In addition, the object itself may fall off and cause injury and/or damage.
- Do not stand or sit on, nor hang down from the unit as this may cause it to fall down or drop, resulting in personal injury and/or property damage.

2. GENERAL DESCRIPTION

AIPHONE's AN-8000EX is an exchange used for the AN-8000 Series Network Intercom System (IP network compatible intercom) employing packet audio technology^{*1}. By connecting IP intercom exchanges (which permit connection of up to 16 stations per exchange) to a network (LAN or WAN), an optimal system for in-house or wide area information communications, such as duplex conversations between stations and paging broadcasts, can be constructed. Since up to 80 exchanges can be combined, systems of up to a total of 1,280 stations can be realized. The system's "echo cancellation"^{*2} feature makes hands-free duplex conversation possible (conversations made without using a handset at both parties) between stations.

*1 Technology related to audio transmission over a network.

*2 A circuit that prevents acoustic feedback or echo generated when the voice output from the station's internal speaker enters the microphone.

Warning

This is a class A product. In a domestic environment this product may cause radio interference in which case the user may be required to take adequate measures.

3. FEATURES

- Exchanges can be distributed over a data communications network.
- Can be connected to an existing local area network (LAN) or wide-area network (WAN). The system can also be easily connected to fiber-optic networks without restrictions on operating distance.
- The dedicated software program enables centralized control with a personal computer.
- System maintenance (verifying operation log and Line supervision) can also be performed with a personal computer and Internet browser.

4. SPECIFICATIONS

Number of Exchanges

connectable to LAN: Maximum 80

Line Capacity: Maximum 1,280 (80 Exchanges x 16 stations per Exchange)

Speech Link Capacity

(Internal): 4 links

(External): Speech Link: maximum 8 links, Multicast paging Link: maximum 4 links, Unicast paging: 1 link (simultaneous access capacity)

Paging Zones Capacity: Maximum 160 (With 80 Exchanges)

Paging Zone: Maximum 79 (Multicast paging), Maximum 16 (Unicast paging)

System Settings: Personal computer setting using a dedicated software program (over LAN)

(Network Related)

Voice delay time: 80 or 320 ms, selectable

Usage bandwidth: Maximum 2.08 Mbps (one way) when 16 Unicast pagings are made

Maximum 130 kbps (two-way) per call

DISTRIBUTED BY: www.leedan.com info@leedan.com

5. SYSTEM CONFIGURATION EXAMPLE

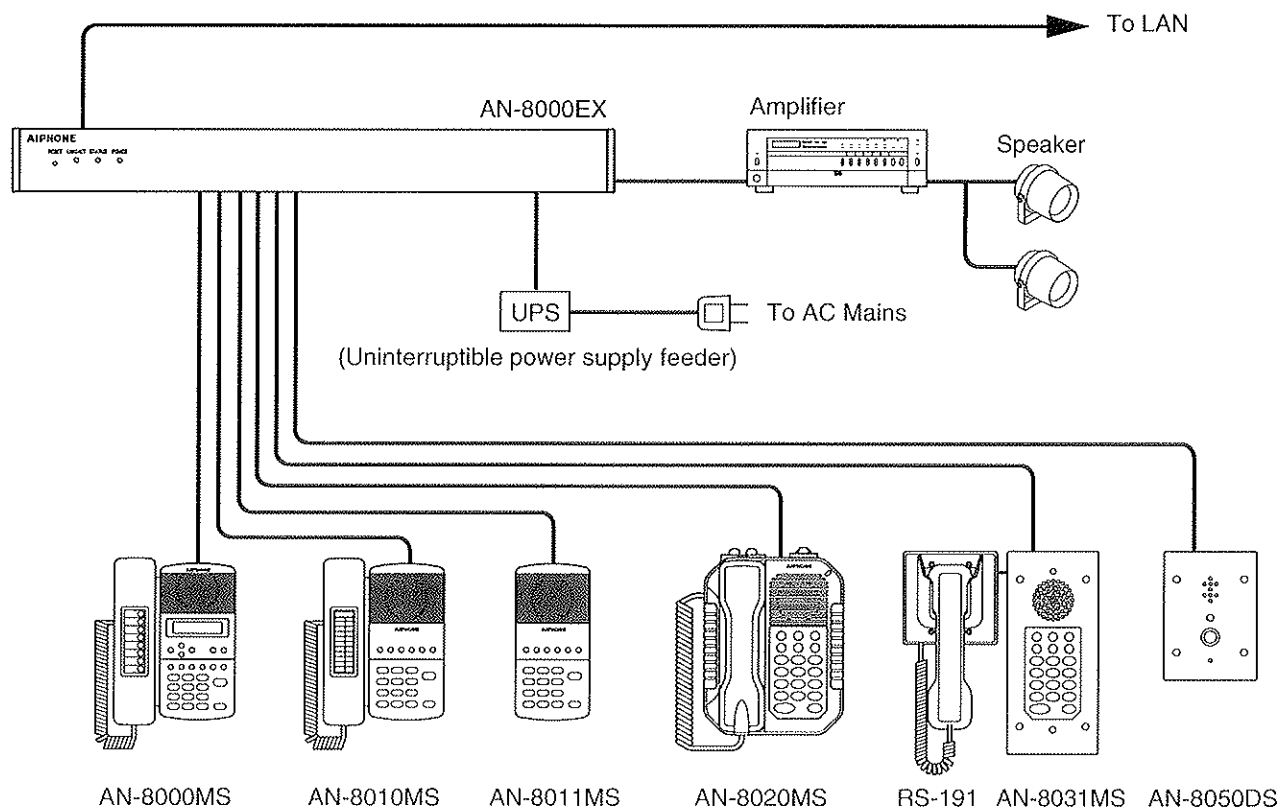

[Exchange]

AN-8000EX: IP Intercom Exchange

[Stations]

AN-8000MS: Multifunctional Master Station
 AN-8010MS: Standard Master Station
 AN-8011MS: Standard Hands-Free Master Station
 AN-8020MS: Industrial-Use Master Station
 AN-8031MS: Flush-Mount Master Station
 RS-191: Option Handset
 AN-8050DS: Door Station

[Others]

YC-280: Wall mounting bracket for the AN-8000MS/8010MS/8020MS
 YC-290: Wall mounting bracket for the AN-8011MS
 YC-241: Back box for the AN-8031MS
 YC-251: Wall-mount box for the AN-8031MS
 YC-150: Back box for the AN-8050DS
 YS-13A: Wall-mount box for the AN-8050DS
 E-7000TB: 40-Station Terminal Board
 CR-273: Equipment Rack
 CR-413: Equipment Rack

6. NOMENCLATURE AND FUNCTIONS

[Front]



1. Reset key [RESET]

Pressing this key reactivates the exchange.

2. LNK/ACT indicator [LNK/ACT] (Green)

Lights when connected to a network, and flashes while transmitting or receiving data.

3. Status indicator [STATUS] (Red)

Continuously lights while data is written to an internal storage medium (FlashMemory), and flashes to indicate such exchange malfunctions as cooling fan failure.

4. Power indicator [POWER] (Green)

Lights when power is supplied to the exchange.

5. MAC address

This is the address* used by the exchange. Since the relationship of each exchange location to its MAC address is established when setting the network attributes, keep track of this relationship for later use.

* The inherent address assigned to each network component, expressed in 12-digit hexadecimal notation.

[Rear]

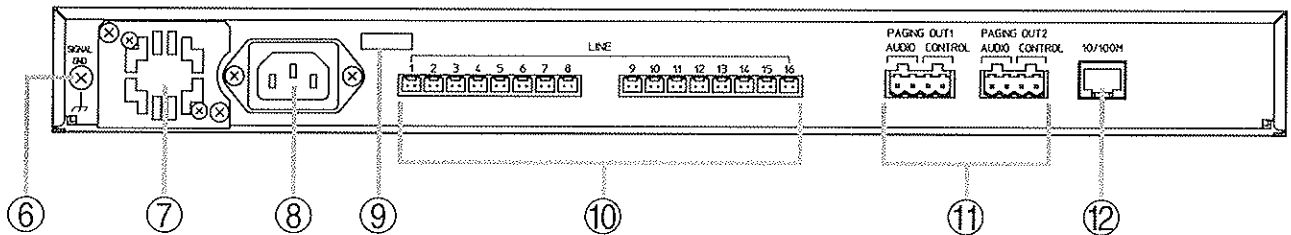

6. Functional earth terminal [SIGNAL GND]

Ground this terminal.

Note: This terminal is not a safety ground.

7. Cooling fan

⚠ CAUTION

Do not block the fan exhaust vent. Doing so may cause heat to build up inside the unit and result in fire.

8. AC inlet

Connects the supplied power cord.

Note

If there is a danger of lightning strikes, insert an appropriate surge arrester into the power line.

9. Cord clamp

Pass the power cord through this clamp to ensure that the plug cannot be pulled out when the unit is mounted to a wall. (Refer to p. 9)

10. Line connection terminal [LINE]

Connect the station to each terminal using a mini-clamp connector. (Refer to p. 13)

11. Paging output terminals

[PAGING OUT 1/2, AUDIO/CONTROL]

Includes audio outputs (0 dB*, 600 Ω, balanced) and contact outputs (no-voltage make, 24 V DC, 0.5 A MAX).

Connect using a removable terminal plug. (Refer to p. 14)

12. Network connection terminal [10/100M]

Connects a 10BASE-T- or 100BASE-TX-compatible network. (Ethernet RJ45 jack)

* 0 dB = 1 V

7. INSTALLATION

The exchange can be installed in any of three ways: (1) rack mounting, (2) wall mounting, and (3) desk-top installation.

7.1. Rack Mounting

- A) Elevated Operating Ambient - If installed in a closed or multi-unit rack assembly, the operating ambient temperature of the rack environment may be greater than room ambient. Therefore, consideration should be given to installing the equipment in an environment compatible with the maximum ambient temperature (T_{ma}) specified by the manufacturer.
- B) Reduced Air Flow - Installation of the equipment in a rack should be such that the amount of air flow required for safe operation of the equipment is not compromised.
- C) Mechanical Loading - Mounting of the equipment in the rack should be such that a hazardous condition is not achieved due to uneven mechanical loading.
- D) Circuit Overloading - Consideration should be given to the connection of the equipment to the supply circuit and the effect that overloading of the circuits might have on overcurrent protection and supply wiring. Appropriate consideration of equipment nameplate ratings should be used when addressing this concern.
- E) Reliable Earthing - Reliable earthing of rack-mounted equipment should be maintained. Particular attention should be given to supply connections other than direct connections to the branch circuit (e.g. use of power strips)."

The Exchange can be mounted on the CR-273 or CR-413 or standard EIA 19" Equipment rack. These racks, when fully equipped with exchanges, can provide the following capacity of stations: 128 stations for one CR-273, 192 stations for one CR-413, and 1,280 stations for seven CR-413s. For the CR-273 and CR-413 Equipment rack assembly or BU-412 Blower unit installation, read the installation manual supplied with the rack.

Note

When installing the blower units, terminal boards, and exchanges, lay the equipment rack down face-up to do installation work safely. Since the blower unit is installed from the inside of the rack, be sure to install it first, before mounting the other components.

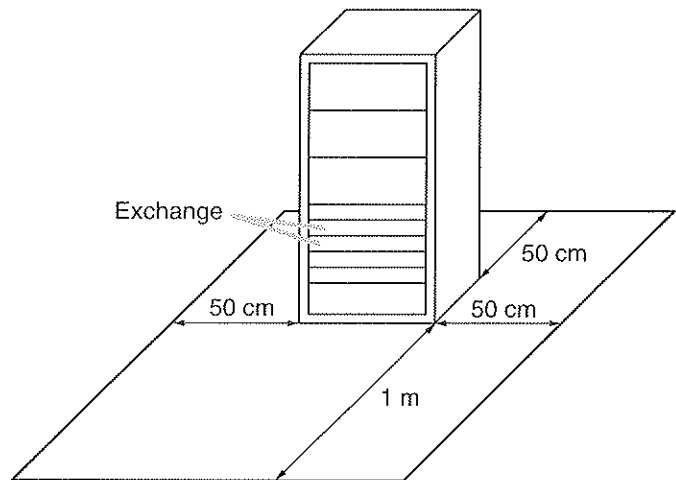

7.1.1. Setting space

For maintenance works, allow much space between the wall and Equipment rack.

7.1.2. Caution when installing the unit



CAUTION

Do not block the fan exhaust vent. Doing so may cause heat to build up inside the unit and result in fire.

Do not stack up 3 Exchanges or more. If 2 or more Exchanges are mounted in the Equipment rack, be sure to mount the perforated panel of 1 U size (PF-013B) or more above and below every 2 Exchanges.

Using the supplied rack mounting screws, install the terminal board in a location that facilitates wiring and maintenance work, taking into consideration the direction of cable entry into the rack.

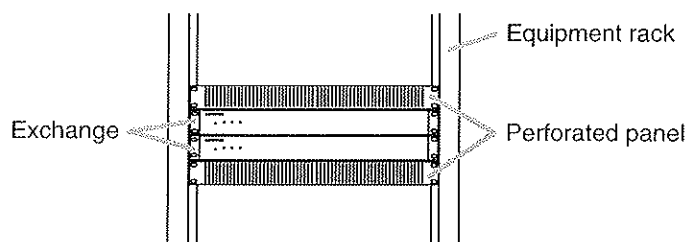

DISTRIBUTED BY: www.leedan.com info@leedan.com

7.1.3. Mounting on the rack

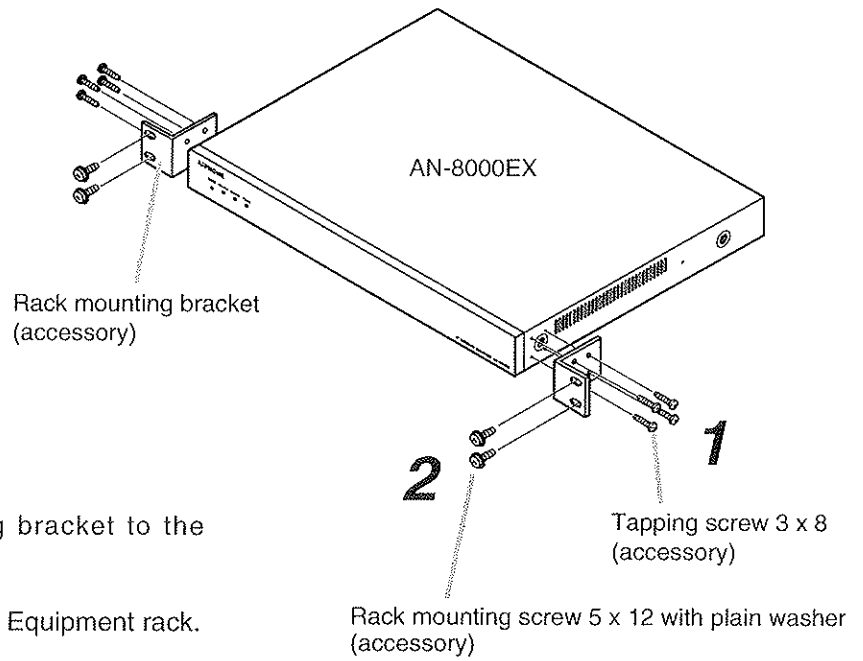

7.2. Desk-Top Installation

When installing the Exchange on a desk, secure the supplied plastic feet to bottom surface of the Exchange using the supplied machine screws.

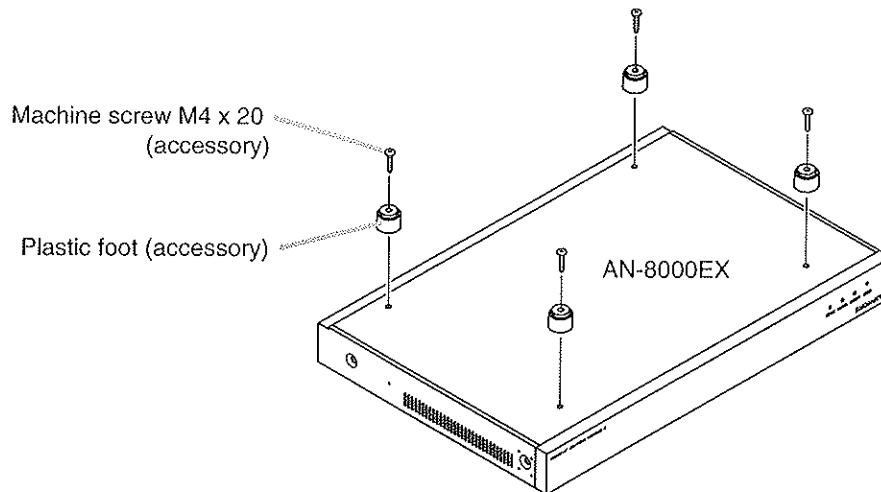

7.3. Wall Mounting

Step 1. Install the supplied wall-mounting bracket to the Exchange using each 2 supplied screws and removed screws from the case.

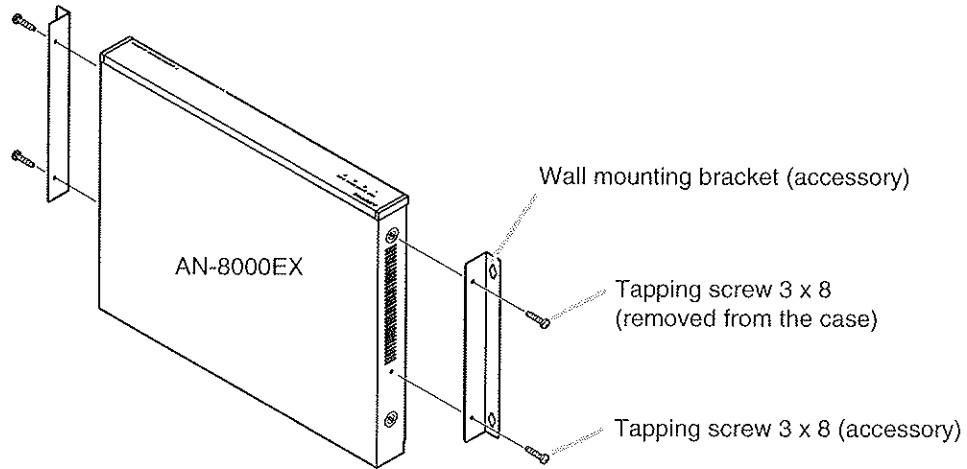

Step 2. Mount the Exchange on the wall.

Notes

- Use appropriate screws for the construction of wall.
- Wood screws 3.5 x 20 are supplied with the AN-8000EX.
- The socket-outlet shall be installed near the equipment and shall be easily accessible.

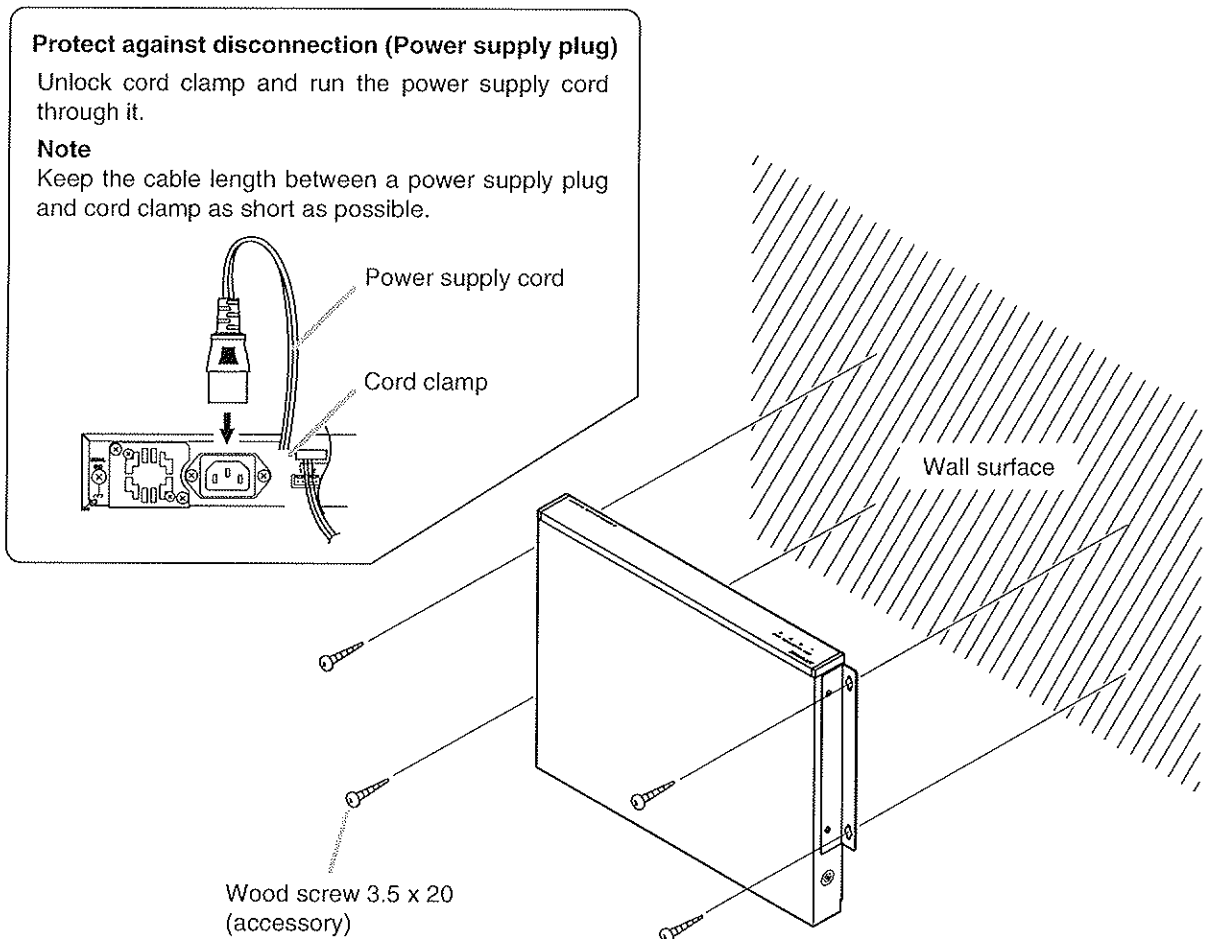

8. WIRING

8.1. Connection Diagram

AN-8000EX Exchange

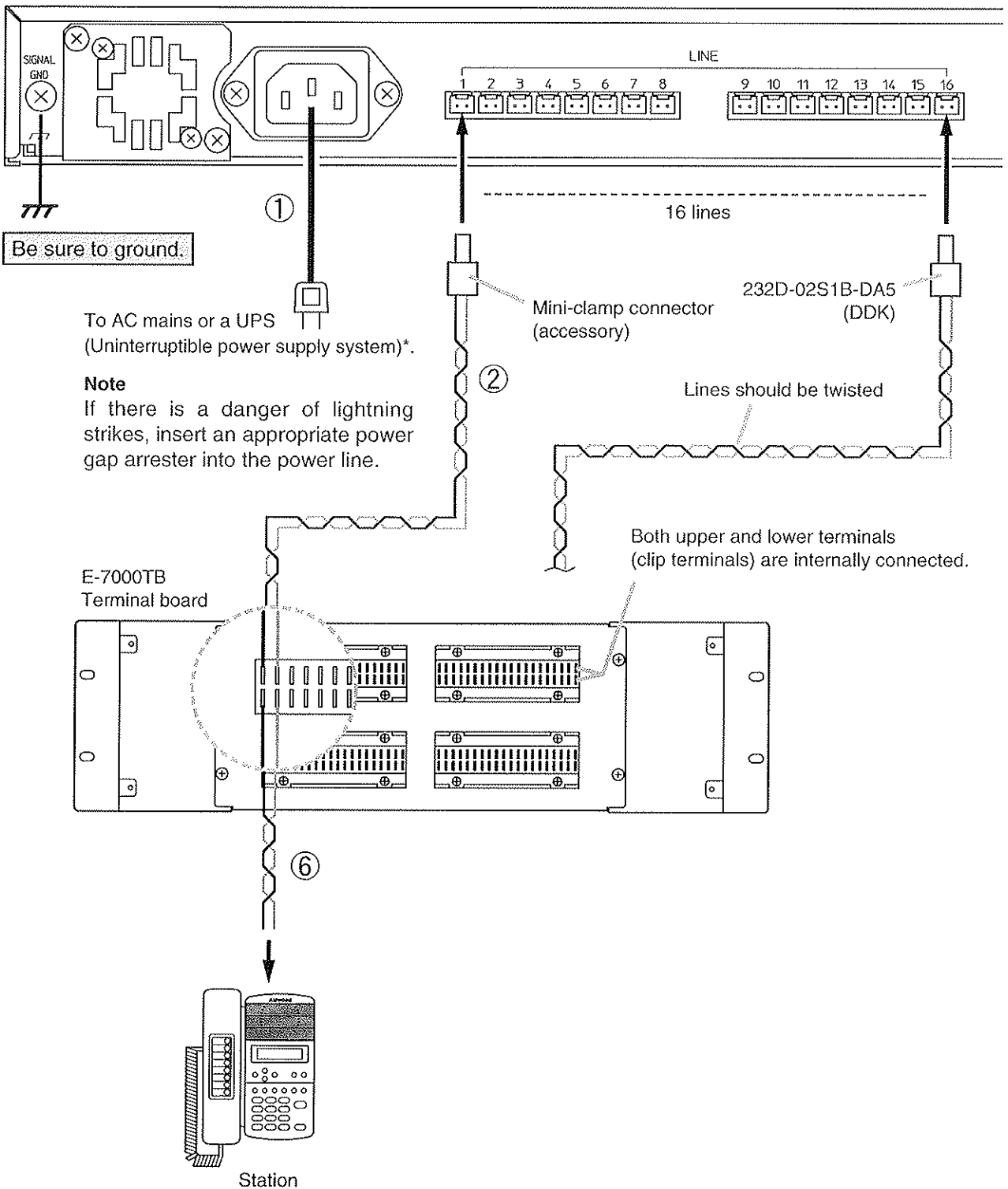

* Select an appropriate UPS taking into consideration the total power consumption of all system components and the required backup time, and also the requirement that the UPS should employ the on-line power system.

Reference

Exchange: Maximum 50 W.

8-Port 10M/100M Switching Hub: 10W (Differs depending on products.)

DISTRIBUTED BY: www.leedan.com info@leedan.com

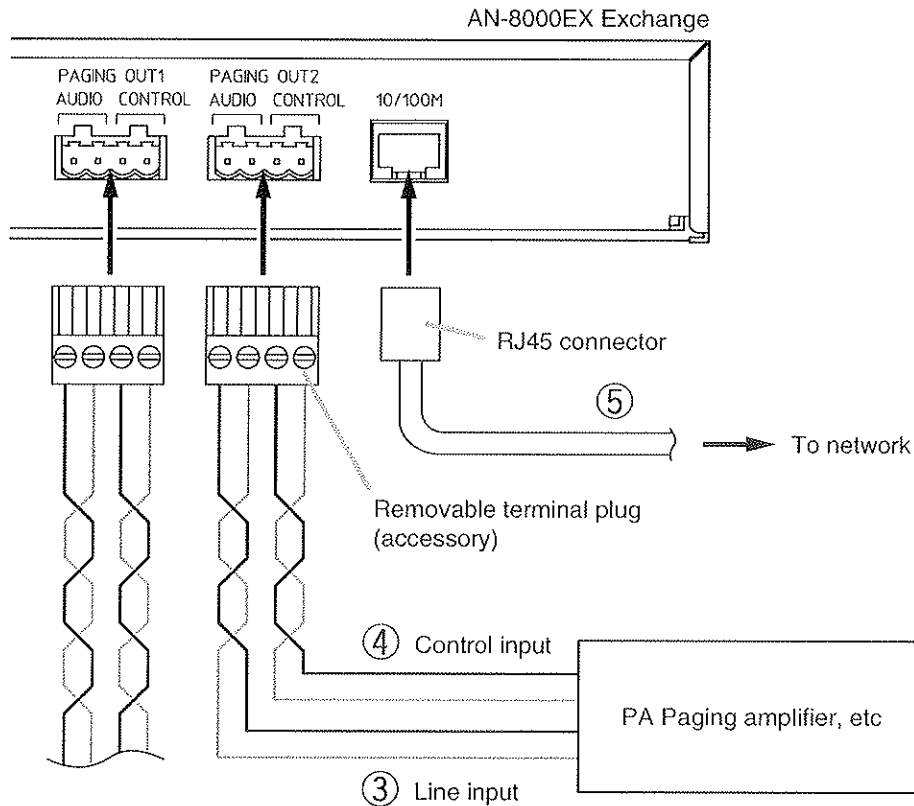

[General description of connection]

For cables, refer to p. 12.

1. Power supply connection

Connect the supplied power supply cord to AC Mains or a UPS (Uninterruptible power supply feeder).

About power supply cord handling

The supplied power supply cord is designed for exclusive use with the AN-8000EX. Use the supplied power supply cord only with the Exchange.

2. Line terminal connection

The line terminals have no polarity. (Refer to p. 13, Connector connection.)

3. Paging audio output terminal connection

Paging audio output terminals have no polarity. (Refer to p. 14, Removable terminal plug connection.)

[Specification of paging audio output]

0 dB*, 600 Ω, balanced

4. Paging contact output terminal connection

Paging contact output terminals have no polarity. (Refer to p. 14, Removable terminal plug connection.)

[Specification of paging contact output]

No voltage make contact output
Withstand voltage: Max. 24 V DC
Control current: Max. 0.5 A

5. Network connection

Can be connected to a network of 10BASE-T/100BASE-TX in auto-sensing. Use a UTP category 5 straight-through cable for this connection.

6. Station connection

The connection method differs depending on types of stations. For details, refer to the instruction manual supplied with each station.

* 0 dB = 1 V

8.2. Type of Cable

The types of cables are to be determined according to the following conditions.

- Twisted pair wires (such as those used for electronic push-button telephone) are to be used for wiring between the Exchange and the stations in principle.
- UTP category 5 Straight through cables with RJ45 connector are to be used for wiring the equipments connected to IP network.
- The number of cables pairs laid should be determined considering the possibility of future expansion of the system.
- Outdoor wires should be used where wiring passes through inaccessible areas such as ceilings or under floors where the maintenance is not performed. Indoor wires may also be used, however, in case where there is no risk of deterioration due to exposure to heat, etc.

Note

Specifications related to each junction are as follows.

Mini-clamp connector (AN-8000EX line terminal)

Conductor diameter: \varnothing 0.4 – 0.65 mm (AWG22 – 26), Solid wire

Outside diameter: \varnothing 1.05 mm or below

Clip terminal (E-7000TB)

Conductor diameter: \varnothing 0.4 – 0.8 mm (AWG20 – 26), Solid wire

Outside diameter: \varnothing 1.5 mm or below

Removable terminal plug (AN-8000EX Paging output)

Conductor diameter: \varnothing 0.5 – 2 mm (AWG12 – 24), Solid wire/Stranded wire

8.3. Relations Between Core Diameter of Cable and Maximum Cable Length

Refer to the following table as guidelines when designing the distance between the Exchange and stations so that loop resistance value becomes 170 Ω or less.

Conductor diameter (mm)	Loop resistance (Ω /km)	Maximum cable length between the Exchange and station. (Assuming that the loop resistance is 170 Ω)
\varnothing 0.4	295	570 m
\varnothing 0.5	187	900 m
\varnothing 0.65	113	1.5 km
\varnothing 0.9	58	2.9 km

8.4. Connector Connection

Mini-clamp connectors for line terminals and detachable terminal plugs for paging output terminal are supplied with the AN-8000EX Exchange.

Perform each connector connection as follows.

8.4.1. Mini-clamp connector connection

Connect the mini-clamp connector supplied with the AN-8000EX to a cable using a commercially available tool (pliers).

Step 1. Cut off two-cable ends in equal length, and insert them securely to a cover section (transparent side) of the mini-clamp connector.

Note

Insert the cable without stripping the cable jacket.
For cables, refer to p. 12, Type of Cable.

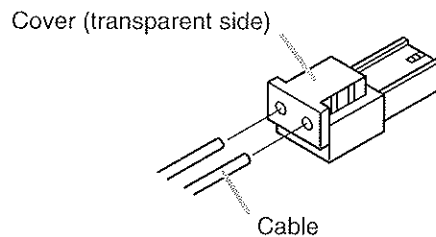

Step 2. With a pair of pliers, lightly pinch the mini-clamp cover and, after ensuring that the cable is securely inserted, firmly squeeze on the cover.

Note

Squeeze on the mini-clamp cover until it is correctly locked.

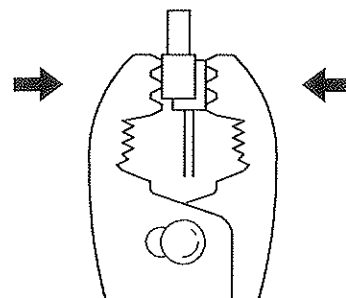

Step 3. Insert the wired connector (plug) into the exchange's connector (socket) until it locks into place.

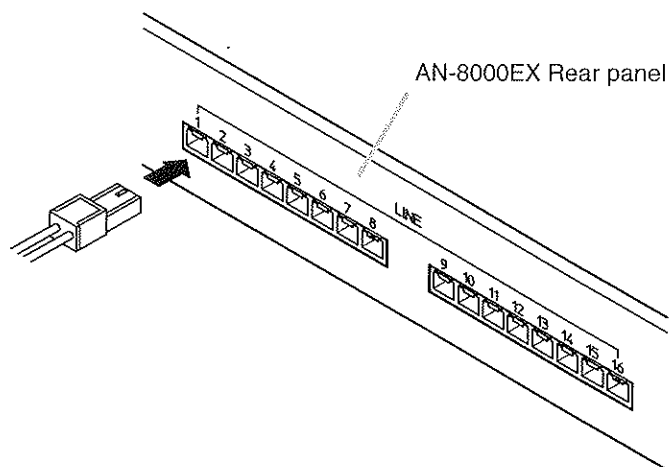

8.4.2. Removable terminal plug connection

Step 1. Strip a cable jacket of approx. 7 mm to expose inner cable.

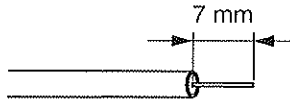

For cables, refer to p. 12, Type of Cable.

Note

Do not solder plate on exposed inner cables when using a stranded wire.

Step 2. Loosen the terminal screws and insert the cables.

Step 3. Tighten the terminal screws securely.

Notes

- Tug lightly on the cable to be sure that it does not pull free. If the cable pulls free, loosen the terminal screw again and reconnect from **Step 2**.
- Use the screwdriver appropriate to the screws tightened into the terminal plug.

Step 4. Insert the wired terminal plug into the terminal block of the Exchange.

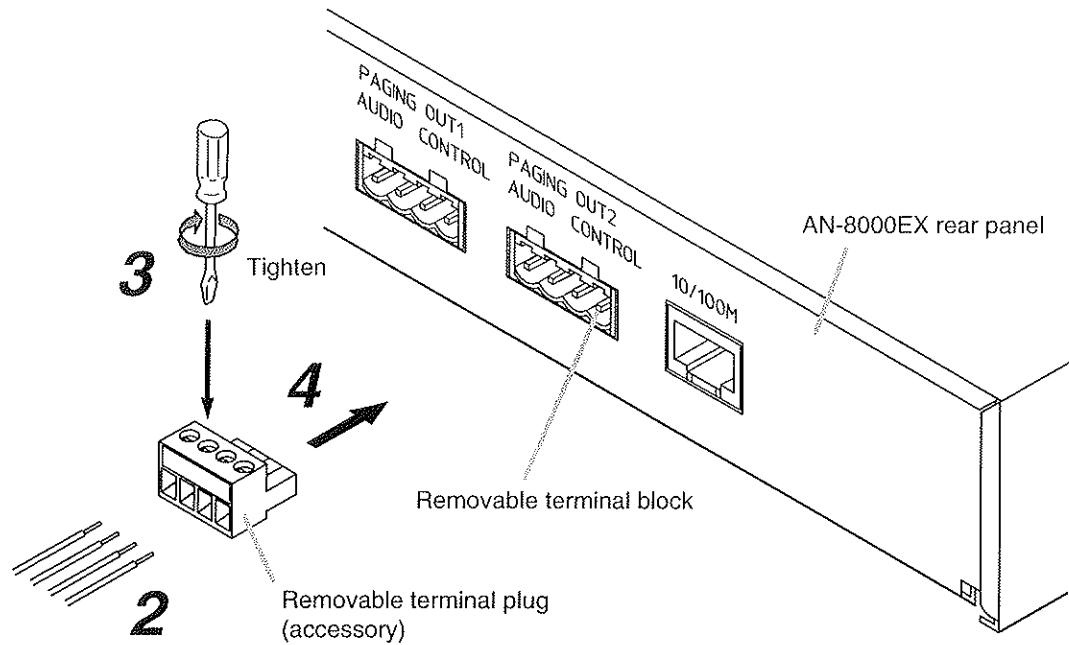

8.5. E-7000TB Terminal Board Wiring

For cable connection to the E-7000TB Terminal Board use the optional YC-105, clipping tool. Hook the end of the cable onto the terminal and, with the cable end in hand, press the YC-105 Dedicated Tool down onto the terminal from above. Pressing down the YC-105 tool cuts off the excess cable end, securing the connection.

For cables, refer to p. 12, Type of Cable.

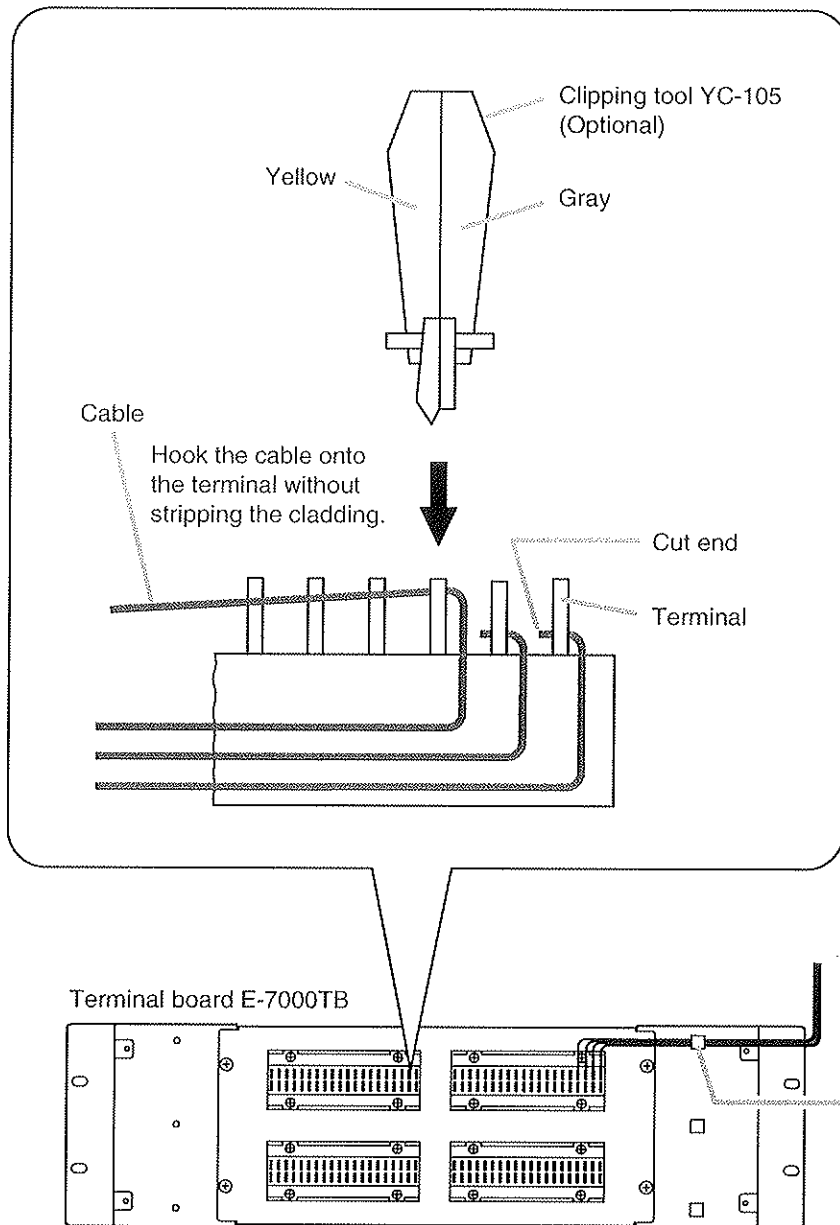

9. ACCESSORIES

Power supply cord (2 m)	1	Rack mounting bracket	2
CD*	1	Tapping screw 3 x 8	8
Removable terminal plug (4P)	2	Rack mounting screw 5 x 12	
Mini-clamp connector (2P)	20	with plain washer	4
Plastic foot	4	Wall mounting bracket	2
Machine screw M4 x 20	4	Wood screw 3.5 x 20	4

* Contains the AN-8000 setting software program and the AN-8000 series instruction manual. The Setup Launcher is automatically started when the supplied CD-ROM is inserted into the PC's drive.

Note

If your PC's CD drive is not compatible with the AutoRun function, the setup guide is not automatically started even when the CD is inserted. Use either "Explorer" or "My Computer" to execute the following files, or use [Start → Run] in the Task Bar and enter the following command.

<Drive where CD is placed> \index.html

For example, when placing the CD in the "d" drive, → d:\index.html

Version update information

- Please contact to the AIPHONE sales office to obtain the up-to-date version for firmware, software and the instruction manuals.
- The software version number can be confirmed using the Help menu.
- The current firmware version can be confirmed on the system management screen displayed when the browser establishes the connection to the Exchange.
- The instruction manual version number can be confirmed by checking the preparation date (month and year) shown at the lower right corner of the last page.
Example: Prepared in November 2004: 200411