

# Conventional Fire Alarms

## Smoke Detectors

### SC Series



The SC Series ionization smoke detectors have a dual chamber design, so they automatically compensate for environmental changes such as atmospheric pressure, humidity and ambient temperature.

A red LED indicator situated on the detector molding provides clear indication when the unit is in alarm.

SC10U-3 detectors plug into the CSBU-1 base unit by a simple twist and lock action. In order to prevent unauthorized removal, a site selectable option is provided to lock the detector into its base. Once applied, the unit can only be removed by means of a special tool.

All SC10U-3 detectors are monitored for detector removal. When a detector (or detectors) is removed from its base, a fault condition is detected.

### Features and Specifications

- LED alarm indication
- Sensitivity test feature with use of C-PST test tool
- Tamper resistant with site selectable lock
- White molded high impact fire retardant plastic
- Advanced dual chamber
- Surface mount technology
- Operating temperature range: 32°F to 100°F (0°C to 37.8°C)

### Ordering Information

Description	Cat. No.	Operating Voltage	Current		Sensitivity Range	Terminal Sizes
			Standby	Alarm		
Smoke Detector with Base	<b>SC10U-3B</b>	14V - 30V DC	0.00005 A	0.100 A max.	0.65-1.05% obs/ft.	12-18 AWG
Smoke Detector	<b>SC10U-3</b>	14V - 30V DC	0.00005 A	0.100 A max.	0.65-1.05% obs/ft.	12-18 AWG
Detector Base (Surface Mount)	<b>CSBU-1</b>	—	—	—	—	—
Detector Base with Resistor	<b>CSBU-3<sup>1</sup></b>	—	—	—	—	—

<sup>1</sup>For use with non-current limited circuits.

### Accessories

Description	Cat. No.
Test Picker Tool for Sensitivity Reading and Removal	<b>C-PST</b>



Distributed By: Lee Dan Communications, Inc.  
[www.leadan.com](http://www.leadan.com) [info@leadan.com](mailto:info@leadan.com) Toll-Free 1-800-231-1414

# Conventional Fire Alarms

## Smoke Detectors

### SC Series

#### Weights and Dimensions

Cat. No.	Approx. Shipping Weight (lb.)
SC10U-3B	0.23
SC10U-3	0.23
CSBU-3	0.20
CSBU-1	0.20
C-PST	5.50

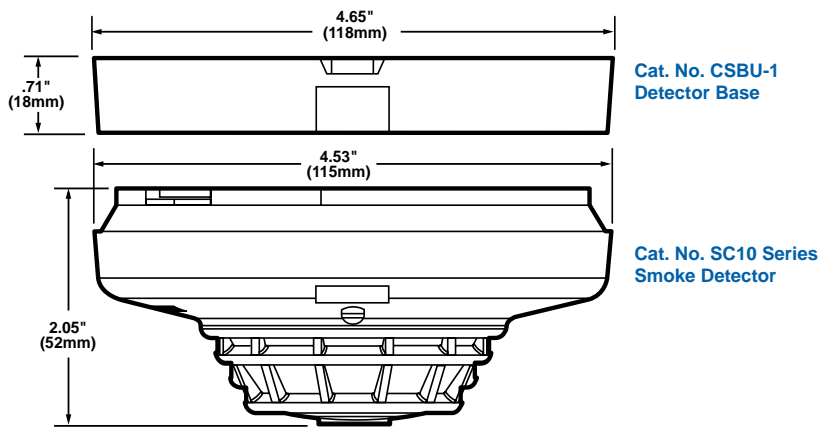

Distributed By: Lee Dan Communications, Inc.  
[www.leedan.com](http://www.leedan.com) [info@leedan.com](mailto:info@leedan.com) Toll-Free 1-800-231-1414