



AdaptaHorn® Panel Mount Vibrating Horn

NEMA Type 4X

870P & 871P Series

FEATURES

- > PLC compatible models
- > Corrosion resistant finish
- > Volume adjustable
- > Completely assembled
- > NEMA Type 4X rated

AGENCY APPROVALS

- > UL Listed

SPECIFICATIONS

- > Operating range: -20% to +10% of nominal voltage
- > Heavy duty die-cast housing
- > 18" (457mm) wire with molex connector

870P AC Series

- > Adjustable output: 78 to 103 dB
- > 400 hour rating at 50% duty cycle

871P DC Series

- > Adjustable output: 78 to 101 dB
- > 200 hour rating

www.leedan.com info@leedan.com Toll-Free: 1-800-231-1414

The Edwards 870P AC & 871P DC Series are low-current, high decibel panel mount vibrating horns for heavy-duty use. Supplied complete with gasket and UL listed to NEMA 4X enclosure requirements.

Designed for semi-flush panel mounting, using supplied mounting template, or installation on a 4" (102mm) square box. For NEMA 4X installation, mount to a NEMA 4X enclosure having a flat, smooth surface using supplied 1/8" (3mm) gasket in accordance with the installation instructions provided with the unit.

Applications include use in panel boards and switchboards wherever a distinctive, urgent signal is required for timing, general alarm & warning.

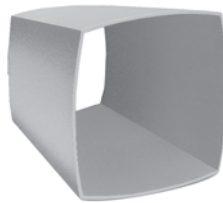

872-PO Plastic Projector AdaptaHorn Accessory

Plastic projector snaps onto any AdaptaHorn. Available as separate item.

TECHNICAL INFORMATION

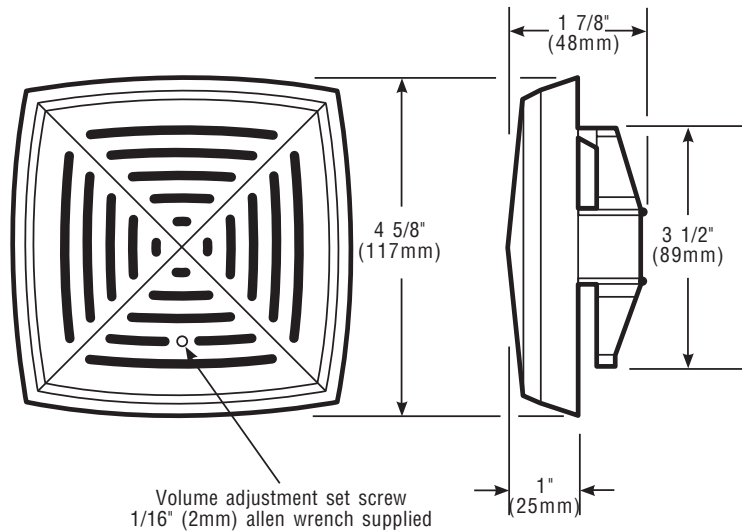

Cat. No.	Volts	Amps	V A	DC coil Res. (Ohms)	dB at 10 Ft.
870P-E5	12V AC	1.25	15.0	1.5	103
870P-G5	24V AC	0.63	15.1	5.2	
870P-N5	120V AC	0.13	15.6	150	
870P-R5	240V AC	0.07	16.8	580	
871P-C1	6V DC	0.7	4.2	1.4	101
871P-E1	12V DC	0.27	3.2	6	
871P-G1	24V DC	0.16	3.8	24	
871P-J1	32V DC	0.11	3.52	40	
871P-P1	125V DC	0.025	3.1	600	
871P-S1	250V DC	0.014	3.5	2640	

PLC COMPATIBILITY - SIGNAL INPUT LOAD CHARACTERISTICS*

Cat. No.	Operating voltage Volts	Max. off state leakage current mA	Continuous on current mA	Surge (inrush/duration) Amps/milliseconds
870P-N5	120V AC	25	120	1.02/.000026
871P-G1	24V DC	25	150	1.7/.000042

*This device is PLC compatible and may be operated by PLCs with output characteristics that match the input load requirements of this signal.

Electromechanical devices can produce transient spikes and should only be used on PLC output cards that have inherent transient spike suppression. Consult the PLC manufacturer prior to connecting 24V DC electromechanical devices to PLCs.

Distributed By: LEE DAN COMMUNICATIONS, INC.
www.leedan.com info@leedan.com Toll-Free: 1-800-231-1414

